

Krzysztof Wach (krzysztof.wach@mech.pk.edu.pl)

Institute of Automobiles and Internal Combustion Engines, Faculty of Mechanical Engineering, Cracow University of Technology

Robert Kupiec

Laboratory of Coordinate Metrology, Faculty of Mechanical Engineering, Cracow University of Technology

DETERMINATION OF INITIAL CONFIGURATION OF MECHANISM  
OF AN INSTRUMENT FOR MEASURING THE TRANSLATION AND ROTATION  
OF A STEERED WHEEL

---

WYZNACZANIE KONFIGURACJI POZATKOWEJ MECHANIZMU  
PRZYRZĄDU DO POMIARU TRANSLACJI I ROTACJI KOŁA KIEROWANEGO

**Abstract**

This paper concerns the determination of the initial configuration of a mechanism of a prototypical instrument for measuring the translation and rotation of a steered wheel. It covers the determination of coordinates of characteristic points of the mechanism. They were measured using a ROMER measuring arm. In the paper the methodology of measurements is discussed, and in addition the results obtained are presented and their analysis conducted.

**Keywords:** car, steered wheel, prototypical measuring instrument, coordinate measurements, ROMER measuring arm

**Streszczenie**

Praca dotyczy wyznaczania konfiguracji początkowej mechanizmu prototypowego przyrządu do pomiaru translacji i rotacji koła kierowanego. Polegało to na wyznaczeniu współrzędnych charakterystycznych punktów jego mechanizmu. Pomiary przeprowadzono z wykorzystaniem ramienia pomiarowego firmy ROMER. W pracy została omówiona metodologia pomiarów, przedstawiono uzyskane wyniki oraz przeprowadzono ich analizę.

**Słowa kluczowe:** samochód, koło kierowane, prototypowy przyrząd pomiarowy, pomiary współrzędnościowe, ramię pomiarowe ROMER

## 1. Introduction

An analysis of car movement parameters is one of the fundamental issues of stability and steerability. Change of the forces generated at the wheel-road contact is dependent on many factors associated with tyre, suspension and steering system construction. Steering wheels are carried out through the spatial mechanisms with flexible constraints [1]. The flexibility is the reason that during a car's movement along the same path, at different speeds, the real kinematic steering ratio changes; a significant difference between the real and theoretical steering angles appears. The measurement of real steering and camber angles in experimental car studies has a significant value. The results of these measurements are used to work out the relationships between car movement parameters as well as for stability and steerability valuation [2–4]. The measurement of the position and orientation of the wheel relative to the car body is very difficult, only a few studies on this topic can be found in the literature [2, 5–9]. The measurement is complicated and the measured values are not obtained directly but as a result of complex calculations.

The best known devices that allow the measurement of the position and orientation of the steered wheel relative to the car body are the Datron RV-3 and RV-4 instruments [10].

This paper concerns the determination of the initial configuration of the mechanism of a working model of a prototype instrument for linear and angular displacements of steered wheel measurement.

## 2. Proposed instrument for translation and rotation of steered wheel measurement

The proposed instrument for measuring the translation and rotation of a steered wheel is composed of two plates: external and internal, connected with nine links with linear displacements sensors built in. The external plate (Fig. 1) is fixed to the vehicle body, while the inner plate (Fig. 2) is kinematically connected with the axis of the steered wheel hub. The connection is made using bearing hub. The links of the instrument are attached to the both plates via ball joints, there are 9 joints named  $H_i$ ,  $i = 1-9$  in the case of the external plate and 3 joints named  $D_j$ ,  $j = 1-3$  in the case of the inner plate. A characteristic feature of the joints  $D_j$  is that each of them realizes the function of three ball joints with a common centre.

The measurement of angular and linear displacements of a steered wheel of a car, using the prototypical instrument, requires knowledge of the initial configuration of its mechanism. For this purpose it is necessary to know the coordinates of the ball joints  $D_j$ ,  $j = 1-3$  and  $H_i$ ,  $i = 1-9$  in a Cartesian coordinate system  $\{x, y, z\}$  attached to the vehicle body. The origin of the system is located at the external plate fixed to the vehicle body (Fig. 1). The coordinates of ball joints centres  $H_i$ ,  $i = 1-9$  were determined using the coordinate measurement method, while the coordinates of the centres of the ball joints  $D_j$ ,  $j = 1-3$  were calculated using mathematical dependences (see Equations (2) and (3)).

An overview of the prototype instrument attached to a car wheel is shown in Fig. 4.

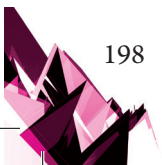

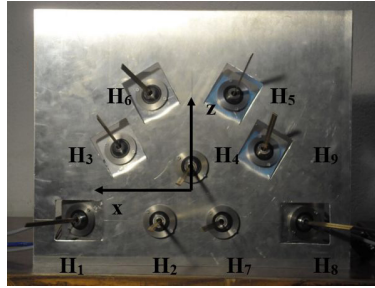

Fig. 1. The external plate of the prototypical instrument for measurement of linear and angular displacements of the steered wheel in overview. The Cartesian coordinate system and the positions of the ball joints  $H_i$ ,  $i = 1-9$  were marked in the photo

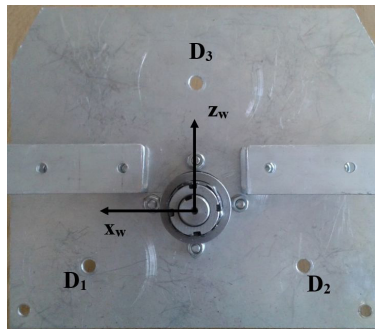

Fig. 2. An overview of the internal plate of the prototypical instrument for measurement of the linear and angular displacements of the steered wheel. Positions of the ball joints  $D_j$ ,  $j = 1-3$  and the Cartesian coordinate system connected with the plate is shown (The  $y_w$  - axis coincides with  $y$  - axis of the coordinate system connected with the external plate)

The plain bearings, shown in Fig. 3, were used as the joints  $D_j$ ,  $j = 1-3$  and  $H_i$ ,  $i = 1(9)$ .

a)



b)

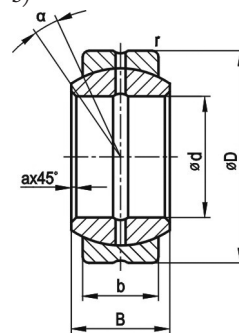

$d$ [mm]	$D$ [mm]	$B$ [mm]	$b$ [mm]	$r$ [mm]	$a$ [mm]	$\alpha$ [°]
16	32	21	15	0.8	0.3	15

Fig. 3. Spherical plain bearings ISKRA PGE 16X [11] used for fixing the links of the instrument to the external and internal plate: a) overview b) dimensions

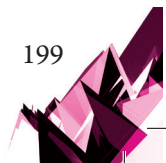



Fig. 4. An overview of the prototype measuring instrument attached to the car wheel

### 3. Determination of coordinates of characteristic points of instrument's mechanism

The coordinates of points  $H_i$ ,  $i = 1-9$  were determined using a ROMER measuring arm [12] shown in Fig. 5.

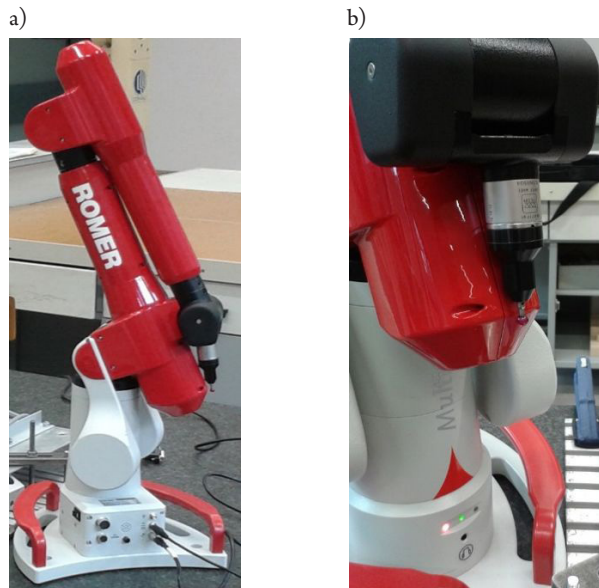

Fig. 5. ROMER measuring arm used to determine the coordinates of points  $H_i$ , for  $i = 1-9$ :  
a) overview b) close-up of the ruby ball

The basic parameters of the portable measuring arm are given below [12]:

- ▶ measuring range: 1.2 m,
- ▶ calibrated and certified according to ISO 10360-2,
- ▶ accuracy:  $MPEE = 5 + L/40 \leq 18 \mu\text{m}$ ;  $MPEP = 8 \mu\text{m}$ ; where  $L$  – length,
- ▶ operation temperature: 0–50°C,
- ▶ maximum relative humidity: 80% for temp. up to 31°C.

In order to measure, the plate with ball joints has been fixed on a granite measuring plate in such a way as not to cause deformation (Fig. 6).

a)



b)

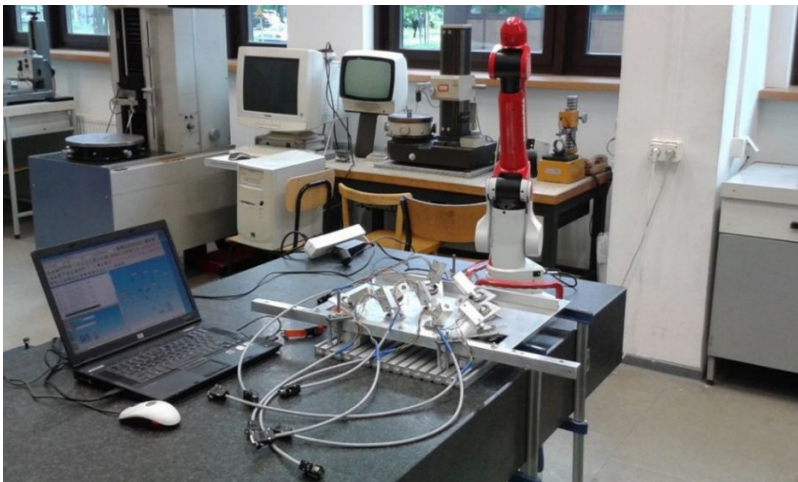
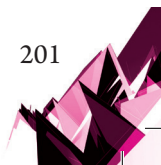

Fig. 6. The external plate of the measuring instrument (with ball joints fixing the optical linear displacements sensors) fixed on a granite measuring plate. The ROMER measuring arm and a computer with the appropriate software, on which disc the results of measurements were recorded are also visible



Before starting the actual measurements, the position of coordinate system, in which the coordinates of points  $H_i$ ,  $i=1-9$  were determined, should have been unambiguously specified. In order to do this, at first, at the surface of the measured plate the plane PLN1 was determined. Then, on that plane, two circles were defined (CIR1 and CIR2), between the centres of them the length LIN1 was constructed. Axes  $x$  and  $z$  are on the plane PLN1 and their origin was established at the point PNT3. The  $y$ -axis is coincided with a normal vector to the plane PLN1. Its origin was also established at the point PNT3, while its sense was directed in such a way that the coordinate system is right-handed and orthogonal.

Fig. 7 shows a screenshot of the computer program with which the results of the measurements were recorded. The features that were used to construct the coordinate system are visible.

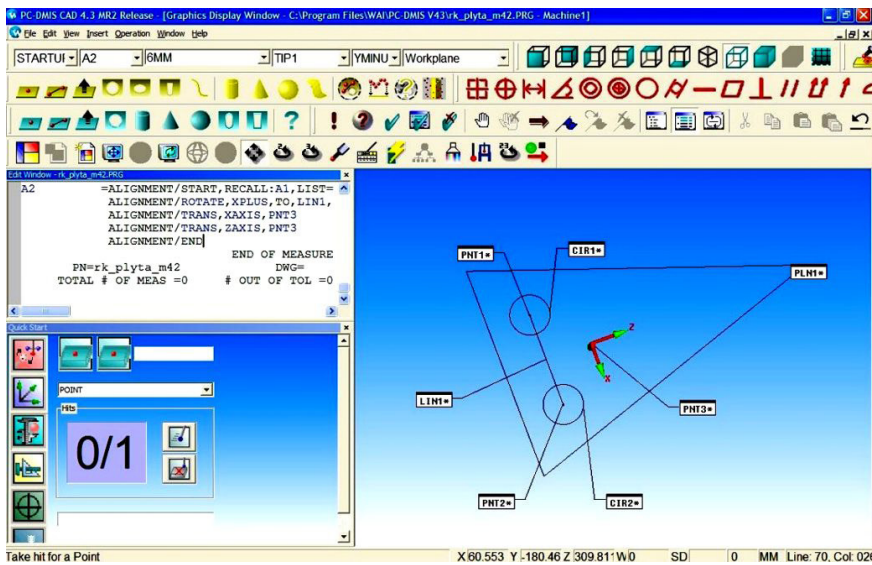

Fig. 7. The screenshot of the computer program with which the results of the measurements carried out using ROMER measuring arm were recorded. The plane PLN1, circles CIR2 and CIR2, length LIN1, the origin of the coordinate system PNT3, the directions and senses of  $x$  and  $z$  axes are shown. The direction and sense of axis  $y$  were specified in such a way that the coordinate system is right-handed and orthogonal

The coordinates of centres of the ball joints  $H_i$ ,  $i=1-9$  were determined by measuring the outer surfaces of inner rings of spherical plain bearings (Fig. 3). These surfaces are fragments of the sphere's outline, their measurement consisted in pointing, using the ruby ball of the ROMER measuring arm, eight points, on the basis of which the program determined the diameter, the coordinates  $x$ ,  $y$ ,  $z$  of the spheres centres, and hence the coordinates of the centres of the ball joints  $H_i$ ,  $i=1-9$  in the pre-determined Cartesian coordinate system. To increase the accuracy, the measurement of each surface was conducted three times, then the averages of the results obtained, which were taken as the requested coordinates of ball joints centres  $H_i$ ,  $i=1-9$ , were determined.

Fig. 8 shows an operator of ROMER measuring arm during the measurements.

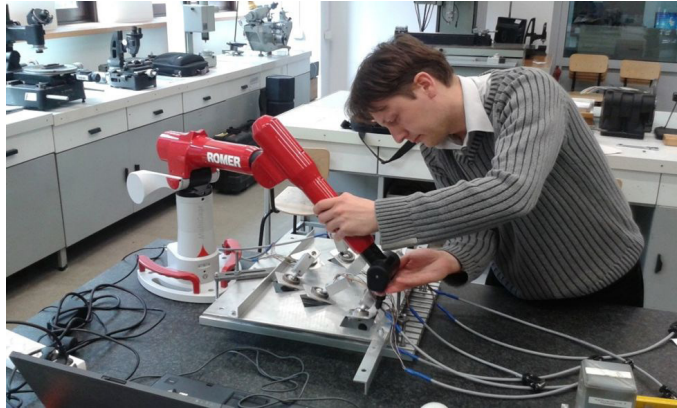
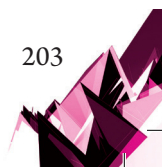

Fig. 8. The measurement of the coordinates of the ball joints  $H_i$ ,  $i = 1(9)$  centres using the ROMER measuring arm

The measurements results are summarized in Tab. 1.

Table 1. The results of the measurements of the coordinates of centres of ball joints  $H_i$ ,  $i = 1-9$  obtained using ROMER measuring arm. The results were measured with an accuracy of three decimal places. In terms of an aim realization, they were rounded to one decimal place

Ball joint	Coordinate	Measurement 1 mm	Measurement 2 mm	Measurement 3 mm	Average mm	Standard deviation mm
1	2	3	4	5	6	7
$H_1$	$x_{H1}$	113.4	113.6	113.6	113.5	0.08
	$y_{H1}$	-11.3	-11.2	-11.2	-11.2	0.05
	$z_{H2}$	61.5	61.0	61.0	61.2	0.25
$H_2$	$x_{H2}$	177.9	177.9	178.0	177.9	0.03
	$y_{H2}$	-11.9	-11.9	-11.7	-11.8	0.10
	$z_{H1}$	-49.5	-50.0	-50.0	-49.8	0.28
$H_3$	$x_{H3}$	50.1	50.1	50.1	50.1	0.02
	$y_{H3}$	1.1	1.2	1.1	1.1	0.09
	$z_{H3}$	-49.8	-50.2	-50.2	-50.1	0.22
$H_4$	$x_{H4}$	-0.2	0.0	0.0	-0.1	0.09
	$y_{H4}$	1.3	1.3	1.3	1.3	0.02
	$z_{H4}$	36.9	36.5	36.6	36.7	0.22



1	2	3	4	5	6	7
<b>H<sub>5</sub></b>	$x_{H5}$	-65.2	-65.0	-64.9	-65.0	0.17
	$y_{H5}$	-10.9	-11.1	-11.1	-11.0	0.09
	$z_{H5}$	146.9	146.8	146.8	146.8	0.09
<b>H<sub>6</sub></b>	$x_{H6}$	63.2	63.6	63.7	63.5	0.24
	$y_{H6}$	-10.3	-10.3	-10.3	-10.3	0.04
	$z_{H6}$	147.7	147.3	147.3	147.4	0.22
<b>H<sub>7</sub></b>	$x_{H7}$	-114.0	-113.9	-113.9	-114.0	0.08
	$y_{H7}$	-12.9	-12.9	-12.9	-12.9	0.04
	$z_{H7}$	59.3	59.3	59.3	59.3	0.04
<b>H<sub>8</sub></b>	$x_{H8}$	-177.6	-177.6	-177.6	-177.6	0.05
	$y_{H8}$	-12.6	-12.4	-12.5	-12.5	0.09
	$z_{H8}$	-50.5	-50.6	-50.6	-50.6	0.04
<b>H<sub>9</sub></b>	$x_{H9}$	-49.8	-49.8	-49.8	-49.8	0.03
	$y_{H9}$	1.1	1.0	1.1	1.1	0.06
	$z_{H9}$	-49.9	-50.1	-50.0	-50.1	0.10

The standard deviation, for each measurement, was determined according to the formula:

$$s = \sqrt{\frac{(x_k - \bar{x})^2}{n-1}} \quad (1)$$

where:

- $s$  – experimental standard deviation,
- $x$  – measured value of each coordinate,
- $\bar{x}$  – arithmetic mean of all measurements of each coordinate,
- $k$  – number of each measurement:  $i = 1-3$ ,
- $n$  – number of measurements,  $n = 3$ .

The determined values of the coordinates of the fixing points of the instrument's links to the external plate are shown below in millimetres:

$H_1(113.6, -11.2, 61.0)$ ;  $H_2(177.9, -11.8, -50.0)$ ;  $H_3(50.1, 1.1, -50.2)$ ;  $H_4(0.0, 1.3, 36.5)$ ;  $H_5(-64.9, -11.1, 146.8)$ ;  $H_6(63.7, -10.3, 147.3)$ ;  $H_7(-113.9, -12.9, 59.3)$ ;  $H_8(-177.6, -12.4, -50.6)$ ;  $H_9(-49.8, 1.1, -50.0)$ .

Shows the window of the computer program which recorded the measurement data, the positions of all ball joints fixing the external plate with the measuring instrument's links are visible. The ball joints were marked as SPH1–SPH9.

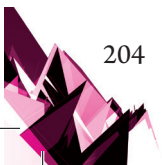



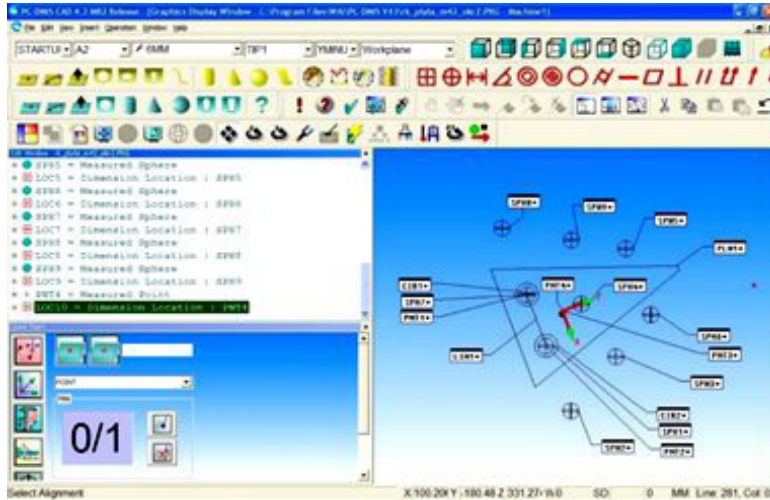

Fig. 9. Window of the computer program which recorded the measurements data. The coordinate system, objects that were used to build it (See Fig. 5) and the positions of ball joints, which coordinates were searched are shown (Symbols SPH1–SPH9)

The coordinates of centres of the ball joints  $D_j$ , in coordinate system connected with the external plate, were determined on the basis of known dimensions of the internal plate, the distance between the plates and the coordinates of centres of the ball joints  $H_j$ . It was assumed that the plates were parallel and had the same angular orientation. Fig. 10 shows a schematic view of the internal plate with the dimensions needed to calculate the coordinates of ball joints  $D_j, j = 1-3$  centres.

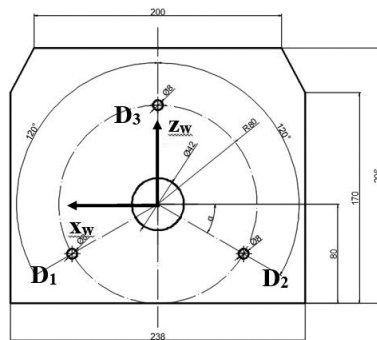
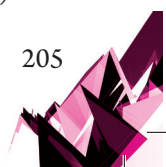

Fig. 10. Schematic view of the internal plate. Dimensions needed to calculate the coordinates of centres of the ball joints  $D_j, j = 1-3$  are shown

The coordinates  $x_w$  and  $z_w$  were calculated on the basis of basic geometrical relationships (for  $\alpha = 60^\circ$ ):

$$x_{D1} = -x_{D2} = R \cdot \cos(\alpha) = 80 \cdot 0.5 = 40 \text{ mm} \quad (2)$$

$$z_{D1} = -z_{D2} = R \cdot \sin(\alpha) = 80 \cdot \frac{\sqrt{3}}{2} = 69.3 \text{ mm} \quad (3)$$



The coordinates  $y_{D1}, y_{D2}, y_{D3}$  were calculated on the basis of the known distance between internal and external plates and the dimensions of the ball joints  $D_j$ .

The determined coordinates of centres of ball joints  $D_j, j = 1-3$  are presented below in millimetres:

$D_1(69.3, -232.2, -40.0); D_2(-69.3, -232.2, -40.0); D_3(0.0, -232.2, 80.0)$ .

Knowing the coordinates of ball joints  $H_i$  and  $D_j$ , the initial lengths of the instrument's links were calculated:

$$\vec{r}_{D_1, H_i}^T \cdot \vec{r}_{D_1, H_i} = l_{D_1, H_i}^2, \quad i = 1, 2, 3 \quad (4)$$

$$\vec{r}_{D_2, H_i}^T \cdot \vec{r}_{D_2, H_i} = l_{D_2, H_i}^2, \quad i = 7, 8, 9 \quad (5)$$

$$\vec{r}_{D_3, H_i}^T \cdot \vec{r}_{D_3, H_i} = l_{D_3, H_i}^2, \quad i = 4, 5, 6 \quad (6)$$

#### 4. Summary

It is necessary to know the coordinates of the ball joints centres  $H_i, i = 1-9$  and  $D_j, j = 1-3$  and the lengths of links of the proposed instrument's mechanism at the beginning of measurements of linear and angular displacements of a steered wheel. The coordinates of nine ball joints  $H_i$  were determined using a ROMER measuring arm, an accuracy of three decimal places was obtained, but in terms of aim realization, they were rounded to one decimal place. The measurement of each coordinate  $x, y, z_i$  was repeated three times, than an average and standard deviation were calculated. The average standard deviation obtained a value of 0.1 mm. On the basis of results of these measurements and the known distance between the instrument's plates, the coordinates of the centres of the ball joints  $D_j$  and the lengths between plates were calculated.

#### References

- [1] Reimpell J., Betzler W., *Podwozia samochodów. Podstawy konstrukcji*, WKŁ, Warszawa 2002.
- [2] Janczur R., *Analityczno-eksperymentalna metoda badań sterowności samochodu*, Politechnika Krakowska, Ph.D. Dissertation, Kraków 2002.
- [3] Struski J., *Quasi-statyczne modelowanie sterowności samochodu*, Wydawnictwo PK, Monografia 144, Kraków 1993.
- [4] Struski J., *Przyrząd do pomiaru dynamicznego kąta skrętu koła kierowanego* Patent nr P-267693.
- [5] Blumenfeld W., Schneider W., *Opto-elektronisches Verfahren zur Spur- und Sturzwinkelmessung am fahrenden Fahrzeug*, ATZ 87 1, 1985, 17-21.

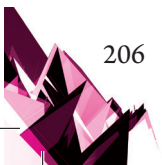

- [6] Struski J., Kowalski M., *Podstawy teoretyczne uogólnionych zagadnień z zakresu parametryzacji układów prowadzenia kół względem nadwozia*, Technical Transactions, 6-M/2008, 119–129.
- [7] Struski J., Wach K., *Analiza mechanizmu przyrządu pomiarowego do wyznaczania translacji i rotacji zwrotnicy z kołem kierowanym*, Technical Transactions, 3-M/2008, 87–100.
- [8] Struski J., Wach K., *Teoretyczne podstawy wyznaczania przemieszczeń liniowych oraz kątowych koła kierowanego*, Czasopismo Logistyka-Nauka [Electronic document], – Optic Disc CD, Vol. 4, 2015, 5840–5849.
- [9] Wach K., *The theoretical analysis of an instrument for linear and angular displacements of the steered wheel measuring*, IOP Conference Series: Materials Science and Engineering IOP, Vol. 148(1), 2016.
- [10] CORSYS- DATRON RV-4 *Wheel Vector Sensor for Simultaneous Measurement of all Wheel Positions and Orientations in 5 Axes*, User manual, Vol. I, Wetzlar, Germany 2008.
- [11] Spherical plain bearings ISKRA PGE 16X datasheet: [http://www.iskra-zmils.com.pl/pliki\\_inne/14.pdf](http://www.iskra-zmils.com.pl/pliki_inne/14.pdf) (access: 28.03.2017).
- [12] [http://apps.hexagon.se/downloads123/hxmt/romer/romer-multi-gage/brochures/ROMER%20Multi%20Gage\\_brochure\\_pl.pdf](http://apps.hexagon.se/downloads123/hxmt/romer/romer-multi-gage/brochures/ROMER%20Multi%20Gage_brochure_pl.pdf) (access: 28.03.2017).
- [13] Śladek J., *Dokładność pomiarów współrzędnościowych*, Wydawnictwo PK, Kraków 2012.
- [14] Ratajczyk E., *Współrzędnościowa technika pomiarowa*, Oficyna Wydawnicza Politechniki Warszawskiej, Warszawa 2005.

