

KRZYSZTOF W. KSIĄŻYŃSKI*

SIMPLE DESCRIPTION OF GROUNDWATER RECHARGE THROUGH THE VADOSE ZONE

PROSTY OPIS ZASILANIA WÓD PODZIEMNYCH PRZEZ STREFĘ AERACJI

Abstract

The paper presents the calculation rules for infiltration into the saturated zone using a simplified piston model. It has been indicated that recharge is the same as during free infiltration for unsaturated infiltration and that a new system of boundary conditions has been proposed for saturated infiltration and redistribution of moisture. The volumes of infiltration calculated for those cases have also been compared with the results obtained in a simulation based on the conductivity equation, showing convergence.

Keywords: groundwater recharge, piston model, supported infiltration, Richards equation

Streszczenie

W artykule przedstawiono zasady obliczeń infiltracji do strefy pełnego nasycenia z użyciem uproszczonego modelu tłokowego. Wskazano na niezmienną zasilanie w stosunku do infiltracji swobodnej przy nienasyconym charakterze infiltracji i zaproponowano nowy układ warunków brzegowych przy charakterze nasyconym i przy redystrybucji wilgoci. Porównano również wielkości infiltracji wyliczone dla tych przypadków z wynikami uzyskiwanymi z symulacji opartej na równaniu przewodnictwa, wykazując zbieżność.

Słowa kluczowe: zasilanie wód podziemnych, model tłokowy, infiltracja podparta, równanie Richardsa

* Assoc. Prof. D.Sc. Ph.D. Eng. Krzysztof W. Książczyński, Institute of Water Engineering and Water Management, Faculty of Environment Engineering, Cracow University of Technology.

List of symbols

$c(h_s)$	–	capillary capacity (soil water capacity) [m^{-1}]
D_w	–	moisture diffusion coefficient [$m^2 s^{-1}$]
H	–	water head [m]
H_k	–	water head on the limit of capillary height [m]
h_s	–	suction head [m]
h_g	–	water depth on the soil surface [m]
h_k	–	capillary height [m]
$k(\theta)$	–	effective hydraulic conductivity of soil as the function of its moisture [$m s^{-1}$]
k_n	–	maximum hydraulic conductivity for wetting [$m s^{-1}$]
k_o	–	hydraulic conductivity [$m s^{-1}$]
m_a	–	thickness of vadose zone [m]
n	–	porosity of soil [$m^3 m^{-3}$]
S	–	hydraulic gradient [m]
t	–	time [s]
v	–	seepage velocity [$m s^{-1}$]
v_e	–	evapotranspiration [$m s^{-1}$]
v_f	–	wetting front velocity [$m s^{-1}$]
v_g	–	ground absorbency [$m s^{-1}$]
v_k	–	seepage velocity in capillary zone [$m s^{-1}$]
v_r	–	surface recharge [$m s^{-1}$]
v_w	–	recharge on the groundwater table [$m s^{-1}$]
z	–	vertical coordinate [m]
z_i	–	wetting front coordinate [m]
z_k	–	coordinate of capillary zone [m]
θ	–	soil moisture [$m^3 m^{-3}$]
θ_n	–	maximum moisture for wetting [$m^3 m^{-3}$]
θ_r	–	moisture near the surface [$m^3 m^{-3}$]
θ_w	–	residual moisture [$m^3 m^{-3}$]

1. Introduction

Groundwater recharge usually occurs through the unsaturated zone, the so-called vadose zone. Infiltration of water from the surface results in complex changes in moisture within that zone, which determine the delay and equalization of groundwater recharge. Storage capacity of the saturated zone is low (which results from the low compressibility of water and the soil skeleton structure), thus the transformation of precipitation into groundwater outflow depends on the vadose zone storage capacity. In this situation, a correct description of the processes occurring within that zone is very significant in the cognitive aspect and facilitates an effective simulation of the entire transformation process.

This paper contains an attempt to describe the groundwater recharge changes using a general seepage equation and a simplified piston model. Both models have long been used

for describing motion within the vadose zone. However, the issue of feeding is relatively less identified in the piston model. A number of new factors have a significant effect on its course.

2. Support model assumptions

Repeated precipitation events, separated by rainless periods, result in an increase in soil moisture within the subsurface area of the vadose zone, dependent on the intensity and course of precipitation. Simultaneously, under the influence of gravity and capillary forces, the moisture redistribution process takes place. It takes place through propagation of high moisture deeper into the soil column, while for a certain period, sections with constant moisture gradients might occur, elongating at constant rates. Such phenomena are called “wetting fronts” and constitute the basis for simplified descriptions. It is the so-called “free infiltration”. As far as groundwater recharge is concerned, reaching the saturated zone by those fronts is highly important and referred to as the “support”.

When a wetting front reaches a closed capillary zone (fully saturated), distinct changes occur in the infiltration rate and saturation zone feeding. Both of these variables may be inhibited due to hydraulic slope limiting caused by new motion boundary conditions. This process is called supported infiltration, to differentiate it from free infiltration in which wetting fronts occur.

2.1. A model based on the general seepage equation

A generalization of the Darcy’s formula, also valid for the vadose zone, is the Buckingham-Darcy equation, which has the following form for vertical motion (infiltration):

$$v = -k(\theta) \frac{\partial H}{\partial z} \quad (1)$$

Effective hydraulic conductivity of soil $k(\theta)$ is the function of its moisture [1], and in fully saturated conditions it has the value of hydraulic conductivity k_o . When the formula is inserted to the equation of continuity, the equation of motion is obtained:

$$\frac{\partial}{\partial z} \left[k(\theta) \frac{\partial H}{\partial z} \right] = \frac{\partial \theta}{\partial t} \quad (2)$$

It is a one-dimensional version of the Richards equation [5], giving a precise description of isothermal seepage for both saturation zones [6]. However, it cannot be solved directly, as it contains two unknowns – hydraulic head H and moisture θ . They are correlated through the soil-moisture retention characteristics, since $H = -z - h_s$ (z – vertical coordinate, h_s – suction head), thus the solution may be obtained by substituting moisture with that characteristics $\theta(h_s)$. As a result, a general seepage equation (conductivity equation) is obtained.

As for storativity (right side of equation 2), moisture θ must be treated as a composite function:

$$\frac{\partial \theta}{\partial t} \equiv \frac{\partial \theta}{\partial h_s} \frac{\partial h_s}{\partial t} \equiv \frac{\partial \theta}{\partial h_s} \frac{\partial (z-H)}{\partial t} \equiv -\frac{\partial \theta}{\partial h_s} \frac{\partial H}{\partial t} \equiv c(h_s) \frac{\partial H}{\partial t} \quad (3)$$

where $c(h_s) = -\partial \theta / \partial h_s$ is the capillary capacity (soil water capacity), which is actually a suction head h_s derivative of the soil-moisture retention characteristics. Such form of the retention section has been introduced by Richards [5]. The c parameter may be generalized for the saturation zone, where it corresponds to the specific storativity. In motion calculations for unconfined seepage, its value may be taken as zero. This way, the equation of motion takes the following form [2]:

$$\frac{\partial}{\partial z} \left[k(h_s) \frac{\partial H}{\partial z} \right] = c(h_s) \frac{\partial H}{\partial t} \quad (4)$$

An identical equation describes thermal conductivity, thus the formula presented above is referred to as the conductivity equation. Another name in use is the general seepage equation, since it describes motion in both saturation zones. Simulations performed using formula (4) are usually based on a discrete model. In this paper, they are used for verification of the piston model.

2.2. Simplified piston model [4]

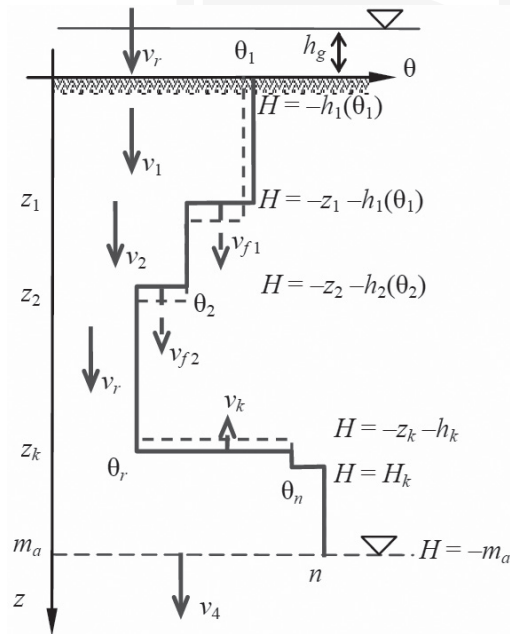

The piston model assumes invariability of vertical moisture redistribution behind the soil wetting front (piston motion). In the traditional model, front course is simplified to a local moisture increase from the initial value θ_{i+1} to the value of θ_i (Fig. 1) actually reached in a certain distance behind the front. The initial moisture must therefore be lower than the maximum saturation value θ_n – it is free infiltration. The infiltration rate is calculated depending on the recharge conditions on the surface.

Fig. 1. Scheme of vertical moisture redistribution in the piston model

Submerged infiltration occurs when surface recharge (v_r) is higher than ground absorbency (v_g). Moisture behind the front reaches the maximum moisture value θ_n for wetting, while infiltration rate results from the Darcy's formula and boundary conditions:

$$v_g = k_n \left(1 + \frac{h_g + h_k}{z_1} \right) \quad (5)$$

Saturated infiltration occurs when recharge is lower than ground absorbency, but higher than the maximum hydraulic conductivity for wetting (k_n). This situation is similar to submerged infiltration, the difference is the lack of surface submergence, while the infiltration rate corresponds to the recharge value:

$$v_r = \min \left[v_r; k_n \left(1 + \frac{h_k}{z_1} \right) \right] \quad (6)$$

The second value, here described with the formula, corresponds to the limit of ground absorbency, above which surface submergence and submerged infiltration occur.

Unsaturated infiltration occurs when recharge is lower than maximum hydraulic conductivity for wetting. Moisture behind the front is constant and lower than the full saturation value, while the infiltration rate corresponds to the hydraulic slope with the value of 1 (due to constant moisture behind the front). The Buckingham-Darcy equation determines the dependence of these values:

$$v_r = k(\theta_2) \quad (7)$$

which allows to calculate the value of moisture behind the front.

Front velocity results from the water balance within the wetting front:

$$v_{fi} = \frac{v_i - v_{i+1}}{\theta_i - \theta_{i+1}} \quad (8)$$

The dependence is valid for each infiltration regime.

Moisture redistribution occurs when recharge is lower than it is necessary to maintain previous soil moisture, which means that it depends on its current effective hydraulic conductivity. Water outflow guaranteeing front propagation corresponds to unsaturated infiltration (equation 7) and is higher than surface recharge, as a result of which moisture behind the front gradually decreases. Moisture changes may be calculated on the basis of the column balance.

The piston model (PM) presented here has been thoroughly verified using available measurement data [4]. This model describes a version of the classic free infiltration in a simplified way, and cannot be used directly to describe supported infiltration. It is only

possible when several additional assumptions are made, which result from the analysis of the actual course of this process.

2.3. Capillary rise zone moisture

Below the unsaturated zone is the capillary rise zone, which has the height of h_k over the groundwater level (at the depth of m_a), in static conditions. Moisture of the permanent capillary zone corresponds to full saturation of soil pores ($\theta = n$), due to constant washing by vertical seepage. Moisture of a zone occurring sporadically after precipitation corresponds to the maximum saturation for wetting ($\theta = \theta_n$), which results from the presence of air entrapped in the smallest pores. Further wetting of this zone ($\theta > \theta_n$) is impossible due to hysteresis, which explains its name – closed capillary zone. In fact, as a result of diffusion of entrapped air, a certain moisture increase occurs, but it is very slow and not taken into account in this case.

Over the so-called closed capillary zone is the open zone, with moisture decreasing with the height, up to the level of residual moisture θ_w , that depends on the history of the infiltration process. Assuming a rapid moisture change within the front in the PM leads to omitting this zone, which is followed by local errors in determining the rate and moisture. However, it has only a slight influence on the description of the course of groundwater recharge.

3. Capillary infiltration

The height of the capillary zone is determined by the recharge from the vadose zone, regardless of whether it is infiltration or the effect of the motion of the groundwater level. In the case of lack of recharge ($v_r = 0$), closed capillary zone is stabilized at the height of standard capillary rise h_k , which is at the level $z_k = m_a - h_k$, and being stable, it reaches full saturation moisture ($\theta = n$, Fig. 2). The flow through this zone causes changes in its height and its moisture.

Traditional solutions to this issue regard only the water level motion, with the assumption that no hysteresis occurs, which is particularly important with the so-called active capillary rise. It occurs when the level rises, as a result of which the capillary zone shortens and negative hydraulic slope is generated. It allows the upper boundary of the closed capillary zone to rise following the groundwater level. However, the outflow to the vadose zone may occur only when the moisture gradient exceeds the value of gravitational slope. Such a situation may occur locally near the soil surface as a result of strong evapotranspiration (section 9). Below, only moisture redistribution may occur, causing a slow decrease in the capillary zone recharge, until static state ($v_k = 0$) is reached. Consequently, considering this situation is practically insignificant.

A passive rise occurs with positive slope within the rise zone, which is when the groundwater level drops, or when a groundwater recharge occurs (Fig. 2, $v_r > 0$). The capillary rise zone gradually extends ($z_k < m_a - h_k$) until hydraulic slope necessary to maintain flow continuity appears. The rate of rise of the z_k level is determined by the balance, so it depends on recharge intensity.

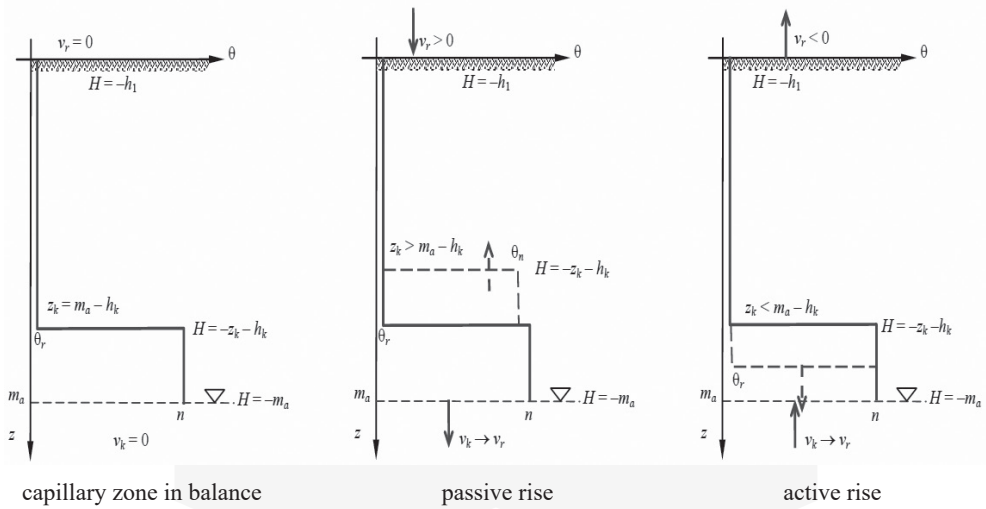

Fig. 2. Schemes of changes in the range of the capillary rise zone

Calculating the rate of outflow from the capillary zone in short-term rain infiltration conditions requires taking hysteresis into account, which leads to the formation of a new layer with the moisture value of θ_n over the stationary zone with the moisture value n . The traditional solution known from hydraulic engineering assumes stability of infiltration, which is connected with the loss of moisture diversification (also over h_k $\theta = n$). Such a situation occurs when the groundwater level drops, as the rise zone extends at the cost of the fully saturated zone.

In the case of non-steady infiltration, with a stabilized groundwater level, this solution is not correct. Assuming that the stationary capillary zone is stable, which implies that it is fully saturated and has the height of h_k , while a new moisture value $\theta_n < n$ (Fig. 2) appears above it, the following equation of flow continuity in zones with variable moisture:

$$v_k = k_n \frac{-z_k - h_k - H_k}{m_a - h_k - z_k} = k_o \frac{H_k + m_a}{h_k} \quad (9)$$

may be used to calculate the value of hydraulic head H_k at the boundary of different effective conductivity zones ($H_k < 0$, as it is below the soil level):

$$v_k = k_o \frac{H_k + m_a}{h_k} \rightarrow H_k = h_k \frac{v_k}{k_o} - m_a \quad (10)$$

Substituting to the equation of continuity will give:

$$v_k = k_n \frac{-H_k - z_k - h_k}{m_a - z_k - h_k} = k_n \frac{-h_k \frac{v_k}{k_o} + m_a - z_k - h_k}{m_a - z_k - h_k} = k_n \left(1 - \frac{v_k}{k_o} \frac{h_k}{m_a - z_k - h_k} \right) \quad (11)$$

The equation may be used to derive a formula of the rate of infiltration through the rise zone:

$$v_k = k_n \frac{m_a - z_k - h_k}{m_a - z_k - h_k + h_k \frac{k_n}{k_o}} = k_n \left(1 - \frac{h_k}{\frac{k_o}{k_n} [m_a - z_k - h_k] + h_k} \right) \cong$$

$$\cong k_n \left(1 - \frac{h_k}{2(m_a - z_k) - h_k} \right) \quad (12)$$

In the flow equilibrium conditions, i.e. when $v_k = v_r$, the wetting front stabilizes at the level:

$$z_k \cong m_a - \frac{h_k}{2} \left(1 + \frac{k_n}{k_n - v_w} \right) \quad (13)$$

The capillary zone is forming gradually as a result of the lack of equilibrium of water balance – limited outflow through the current zone height is lower than the recharge. Consequently, the process is asymptotic, with decreasing rate, until the equilibrium is reached. However, as a result of the recharge decrease, the balance of the capillary zone will be negative. It causes a lowering of the upper boundary of the zone, again asymptotically towards the new equilibrium. Thus, the equilibrium is actually never reached. For small values of the average yearly or seasonal feeding, the height of the stable capillary zone is only slightly different from the height of rise h_k .

When flow is prolonged, a slow increase in the soil moisture and conductivity mentioned above occurs, which causes gradual increase of its absorbency, until the hydraulic conductivity value k_o is reached.

4. Submerged infiltration

This infiltration regime occurs when recharge exceeds the value of ground absorbency ($v_r > v_g$, $h_g \geq 0$), irrespective of the range of the capillary rise zone ($z_k >, =$ or $< m_a - h_k$). In case of rapid runoff, the depth of water on the surface remains around zero ($h_g \cong 0$, Fig. 3).

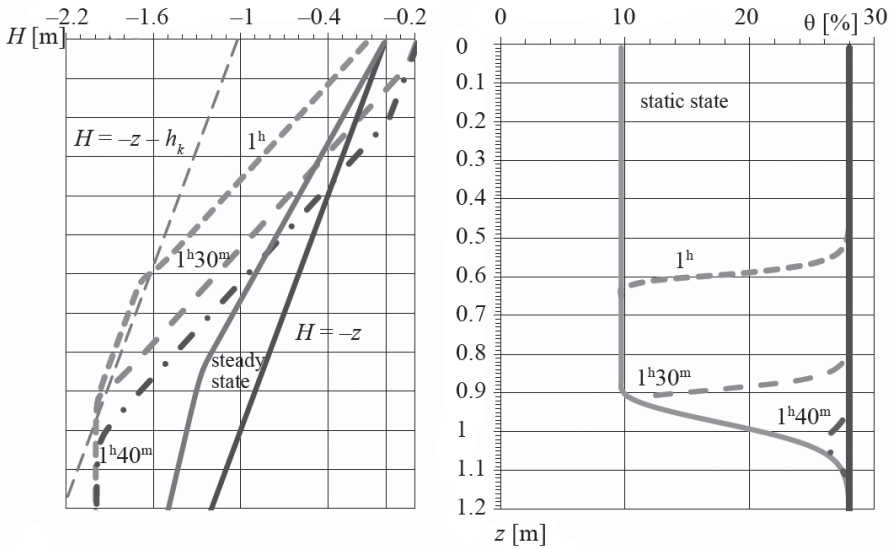

Fig. 4. Changes of moisture θ and hydraulic head H in submerged conditions, after support (discrete imulation)

For free infiltration, absorbency is described by formula (5), so after support, its value decreases, while the runoff value increases. The decrease of absorbency also leads to the occurrence of lower values of hydraulic slope in both capillary zones. In Fig. 4, the blue line indicates the value of hydraulic head with constant moisture value θ_n in a column, while the grey line – with moisture increasing from θ_n to n (within the stable capillary zone). Proper recharge values may be calculated using formula (16).

4.2. Submerged supported infiltration process

In the initial phase of infiltration within the zone after the wetting front, the traditional model of submerged infiltration (formula 5) is applicable. The flow within the residual zone and within the capillary rise zone has the same course as in unsaturated infiltration. Runoff occurs due to the fact that precipitation intensity exceeds ground absorbency.

When both zones reach each other, i.e. $z_1 = z_k$ (Fig. 3), the infiltration zone becomes the capillary rise zone and the infiltration rate drops to the absorbency value (formula 16). Because retention is impossible, runoff recharge increases rapidly and almost stabilizes (provided that groundwater level remains unchanged). Over time, as air diffuses from the smallest soil pores, a slow increase of the infiltration rate occurs, towards the value of hydraulic conductivity ($v_g \rightarrow k_o$), but precipitations are never so long. It causes a proper slow decrease of runoff recharge.

5. Supported saturated infiltration

This infiltration regime appears when the recharge value exceeds the maximum value of effective hydraulic conductivity for wetting, but falls within the range of ground absorbcency ($k_n < v < v_g$), irrespective of the range of the capillary rise zone ($z_k >, = \text{ or } < m_a - h_k$). In such conditions, pressure guaranteeing full saturation is generated on the surface, but runoff does not occur ($-h_k \leq h_g < 0$, Fig. 5).

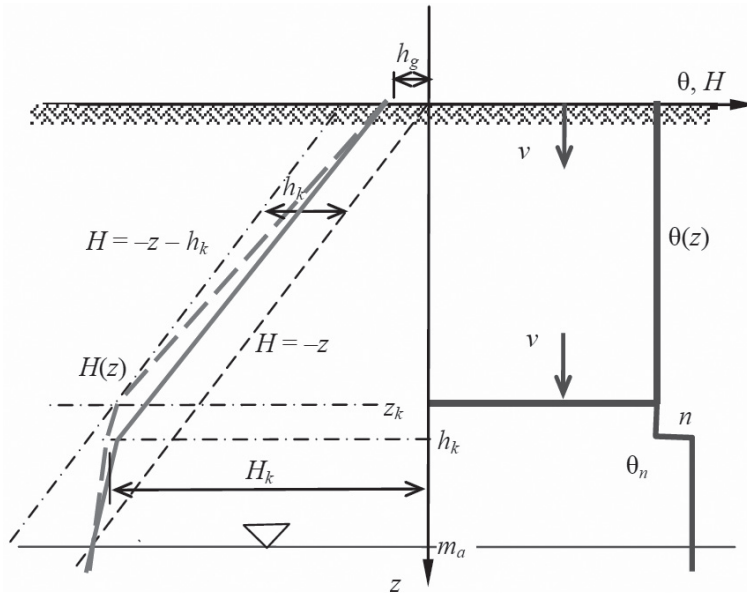

Fig. 5. Scheme of moisture θ and hydraulic head H changes in the piston model, during supported saturated infiltration

When support occurs, the infiltration zone and the capillary rise zone merge (Fig. 6), so the situation is similar to that observed during submerged infiltration. However, in this case, the boundary condition on the surface is the recharge value v_r . Rate compensation within these two zones with different conductivities leads to the following equation:

$$v_r = v = v_k \rightarrow v_r = k_n \frac{h_g - H_k}{m_a - h_k} = k_o \frac{H_k + m_a}{h_k} \quad (17)$$

that may be used for determining the hydraulic head at the zones boundary:

$$H_k = h_k \frac{v_r}{k_o} - m_a < 0 \quad (18)$$

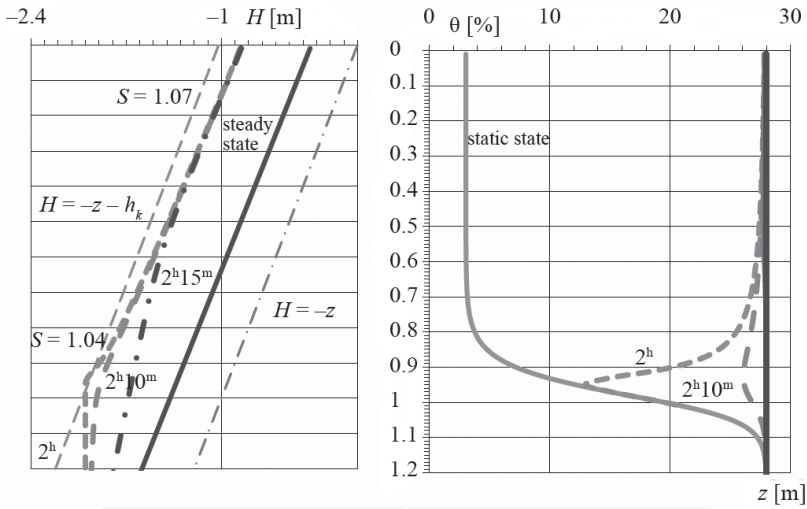

Fig. 6. Changes of moisture θ and hydraulic head H in supported saturated infiltration (discrete simulation)

as well as the equation to be satisfied by the rate of seepage:

$$v_r = k_n \frac{h_g + m_a - h_k \frac{v_r}{k_o}}{m_a - h_k} \rightarrow v_r = k_n \frac{h_g + m_a}{m_a - h_k + \frac{k_n}{k_o} h_k} \quad (19)$$

5.1. Pressure head on the surface

The previous equation may be used to determine the value of pressure head on the surface that is generated as a result of precipitation with the intensity of v_r :

$$\begin{aligned} h_g &= \frac{v_r}{k_n} \left(m_a - h_k + h_k \frac{k_n}{k_o} \right) - m_a = m_a \left(\frac{v_r}{k_n} - 1 \right) - h_k \left(\frac{v_r}{k_n} - \frac{v_r}{k_o} \right) \cong \\ &\cong m_a \left(\frac{v_r}{k_n} - 1 \right) - \frac{h_k}{2} \frac{v_r}{k_n} < 0 \end{aligned} \quad (20)$$

The pressure head value should not be higher than 0, as otherwise a proper layer of water would have to accumulate on the surface. Negative values, indicating suction head, cannot be lower than h_k , because the moisture value would drop below θ_n . In particular for recharge $v_r = k_n$, the suction head on the surface will be $h_g \cong -1/2 h_k$.

5.2. Ground absorbency v_g

Ground absorbency corresponds to $h_g = 0$ and is the **maximum value of recharge for this regime** (when it is higher, submerged infiltration takes place). A proper equation for submerged infiltration (formula 16) may be used, with the said value h_g inserted:

$$v_g = k_n \frac{m_a}{m_a - h_k + h_k \frac{k_n}{k_o}} \cong k_n \left(1 + \frac{h_k}{2 m_a - h_k} \right) \quad (21)$$

Therefore, ground absorbency also decreases in this case. When feeding is very intensive, it can lead to submergence of infiltration.

5.3. Supported saturated infiltration process

In the initial phase of infiltration behind the wetting front, the traditional model of saturated infiltration may be used (formula 6). The flow within the residual zone and the capillary rise zone has the same course as in unsaturated infiltration. When both zones reach each other ($z_1 = z_k$), the slope within the capillary rise zone increases rapidly (no retention), and the rate of infiltration in the entire column reaches the value of surface recharge. Actually, because of the open capillary zone, this process takes place until the zone is fully saturated, which takes several minutes (Fig. 6). It is related with the increase of the hydraulic head on the surface h_g (formula 20). If recharge intensity exceeds the absorbency value reduced as a result of the support (formula 21), this value will be positive and surface submergence will occur. Thus, submerged infiltration will take place, with intensity lower than the recharge.

Prolonged saturated infiltration causes a gradual removal of air entrapped in soil pores, with moisture increase until reaching the porosity value n . It leads to the increase of effective hydraulic conductivity of ground, and also its absorbency to the value of hydraulic conductivity k_o , similarly as during submerged infiltration.

6. Unsaturated infiltration

In the initial phase of infiltration behind the wetting front, the traditional model of unsaturated infiltration is applicable (free infiltration, formula 7). In the shrinking residual zone (with the initial moisture value), the seepage rate is calculated in the same way on the basis of residual moisture θ_w .

Water in capillaries remains under the influence of gravity and surface tension, so after the support of unsaturated infiltration the rate remains unchanged and unit slope is maintained ($v = k(\theta)$, Fig. 7). Only within the capillary zone does a new balance appear, with slope resulting from the new recharge value (section 3), for effective hydraulic conductivity during wetting $k_n = k(\theta_n)$.

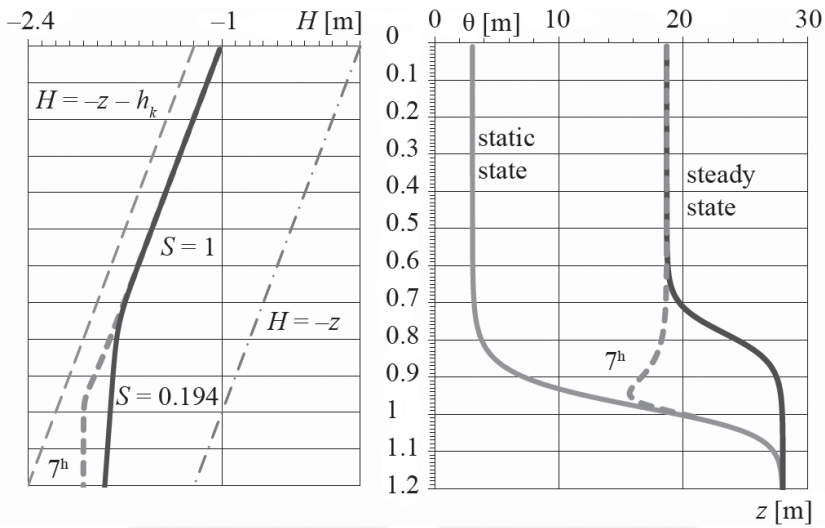

Fig. 7. Changes of moisture θ and hydraulic head H in supported unsaturated infiltration (discrete simulation)

In the model with the sharp wetting front, moisture within the front is constant until the moment of support: $\theta_w = \text{const}$, $v = k(\theta_w)$. Actually, the moisture value increases gradually downwards the column, until reaching θ_n , along the section defined by the steepness of soil characteristics and the recharge value. The height of such open capillary zone changes similarly as in the case of a closed zone (Fig. 7). Accordingly, support does not change the rate of flow, but only moisture distribution.

7. Residual infiltration

Residual infiltration is the infiltration between the last front z_1 and the capillary zone z_k . The moisture within this zone is the result of moisture redistribution in periods between precipitations. In this process, due to negative column balance, water slowly flows out of the vadose zone. When a new wetting front occurs during precipitation with intensity that guarantees positive balance ($v_r > k(\theta_r)$), redistribution is ceased because the flow to the residual zone compensates the outflow.

As it has been confirmed by the analysis of the actual course of the process, the slope within the column with constant residual moisture remains equal to 1, which is determined by constant suction head and invariability of moisture change trend. A similar process occurs in free infiltration, so just as in that case, the rate of infiltration corresponds with the effective hydraulic conductivity at a given moisture level $v = k(\theta_w)$. Consequently, it is the efficiency of the capillary zone recharge, or the other way round – the formula may be used in order to determine the moisture level within the residual zone, for a given recharge value, before the occurrence of a new wetting front.

8. Moisture redistribution

Moisture redistribution consists in the outflow of water from larger capillaries in the top part of the column and infiltration to its lower parts. As a result, the flow within the capillaries has the character of the flow supplied on the length, reaching the full efficiency at the end of the column, which is when $z = z_k$. When the recharge does not compensate the outflow to the capillary zone, the slope increases along with the depth, from the value corresponding to the current surface recharge to the value corresponding to the outflow. Within the capillary zone, the slope decreases along with the increase of conductivity at a given level, so that the maximum slope level occurs at the upper boundary of the open capillary zone. As a result, the suction head within the vadose zone drops only slightly, while the moisture value slightly increases downwards the column (Fig. 7), with a small departure from the assumptions of the piston model. That increase accelerates only within the open capillary zone.

In the piston model, vadose zone moisture θ_w is determined on the basis of its balance (to the depth of z_k), while the rate of the capillary zone recharge is calculated as in the case of free infiltration, which is on the basis of the moisture retention characteristics $v_k = k(\theta_w)$. The depth of the front z_k should be calculated on the basis of the rate of infiltration to the capillary rise zone, as described in section 3. Such a method of calculation gives results that are quite consistent with the actual values (Fig. 8), which is not provided by the free infiltration model (traditional).

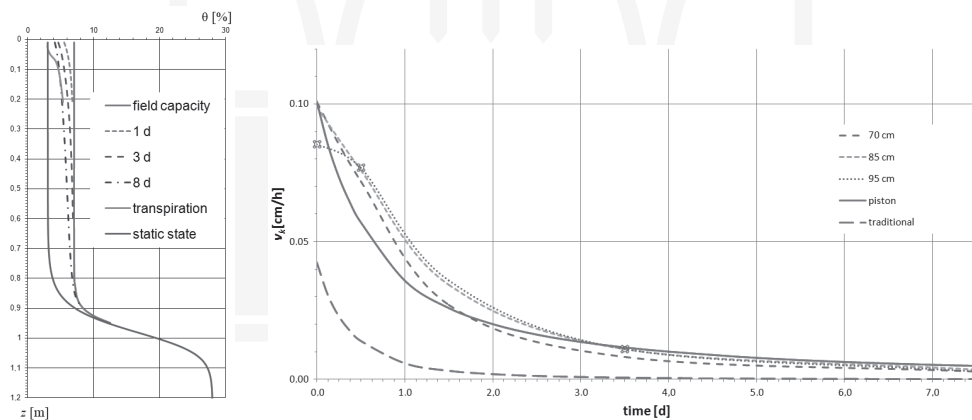

Fig. 8. Changes of the rate of the capillary zone recharge in moisture redistribution conditions for piston model and discrete simulation

9. Groundwater evaporation

Precipitation events appear periodically, while in times between them, moisture is constantly determined by redistribution. It occurs in the area above the first wetting front, or after its disappearance – above the residual zone. Thus, water outflow through the surface

may occur above the first front z_1 , or above the range of the residual zone (z_k). Outflow intensity corresponds to the current evapotranspiration v_e (i.e. $v_r = -v_e < 0$). The consequence of evaporation is the decrease in the moisture level. Thus, it is a process in which hysteresis occurs, just as in the case of moisture redistribution.

According to the Buckingham-Darcy equation, infiltration may be described as the sum of moisture diffusion and gravity flow:

$$v = -k(\theta) \frac{d(-h_s - z)}{dz} = D_w(\theta) \frac{d\theta}{dz} + k(\theta) \quad (22)$$

where $D_w(\theta)$ denotes the moisture diffusion coefficient. Water outflow towards the surface requires negative slope (upwards), and such situation is possible only when the suction head drop exceeds 100%, which is when a very large moisture decrease occurs, possible only within the several-centimeter thick sub-surface layer (Fig. 8, light blue line). Intensive drying of this layer causes an increase of its thermal insulation properties, which quickly impedes further evaporation. Only plants, thanks to their root systems, are capable of acquiring water from the quite extensive rhizosphere, for a certain time maintaining the outflow of moisture to the atmosphere. However, when boundary moisture level is exceeded within this layer, transpiration is also impeded [3]. With such moisture values, the water outflow is very small, so redistribution decays as well.

The piston model, being simplified, does not allow to include such local changes, determining only the average moisture value within the adhesion zone. While calculating the moisture value behind the wetting front $-\theta = k(v_r)$, it should be taken into account that input value for conductivity characteristics can be only positive ($v_r > 0$), so this restriction must be included in the identification of the infiltration regime.

10. Conclusions

As it may be concluded on the basis of the examples presented above, the course of the support process is quite complex and difficult to reflect using a simple solution of the general seepage equation, because it requires using an advanced program. The issue of hysteresis in different directions of moisture changes and at variable moisture values within the saturated zone should be taken into account in calculations. The results obtained using the simplified model, based on several standard analytical formulas, are sufficient in practical purposes. Despite significant schematization, they allow to estimate major values occurring after the support, such as the recharge level, capillary zone height, size of effective precipitation (runoff recharge), etc.

The article proposes a simple method for calculating the capillary rise in the presence of recharge from the vadose zone and hysteresis of moisture. It also analyzes the impact of support on the infiltration and presents the necessary modifications to the calculation using the principles of piston model.

References

- [1] Brooks R.H., Corey A.T., *Properties of porous media affecting fluid flow*, J. Irrigation and Drainage Div. ASCE '66/IR2, 61–88.
- [2] Kaluarachchi J.J., Parker J.C., *Effects of hysteresis with air entrapment on flow in the unsaturated zone*, Water Resour. Res. 23, 10, 1987, 1967–1976.
- [3] Książczyński K.W., *Calculation of actual evapotranspiration on vegetation-covered soils*, Technical Transactions, 1-Ś/2015, 53–60.
- [4] Książczyński K.W., *Tłokowy model filtracji w strefie niepełnego nasycenia (Piston model of seepage in the vadose zone)*, Monografia 353, Seria Inżynieria Środowiska, Wyd. PK, Kraków 2007, 188.
- [5] Richards L.A., *Capillary conduction of liquids through porous media*, Physics, 1, November 1931, 318–333.
- [6] Swartzendruber D., Clague F.R., *An inclusive infiltration equation for downward water entry into soil*, Water Resour. Res., 25, 4, 1989, 619–626.



