

FILIP LISOWSKI*

APPLICATION OF FINITE ELEMENT METHOD IN THE OPTIMAL DESIGN OF THE NUT WITH A GROOVE IN THE END-FACE

ZASTOSOWANIE METODY ELEMENTÓW SKOŃCZONYCH W OPTYMALNYM PROJEKTOWNIU NAKRĘTKI Z ROWKIEM W POWIERZCHNI CZOŁOWEJ

Abstract

The paper presents an application of finite element method in the optimal design of the nut with a groove in the end-face. There were described issues of the load distribution and FEM modeling of threaded connections. The optimization problem was formulated with the aim of obtaining the uniform load distribution on the bolt's thread depending on the geometry of nut.

Keywords: nut with a groove in the end-face, parametric optimization, finite element method

Streszczenie

W artykule przedstawiono zastosowanie metody elementów skończonych w optymalnym projektowaniu nakrętki z rowkiem w powierzchni czołowej. Opisano zagadnienia rozkładu obciążenia na gwincie w połączeniu śrubowym oraz modelowania MES połączeń gwintowych. Sformułowano zadanie optymalizacyjne, którego celem jest uzyskanie równomiernego rozkładu obciążenia na gwincie śruby w zależności od geometrii nakrętki.

Słowa kluczowe: nakrętka z rowkiem z powierzchni czołowej, optymalizacja parametryczna, metoda elementów skończonych

* MSc. Filip Lisowski, Institute of Machine Design, Faculty of Mechanical Engineering, Cracow University of Technology.

Denotations

$q(z)$	– expenditure of axial load in bolted joint [N]
F	– axial load in bolted joint [N]
m	– height of the thread [mm]
z	– coordinate of the thread height [mm]
k	– factor given by equation (2)
e	– factor given by equation (3)
C	– dimensionless coefficient dependent on the size of thread
σ_{HMH}	– Huber-Mises-Hencky reduced stress [MPa]
σ_{HMH}^{d2}	– Huber-Mises-Hencky reduced stress on $d2$ diameter [MPa]
$\Delta\sigma_{HMH}^{d2}$	– average standard deviation of σ_{HMH}^{d2}
σ_{HMH}^{d2ave}	– average Huber-Mises-Hencky reduced stress on $d2$ diameter for n cooperating coils of thread
C_{press}	– contact pressure on thread [MPa]
C_{press}^{all}	– allowable contact pressure for chosen material [MPa]
A_B, A_N	– cross-sectional areas of bolt and nut [mm ²]
E_B, E_N	– modulus of elasticity (Young modulus) of bolt and nut [MPa]
d	– outside diameter of bolt [mm]
$d2$	– average diameter of thread [mm]
Q	– objective function
pp_i	– design variables [mm]
n	– number of cooperating coils of thread
Re	– yield stress
Rm	– tensile strength

1. Introduction

Inspiration for this study was the report on durability analysis and variant optimization of the bolted joint Tr85×4 in the injection molder UT 440T. Researches were developed at Cracow University of Technology under the guidance of professor A.P. Zieliński. In the analyzed bolted joint the nut with supporting ring was applied. The aim of researches was to eliminate the cracking of a bolt at the first carrying coils of thread. The goal was achieved within the proper design of the nut and the supporting ring, which provided more uniform load distribution along bolt's thread.

Researches described in this paper consider the designing of the nut with a groove in the end-face subjected to the similar load conditions. The main advantages of such a nut are the uniform load distribution in axial direction and the reduction of the load on the most loaded coils of thread. The goal of the paper was to optimize the geometry of such a nut in order to obtain the uniform load distribution on the thread and therefore increase the fatigue strength of the bolt.

In the recent years some issues related to the fatigue failure, load distribution and bearing capacity of bolted joints were developed by: [1–4]. Some basic information about the nut with a groove in the end-face is also described in [5] and [6].

2. Load distribution on the thread

The nature of thread's load is complex. Axial force that tightens the screw causes bending and shear stresses in the bolt. Furthermore, contact pressure affects the thread's surface. This pressure can reach significant values even while the axial force is relatively small. Strength of the bolted joint depends on these loads. Stress concentration in the roots of thread can result in shearing the bolt. On the other hand, high contact pressure can hasten the wear of the thread surface. The analytical computational model of bolted connection based on the thin plate theory is presented in [7]. According to that model, for a typical bolted joint where the bolt is stretched and the nut is compressed, the load distribution along thread is described by equation (1).

$$q(z) = \frac{kF}{\sinh km} \cosh k(m-z) \quad (1)$$

$$k^2 = \frac{e}{C} \quad (2)$$

$$e = \frac{1}{E_B A_B} + \frac{1}{E_N A_N} \quad (3)$$

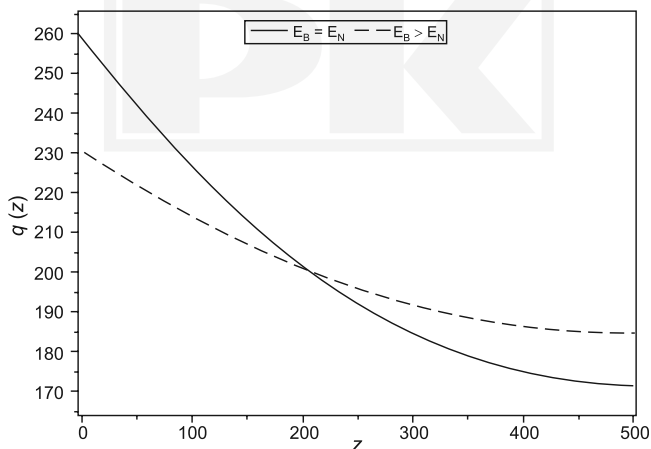

Fig. 1. Load distribution along the thread for $F = 100$ [kN], $C = 0,1$: a) $E_B = E_N = 2,11 \cdot 10^5$ [MPa],
b) $E_B = 2,11 \cdot 10^5$ [MPa], $E_N = 0,7 \cdot 10^5$ [MPa]

Rys. 1. Rozkład obciążenia na gwincie $F = 100$ [kN], $C = 0,1$: a) $E_B = E_N = 2,11 \cdot 10^5$ [MPa],
b) $E_B = 2,11 \cdot 10^5$ [MPa], $E_N = 0,7 \cdot 10^5$ [MPa]

3. Finite element model of bolted joint

In the numerical analysis of bolted connections the 3D model is usually simplified as 2D axisymmetric model. However, two contact forces, which are orthogonal to the axial direction, cannot be calculated from axisymmetric analysis, because they balance each other. To determine their values 3D analysis is required. Previous researches show that those two forces are only a small fraction of the total applied load and can be omitted for the load distribution analysis.

The helical effect on the load distribution was studied by [10] and also by [11]. It was concluded that the helix angle can be neglected therefore the axisymmetric model can give a good estimation of the load distribution. At the same it was shown that 2D model gives slightly higher values of loads than 3D model.

4. Optimization of the nut with a groove in the end-face

To perform the optimization problem 2D axisymmetric finite element model of the bolted joint Tr85×4 was built (Fig. 2). Plane82 elements available in ANSYS software were used. Between threads of the bolt and the nut contact elements Conta172 and Target169 were defined. The coefficient of friction in the plane of model was set to $\mu = 0.1$. The radius of the root of thread was modeled by proper size of finite element as described by [12] which resulted in a reduction of the optimization time. To the surface of the bolt's core the load $F=110$ [kN] was applied. Both for the bolt and the nut steel 42CrMo4 (EN 10083-1) with tensile strength $Rm = 1030$ [MPa], yield stress $Re = 880$ [MPa] and allowable contact pressure $C_{press}^{all} = 344$ [MPa] was chosen. Young modulus of the bolt and the nut $E_B = E_N = 2,11 \cdot 10^5$ [MPa] and Poisson ratio $\nu = 0.3$ were accepted. The geometry of a groove in the nut's end-face was parameterized as shown in Fig.3. Parametric optimization was performed by applying of ANSYS software as described by [13].

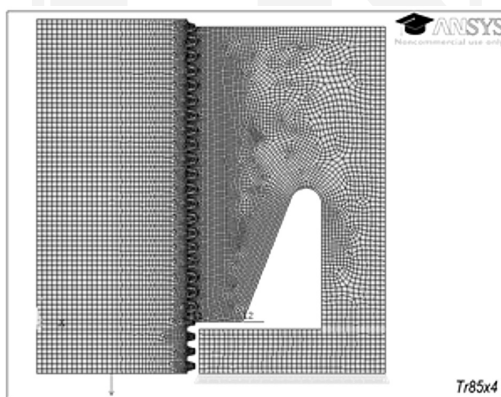

Fig. 2. Axisymmetric finite element model of bolted joint Tr85×4 with boundary conditions
Rys. 2. Osiowosymetryczny model MES połączenia śrubowego Tr85×4 z warunkami brzegowymi

4.1. Objective function

As an objective function average deviation of reduced stress on average diameter of bolted connection was accepted (eq. 4). Minimization of this function results in the more uniform load distribution and relieving the mostly loaded regions of thread.

$$Q(pp) = \Delta\sigma_{HMH}^{d2} = \sqrt{\frac{\sum_{i=1}^n (\sigma_{HMH_i}^{d2} - \sigma_{HMH}^{d2ave})^2}{n-1}} \quad (4)$$

$$Q(pp) \rightarrow \min \quad (5)$$

where:

- Q – objective function,
- $\Delta\sigma_{HMH}^{d2}$ – average standard deviation of σ_{HMH}^{d2} ,
- σ_{HMH}^{d2ave} – average Huber-Mises-Hencky reduced stress on diameter $d2$ for all cooperating coils of thread,
- n – number of cooperating coils of thread

4.2. Design variables and state variables

For the optimization process five of six parameters were chosen as design variables ($pp1$, $pp2$, $pp3$, $pp4$, $pp5$). Height of the nut was accepted due to respect the restriction of contact pressure and was accepted as constant for all starting points.

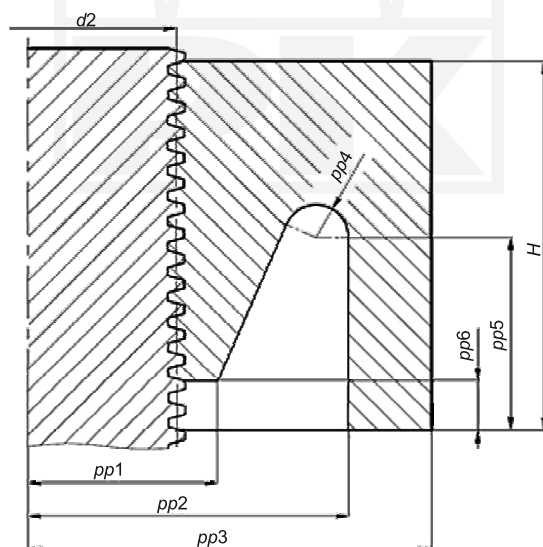

Fig. 3. Design variables and dimensions of the nut with a groove in the end-face
Rys. 3. Zmienne decyzyjne oraz wymiary nakrętki z rowkiem w powierzchni czołowej

Restrictions assumed for designed and state variables as well as starting points depending on bolt diameter summarized Table 1. The estimation of starting point's dimensions was partially based on the information included in [5] and drawings given by [9].

Table 1

Design and state variables with restrictions and optimization starting points

Design variables	<i>Sp1</i>	<i>Sp2</i>	<i>Sp3</i>	Restrictions
<i>pp1</i>	$0.65 \cdot d$	$0.65 \cdot d$	$0.65 \cdot d$	$d < pp1 < pp2 - pp$
<i>pp2</i>	$0.9 \cdot d$	$0.9 \cdot d$	$0.8 \cdot d$	$pp1 + 2 \cdot pp4 < pp2 < pp3$
<i>pp3</i>	$1.2 \cdot d$	$1.2 \cdot d$	$1.3 \cdot d$	$pp2 < pp3 < 1.6 \cdot d$
<i>pp4</i>	$0.05 \cdot d$	$0.05 \cdot d$	$0.1 \cdot d$	$0.05 \cdot d < pp4 < pp2 - pp1$
<i>pp5</i>	$0.4 \cdot d$	d	$0.7 \cdot d$	$0.4 \cdot d < pp5 < 0.9 \cdot H$
State variables				
<i>pp6</i>	$0.05 \cdot d$	$0.05 \cdot d$	$0.05 \cdot d$	–
<i>H</i>	$1.69 \cdot d$	$1.69 \cdot d$	$1.69 \cdot d$	–
C_{press}	–	–	–	$C_{press} < C_{press}^{all}$
σ_{HMH}	–	–	–	$\sigma_{HMH} < Re$

4.3. Results and discussion

In the Fig. 4 values of function Q resulted from optimization with starting points $Sp1$, $Sp2$, $Sp3$ were compared with values for the full nut and the reference nut with dimension of the groove proposed in [5].

Table 2

Design and state variables for the best optimization result (SP3)

<i>pp1</i>	$0.62 \cdot d$
<i>pp2</i>	$0.87 \cdot d$
<i>pp3</i>	$1.23 \cdot d$
<i>pp4</i>	$0.05 \cdot d$
<i>pp5</i>	$0.86 \cdot d$
<i>pp6</i>	$0.05 \cdot d$
<i>H</i>	$1.69 \cdot d$
C_{press}	297 MPa
σ_{HMH}	618 MPa
Q	4,1

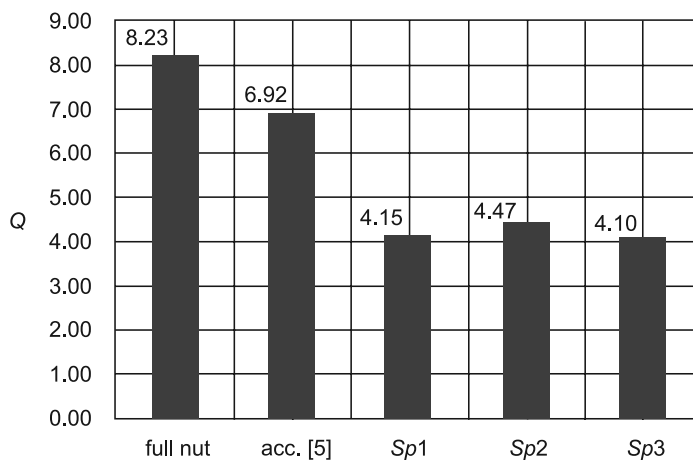

Fig. 4. Objective function after optimization with starting points in comparison with full and reference nut acc. [5]

Rys. 4. Funkcja Q po optymalizacji dla punktów startowych oraz nakrętki pełnej i odniesienia wg [5]

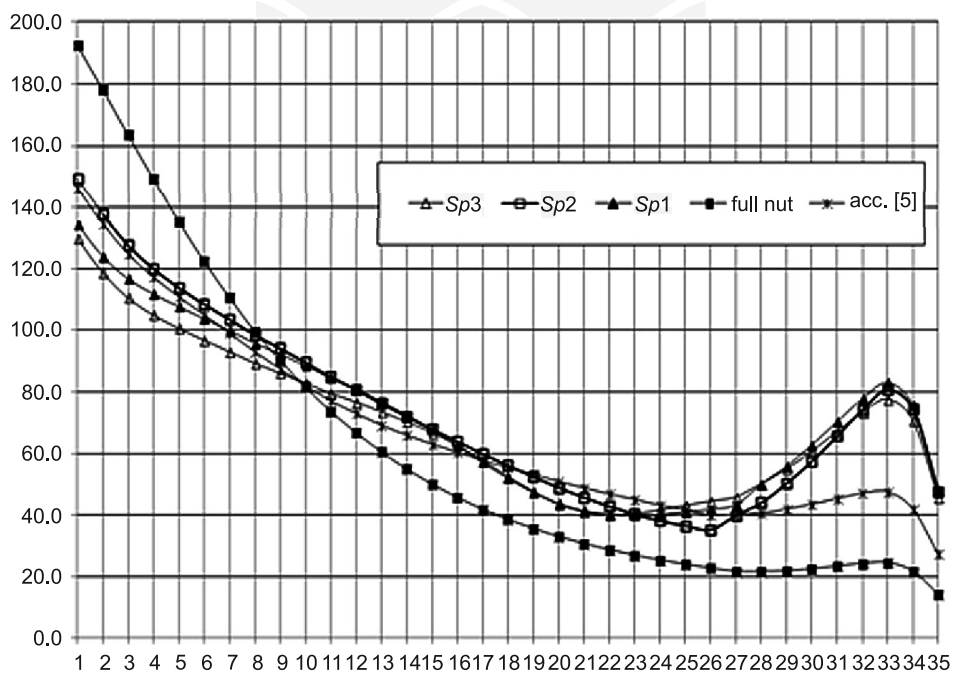

Fig. 5. Distribution of reduced stress σ_{HMH}^{d2} on coils of thread

Rys. 5. Rozkład obciążenia zredukowanego σ_{HMH}^{d2} na zwojach gwintu

The best result of optimization was obtained for starting point Sp_3 . Decrease of objective function in relation to the full nut was about 50%, decrease of maximum contact pressure 16% and decrease of the maximum of reduced stress about 61%. In comparison with the nut with a groove in the end-face according [5] decrease of objective function was close to 41%, decrease of maximum contact pressure 13% and decrease of maximum reduced stress about 9%.

5. Conclusions

Application of finite element method with optimization procedure in the designing of the nut with a groove in the end-face resulted in the improving of the load distribution in bolted joint and in the decreasing of maximum contact pressure on the thread. Presented approach shows that application of the optimization procedure in the designing of bolted joints allows to obtain significant improvement of the load distribution on thread and therefore can increase the fatigue strength of the bolt.

References

- [1] Libin Z., Fengrui L., Jianyu Z., *3D Numerical simulation and fatigue life prediction of high strength threaded bolt*, Key Engineering Materials, 2010, Vols. 417–418, 855-888.
- [2] Knes M., Glodź S., Kramberger J., *Fatigue assessment of piston rod threaded end*, Engineering Failure Analysis, Vol. 16, 2009, 1977-1982.
- [3] Honarmandi P., Zu J. W., Behdinin K., *Elasto–plastic fatigue life improvement of bolted joints and introducing FBI method*, Mechanics Based Design of Structures and Machines, Vol. 33, 2005, 311-330.
- [4] Pai N.G., Hess D.P., *Three–dimensional finite element analysis of threaded fasteners loosening due to dynamic shear load*, Engineering Failure Analysis, Vol. 9, 2002, 383-402.
- [5] Dobrovolsky K., Zablonksy S., Mak S., Radchik A., Erlikh L., *Machine Elements*, Mir Publishers, Moscow 1968.
- [6] Orłow P.I., *Osnovy konstruirowainja*, Maszinoctroenie, Moscow 1977.
- [7] Dietrich M., *Podstawy konstrukcji maszyn*, WNT, Warszawa 1995.
- [8] Skoć A., Spalek J., *Podstawy konstrukcji maszyn T.I*, WNT, Warszawa 2006.
- [9] Szewczyk K., *Połączenia gwintowe*, PWN, Warszawa 1991.
- [10] Chen J.-J., Shin Y.-S., *A study of the helical effect on the thread connection by three dimensional finite element analysis*, Nuclear Engineering and Design, Vol. 191, 1999, 109-116.
- [11] OHIO CAE INC., *Three-dimensional modeling of a bolted connection* (<http://www.ohiocae.com/bolt.htm>).
- [12] Lisowski F., *FEM modelling of structures with serial notches*, Czasopismo Techniczne, Politechnika Krakowska, 4M/2011/B, 2011, 341-348.
- [13] Stadnicki J., *Teoria i praktyka rozwiązywania zadań optymalizacji z przykładami zastosowań technicznych*, WNT, Warszawa 2006.