

PAWEŁ ŻWIREK\*

## SELECTED ISSUES OF STRUCTURE FORMING OF THE CONTEMPORARY SINGLE AND MULTI-CURVED ROOFS

### WYBRANE ZAGADNIENIA KSZTAŁTOWANIA KONSTRUKCJI WSPÓŁCZESNYCH DACHÓW JEDNO- I WIELOKRZYWIZNOWYCH

#### Abstract

In modern architecture, the roof function is not only to protect buildings against environmental influences. Designers often use single or multi-curved roofs. One of the issues to be considered at the structural design stage is selection of the support structure technology, thanks to which it will be possible to obtain a curved roof with a smooth surface. In case of objects such as airport terminals (eg., in Wrocław, Łódź, Rzeszów-Jasionka), sports and entertainment halls, conference centers (such as presently constructed in Kraków) and theme parks, mostly self-supporting metal panels are used (usually aluminum, about the length of one element up to tens of meters). The paper will present selected issues of forming the supporting structure of the multi-curved roofs made of self-supporting metal panels.

*Keywords: roof structure, metal cladding, multi-curved roof*

#### Streszczenie

We współczesnej architekturze dach przestał pełnić funkcję czysto techniczną sprowadzającą się jedynie do ochrony wnętrza budowli przed wpływami środowiskowymi. Projektanci obiektów często stosują dachy o postaci powierzchni jedno- lub wielokrzywiznowej. Jedną z kwestii, które należy rozważyć na etapie sporządzania projektu konstrukcji nośnej dachu, są rozwiązania techniczne, dzięki którym możliwe będzie uzyskanie gładkiej powierzchni zakrzywionej połąci dachowej. W przypadku takich obiektów jak terminale lotnicze (np. we Wrocławiu, Łodzi, Rzeszowie-Jasionce), hale widowiskowo-sportowe, centra konferencyjne (jak np. budowane obecnie w Krakowie), parki rozrywki stosowane są przeważnie samonośne panele metalowe – na ogół aluminiowe – o długości jednego elementu dochodzącej do kilkudziesięciu metrów. W artykule zostaną przedstawione wybrane zagadnienia kształtowania konstrukcji nośnej dachów wielokrzywiznowych z pokryciem wykonywanym z samonośnych paneli metalowych.

*Słowa kluczowe: konstrukcja dachu, pokrycie metalowe, dach wielokrzywiznowy*

\* Ph.D. Eng. Paweł Żwirek, Faculty of Civil Engineering, Cracow University of Technology.

## 1. Introduction

Roofs of buildings currently under construction, in addition to safe handling of loads acting on them and for protection of the interior of buildings against environmental influences, often become the “fifth façade” which confers a unique character of the building. A very dynamic development of CAD software supporting design work, allows creating detailed design documentation for objects with complex geometries. Roofs of modern airport terminals, sports and entertainment halls, stadiums and conference facilities often have roofs with a single- or multi-curved surface (see Ill. 1). The aesthetic appearance of the metal cover

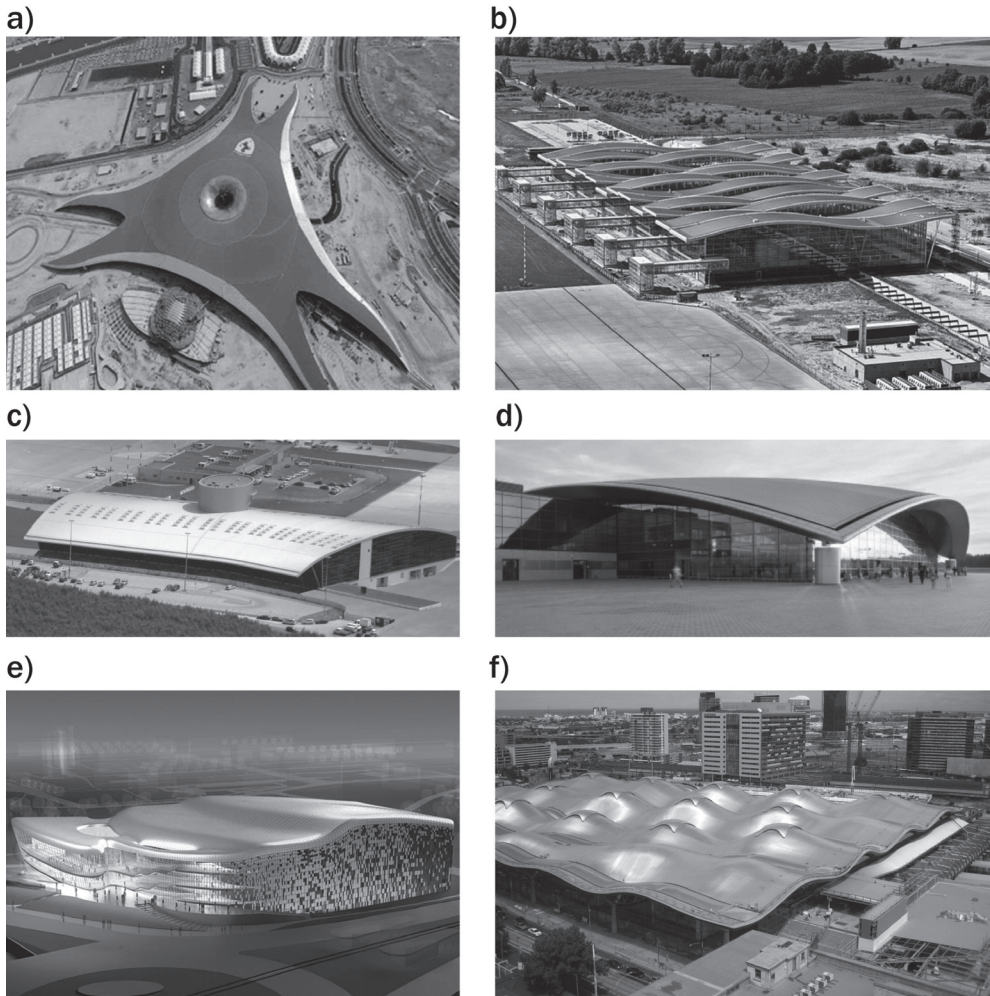

Ill. 1. Examples of roofs covered with self-supporting metal panels: a) Ferrari World Abu Dhabi [14], b) airport terminal in Wroclaw [18] c) airport terminal in Lodz [16], d) airport terminal in Rzeszow Jasionka [9], e) Convention Center in Krakow now under construction [11], f) Southern Cross Station Melbourne, Australia [17]

and the possibility of forming complex shapes while maintaining the integrity and durability, enable their wide use for these objects. Among the currently used types of metal roofing materials the most technologically advanced are self-supporting metal panels with a standing seam and carried out in accordance with the standards [3, 4, 6, 7]. This article will present selected issues of forming the supporting structure of the multi-curved roofs made of self-supporting metal panels.

Proper formation of the roof support structure, usually steel with complex geometry, requires knowledge of roof cladding systems with self-supporting metal panels. Currently there are a number of similar roofing systems of self-supporting metal panels on the market (e.g., [10, 12, 13]). The system consists mainly of metal panels produced on site from metal sheets (in coils) in a range of up to several tens of meters. For objects as shown in Ill. 1c and 1d, roof panels have a length equal to the distance between the drainage troughs located at the eaves on both sides of the roof. The panels are supported on brackets spot called clips (see Ill. 2).

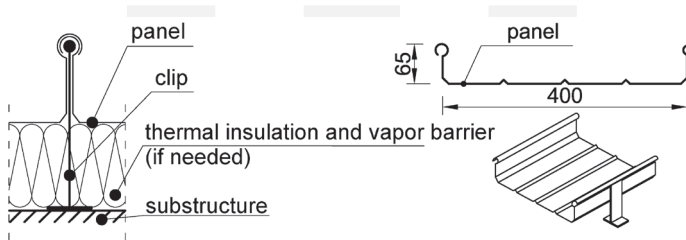

Ill. 2. Cover of the roof with self-supporting metal panels: components and sample shape of panel

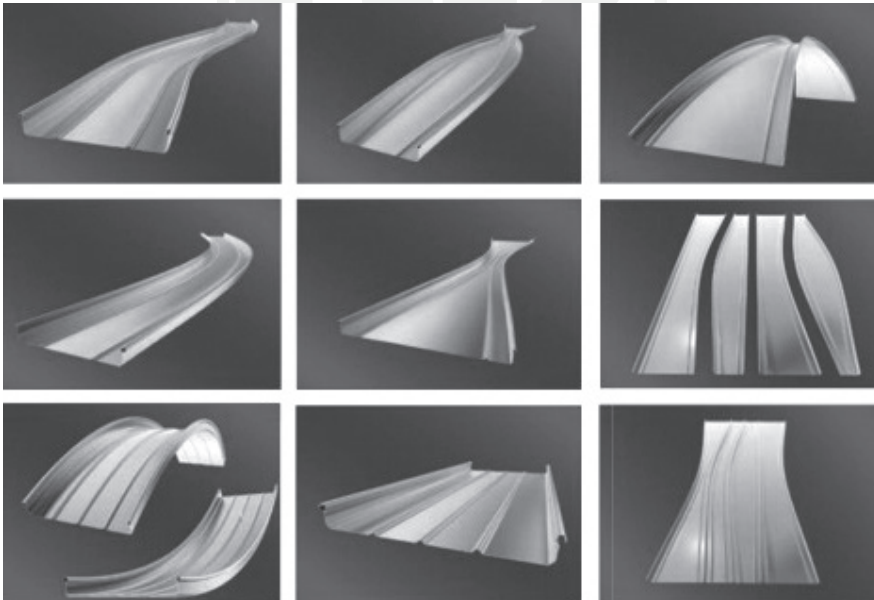

Ill. 3. Sample shapes of roof panels [10]

Description of the systems, methods of manufacturing and assembly of self-supporting roofing metal panels can be found in the paper [19]. Shapes of panels possible to produce (see Ill. 3) allow making airtight and aesthetic roofings even with very complex geometry.

## 2. Structural issues

Roofing panels only reproduce the shape that results from the location in the space grid points to which the clips are attached. Construction of clips does not allow for a smooth change of their length, therefore for proper shaping of the structure supporting the clips is of utmost importance to achieve the designed shape of the roof. The method for forming the roof structure is affected by: roof barrier layer system, the orientation of the panels in reference to the elements supporting the clips, roof shape. For single-curved roofs without thermal insulation, the simplest solution is to fix the design clips directly to the roof purlins arranged perpendicularly to the roof panels. During the design phase of construction it is important to match the spacing of purlins to the required spacing of clips. Allowable spacing of clips depends on the loads on the roof panels and the type of adopted panel (panel shape, type and thickness of the material). In the selection of clips' spacing, specialists in engineering departments of vendors and the information contained in such publications as [1, 2] might be helpful. Roof purlins should be designed so that their top flanges are aligned parallel to the tangent of the roof slope at rest point of the roof slope on the clip. For the present design solution roof beams can be both curved and piecewise linear (Ill. 4). The use of curved beams, purlins and panels of suitable shape makes it relatively easy to achieve a multi-curved roof.

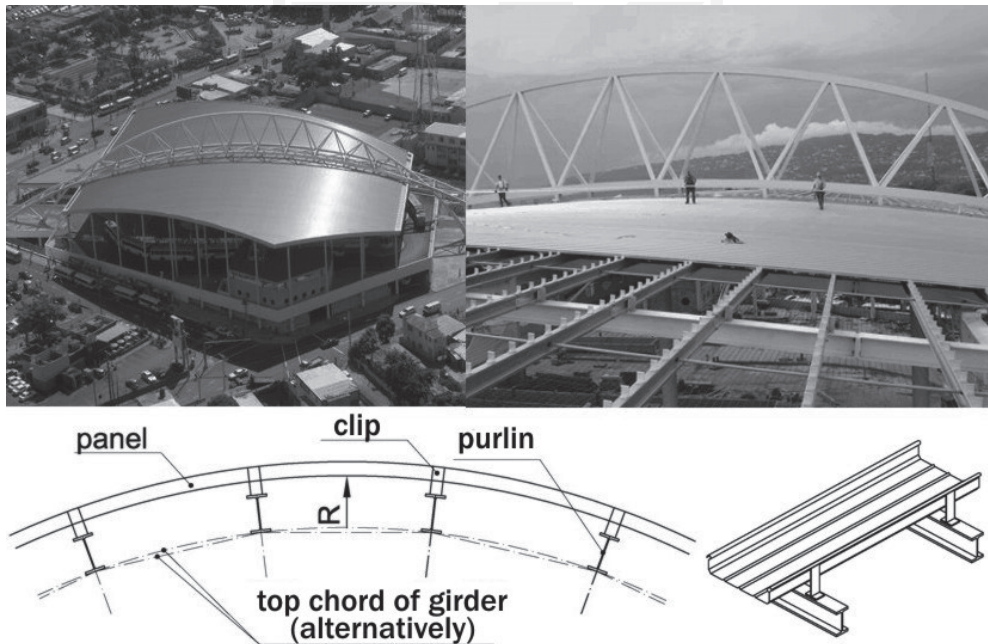

Ill. 4. Construction of the non-insulated single-curved roof

Non-insulated metal panel roofs may be used as so-called false roofs, which are used for higher visual aesthetics instead of the proper, sealed and insulated flat roof, along with the devices installed on the roof such as intakes, exhausts and air conditioning systems. These solutions were used in the currently constructed congress centre in Krakow.

If for economic or construction reasons it is required to use purlins with spacing greater than the allowable spacing of clips supporting the panels, trapezoidal sheets are used additionally. Trapezoidal sheets are also used in situations where directly under the roofing panels insulation is to be laid. In case of the roof shape as e.g., of the airport terminal in Wroclaw (see III. 1b, III. 5a), the roof structure consists of a suitably profiled girders and purlins. The purlins are covered with arch bent trapezoidal sheets. The use of arch bent trapezoidal sheets is generally economically feasible only for small differences due to the bending radius and the length of the number of types of sheets, which must be delivered to the construction site.

a)

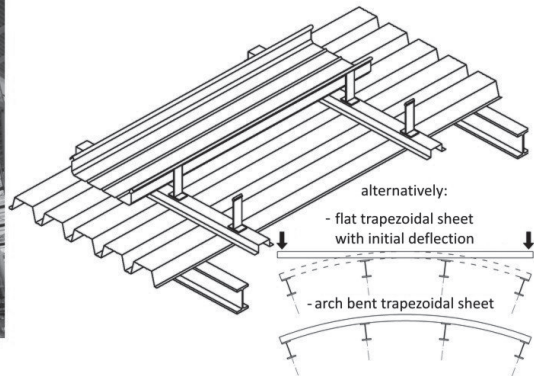
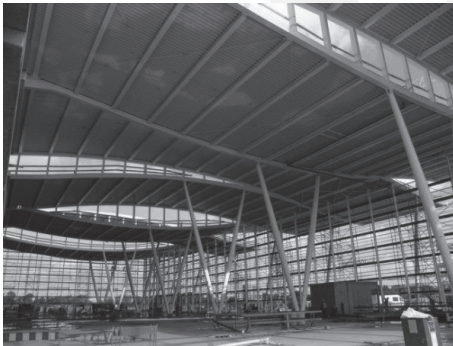

b)

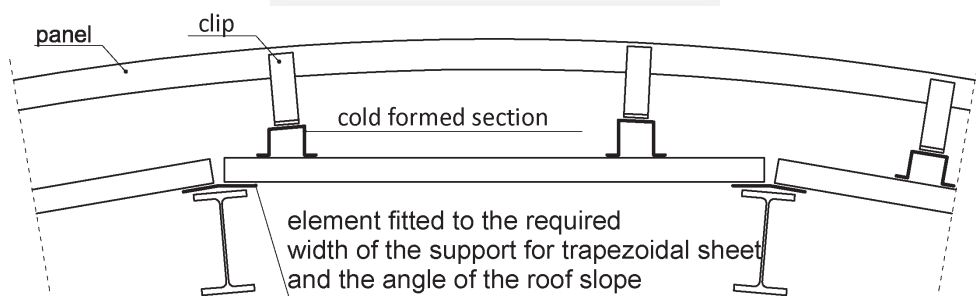

III. 5. Structure of single-curved insulated roof using: a) curved folded sheets, b) flat sheets

Due to the relatively small selection of arch bent trapezoidal profiles (compared to flat ones), flat trapezoidal sheets are used instead. Flat trapezoidal sheets are bent during assembly to the designed curvature of the roof (see III. 5a) set by location of e.g., roof purlins. The effect of initial deflection on the strength of the trapezoidal sheet can be significant and should be

taken into account when computing the static strength [5]. One should remember about the parallel to the tangent to the designed curve of arrangement of flanges of roof purlins. Roof panels are placed parallel to the folds of the sheet. The width of the roof panels is usually not a multiple of the width of the sheet folds, which prevents the assembly of clips directly to the trapezoidal sheet, as it can be in the case of the perpendicular arrangement of the panels and folds of the trapezoidal sheet (see Ill. 6). It is therefore necessary to introduce additional substructure. In the case of arch bent trapezoidal sheets or trapezoidal flat sheets with initial deflection, all the elements of the substructure may have the same shape. It is also possible to obtain a single-curved roof shape as in fig. 1b using a flat sheet without initial deflection. In such a situation purlins allowing for the proper support of the trapezoidal sheet should be designed as well as the substructure for clips of cold formed sections of suitable cross-sectional shape (see Ill. 5b). In the static strength calculation, one should consider the linear nature of the load of trapezoidal sheets by substructure supporting clips.

For single-curved roofs with insulation, one of the simplest design solutions is the use of the roof structure without purlins (see Ill. 6). The trapezoidal sheet is laid directly on the top chords of properly profiled roof girders. Roof panels run perpendicularly to the fold of the trapezoidal sheet. Axial spacing of clips is a multiple of axial spacing of the sheet folds. In the static strength calculations of the trapezoidal sheet, one should consider the nature of the load transferred from the roof panels to individual sheet folds. To avoid overloading a single fold sheet, clips of subsequent panels are moved along the standing seam of a sheet fold.

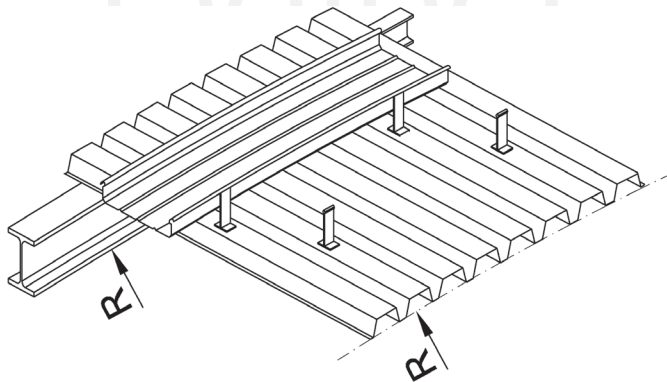

Ill. 6. Single-curved roof without purlins with trapezoidal sheet

For the roof as shown in Ill. 1d using only perpendicular or parallel position of panels regarding sheet folds is virtually impossible. Because of the variation in radius of curvature, the use of arch bent trapezoidal sheets can be economically unjustified. In this case, it is possible to use trapezoidal flat sheets. Individual folds of originally flat trapezoidal sheets are pre-bent, twisted or bent laterally or transversely deformed as a result of deliberate changes in the width of the folds [8]. Trapezoidal sheets are attached to a specifically shaped steel structure. Roof clips are attached to the substructure extending obliquely with respect to roof panels and sheet folds (see Ill. 7).

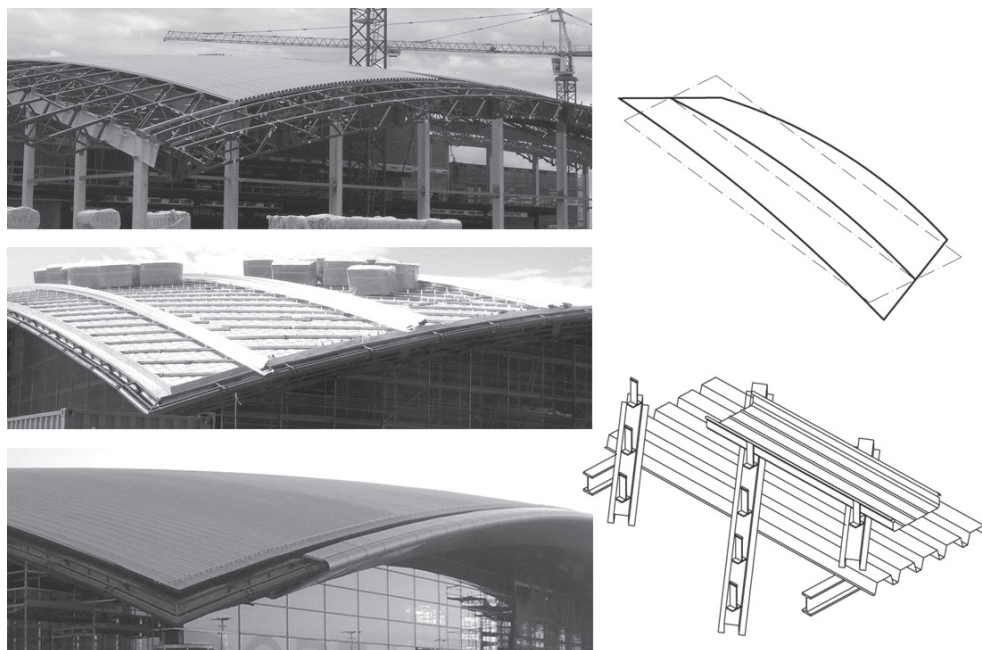

III. 7. The structure of two-curve roof [15]

Another of the most technologically advanced ways to achieve a roofing of complex shape, is to use special clips mounted on the rotating base installed on a curved section bar of the circular cross section (see Ill. 8). It is both possible to move and turn the clip relatively to the base of the profile. After determining the correct position, the base is stabilized by using mechanical fasteners. Thanks to this, the main support structure can be designed from simple straight elements, which only approximate the curvature of the roof. This solution makes full use of opportunities to develop roofings from panels of shapes as in Ill. 3. Installing the system requires constant surveying supervision.

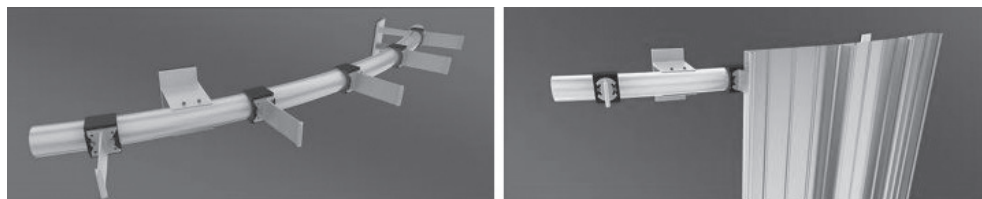

III. 8. Bemo-Dome system structure[10]

### 3. Conclusions

Possibilities of modern software supporting design work and technological advancement of carrying out roofing systems from self-supporting metal panels, allow

for making tight and aesthetic roofing even in the most complex geometry of the roof slope. At the stage of making technical and economic analyses in the selection of design solutions of roof systems, one must consider the requirements of self-supporting metal panels. Proper configuration of the supporting structure allows the realization of aesthetic and cheap solutions (Ill. 4).

#### References

- [1] Allgemeine Bauaufsichtliche Zulassung Z-14.1-181 Kalzip-Aluminium-Stehfalzprofil-Dach.
- [2] Allgemeine Bauaufsichtliche Zulassung Z-14.1-419 Aluminium-Stehfalzprofil-Dachelemente Falz-Ripp.
- [3] PN-EN 14782:2008 Samonośne blachy metalowe do pokryć dachowych, okładzin zewnętrznych i wewnętrznych. Charakterystyka wyrobu i wymagania.
- [4] PN-EN 508-1:2010 Wyroby do pokryć dachowych z metalu. Charakterystyka wyrobów samonośnych z blachy stalowej, aluminiowej lub ze stali odpornej na korozję. Część 1: Stal.
- [5] Pięciorak E., Żwirek P., *Wpływ wygięcia wstępnego na nośność blachy faldowej, Izolacje: budownictwo, przemysł, ekologia*, 11-12/2011.
- [6] PN-EN 508-2:2010 Wyroby do pokryć dachowych z metalu. Charakterystyka wyrobów samonośnych z blachy stalowej, aluminiowej lub ze stali odpornej na korozję. Część 2: Aluminium.
- [7] PN-EN 508-3:2010 Wyroby do pokryć dachowych z metalu. Charakterystyka wyrobów samonośnych z blachy stalowej, aluminiowej lub ze stali odpornej na korozję. Część 3: Stal odporna na korozję.
- [8] Reichhart A., *Analiza powłok z blach faldowych*, Nowoczesne Hale, 1/2011.
- [9] [www.apa.krakow.pl](http://www.apa.krakow.pl); access: 15.09.2013.
- [10] [www.bemo.com](http://www.bemo.com); access: 15.09.2013.
- [11] [www.iea.com.pl](http://www.iea.com.pl); access: 15.09.2013.
- [12] [www.interfalz.com](http://www.interfalz.com); access: 15.09.2013.
- [13] [www.kalzip.com.pl](http://www.kalzip.com.pl); access: 15.09.2013.
- [14] [www.meconstruct.be](http://www.meconstruct.be); access: 15.09.2013.
- [15] [www.me.com.pl](http://www.me.com.pl); access: 15.09.2013.
- [16] [www.rotwl.pl](http://www.rotwl.pl); access: 15.09.2013.
- [17] [www.trifixx.com.au](http://www.trifixx.com.au); access: 15.09.2013.
- [18] [www.wroclaw.naszemiasto.pl](http://www.wroclaw.naszemiasto.pl); access: 15.09.2013.
- [19] Żwirek P., *Wybrane zagadnienia projektowania dachów z pokryciem metalowym*, Czasopismo Techniczne, 2-A/1/2011.