

ANDRZEJ ZDZIARSKI\*

## OPTICAL TRANSFORMATION AND RECORDING OF ANAMORPHIC IMAGES

### OPTYCZNE PRZEKSZTAŁCENIE I ZAPIS OBRAZÓW ANAMORFICZNYCH

#### Abstract

The work presented here is a continuation of the earlier discussion undertaken by the author on the definition of geometric transformation and principles of creation and graphical representation of anamorphic images [3]. A specific method based on optics has been used to explain the method of creating complex geometrical anamorphic images with the inclusion of those parts of images that usually cover difficult deformations. The ideal scheme for an optical device which can be used for generating transformations of real life images into anamorphic images for this type of reflective anamorphic transformations has been developed. The validity and correctness of the geometrical and optical analysis of this type of transformation have been demonstrated in practice. A prototype of an optical device has been developed and used for the realization of this type of transformation and called the "Anamorphot". The image created using the Anamorphot proves validity of the theory of creation of anamorphic images as presented in earlier publications.

*Keywords: anamorphic images, anamorphic transformation, optic devices, ideal scheme*

#### Streszczenie

Obrazami anamorficznymi są płaskie, geometrycznie zdeformowane kompozycje celowo wykonane na dostępnych płaszczyznach. W przekształceniach tych zakłada się, że oglądu restytuowanych obrazów anamorficznych dokonuje się w odbiciu w określonej powierzchni refleksyjnej. Opracowanie w oparciu o wnikliwe analizy przekształceń anamorficznych wskazuje innowacyjną możliwość przekształcania obrazów rzeczywistych w obrazy anamorficzne oraz ich zapis. Określono schemat ideowy takiego urządzenia optycznego, które realizuje przekształcenie oraz zapis obrazów anamorficznych. Przedstawiono i opisano jego prototyp, wykazując jego praktyczną skuteczność, poprzez restytucję przekształconego i zapisanego optycznie obrazu anamorficznego.

*Słowa kluczowe: anamorfoza, przekształcenia anamorficzne, urządzenie optyczne, schemat ideowy*

DOI: 10.4467/2353737XCT.15.156.4193

\* Ph.D. Eng. Arch. Andrzej Zdziarski, Division of Descriptive Geometry, Technical Drawing & Engineering Graphics, Faculty of Architecture, Cracow University of Technology.

1. Geometrical principles of catoptric anamorphic transformation

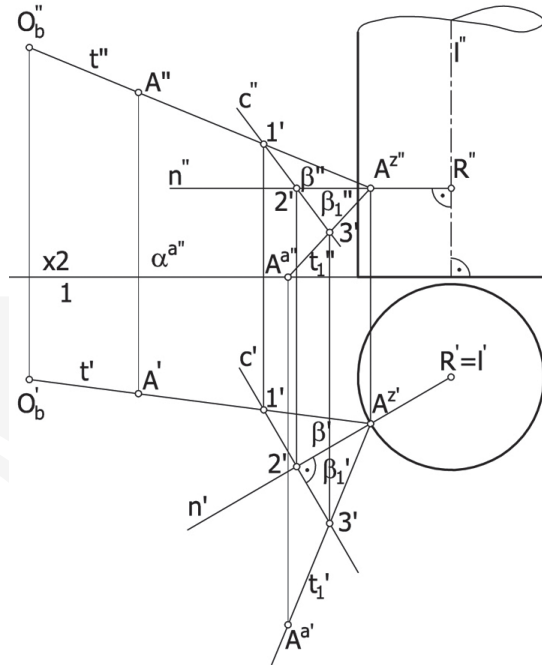

III. 1. Graphical notation of the anamorphic transformation of any point

III.1 describes the basic geometrical relations that exist between the elements of a 3D space and their images when projected in the reflexive anamorphic transformation with the use of a cylindrical reflexive surface. The geometric apparatus of the transformation contains the following elements: an anamorphic picture plane which is the plane ( $\alpha^a$ ), a reflexive surface of a cylinder of revolution with the axis ( $l$ ) perpendicular to the picture plane ( $\alpha^a$ ) and the centre of projection ( $O^b$ ) that belongs neither to the anamorphic picture plane ( $\alpha^a$ ) nor to the surface of the cylinder. The ray ( $t$ ) passing through any point ( $A$ ) of a 3D space and drawn from the centre of projection ( $O^b$ ), reflects at point ( $A^z$ ) on the reflexive cylindrical surface. According to the basic law of reflection, the angle of incidence ( $\varphi$ ) defined by the incident ray ( $t$ ) and the normal ( $n$ ) to the surface equals the angle of reflection ( $\varphi_1$ ) defined by the reflected ray ( $t_1$ ) and the same normal ( $n$ ). It has been proved that the two angles ( $\varphi$ ) and ( $\varphi_1$ ) are coplanar and thus the image ( $A^a$ ) of the point ( $A$ ) has been uniquely determined in the anamorphic picture plane ( $\alpha^a$ ) [7]. Due to the fact that the axis of the reflexive cylindrical surface is perpendicular to the anamorphic picture plane ( $\alpha^a$ ), the normal line ( $n$ ) has parallel position with reference to the plane ( $n \parallel \alpha^a$ ). We can conclude that the image of the angle of incidence ( $\beta'$ ) and the image of the reflection angle ( $\beta_1'$ ) are of equal measure ( $\beta' = \beta_1'$ ). This proves that the point ( $A^a$ ) as point of intersection of the reflected ray ( $t_1$ ) with the anamorphic picture plane ( $\alpha^a$ ) is the image of point ( $A$ ) in the anamorphic transformation as described above.

## 2. Logic diagram of the optical device for catoptric anamorphic image creation

It is worth noticing that in contemporary arts and architecture anamorphic images are becoming increasingly popular and artists have started to create such images today. The key point in understanding perspective anamorphic images is to remember that there is a double content hidden behind anamorphic images. On the one hand, we perceive the anamorphic images from the aesthetical viewpoint as works of art which create beautiful geometrical forms. On the other hand, anamorphic images are artistic compositions which, having been perceived from a specific viewpoint and at a specific angle of observation, reveal the true shape of the object hidden behind geometric deformations. The main point of the discussion provided in this paper is to show how it is possible to simplify the construction of the anamorphic images, specifically those which are characterized by highly complicated geometrical deformations.

Analysis of the geometric basics [6] as well as the dimensional relationships existing between the particular elements that create the base of the anamorphic transformation [5] together with the analysis of the potential solutions used by the optical industry has brought about the idea of producing a prototype of an optical device which might be used to produce anamorphic images from the deformed nets of anamorphic images. The goal was to be able to store the anamorphic images for future use.

Ill. 2A and 2B present schematic diagrams of the designed optical device together with a description of its principal elements. In Ill. 2A we can see the principle of construction of the device developed to produce reflexive anamorphic images with the use of a conical reflexive surface while Ill. 2B shows the device for cylindrical reflexive (or catoptric) anamorphic images.

The device as a whole has been closed in a hermetic box (4) which protects the interior from light inference. The movable part of the device consists of the lens “Biometar” (5) with a focal length of 120 mm. This part creates the core of the optical device. The lens has been placed in a tube which has been fixed to the camera box. The plate has been fixed to the camera’s box by a rotating joint at the bottom, and on the remaining part of the circumference by extensible bellows. The type of joints used to fix the lens inside the device enables freely adjustable tilt of its axis with reference to the both types of anamorphic picture planes (1 and 2). The incident rays are directed onto the reflexive surface, i.e. on the reflexive element (3). The correct tilt of the lens will be controlled by a special lamp which has been fixed between the plate of the box, the extensible bellows (7), and the box of a camera.

The movable elements of the camera also create: photographic plate holders for the horizontally or vertically positioned anamorphic picture planes (1, 2), reflexive elements (3), and masking frames (9). The photographic plate holder contains replaceable light-sensitive material (either light-sensitive paper or a plate) which will carry the stored anamorphic image.

The type of anamorphic picture plane decides on the type of anamorphic image. Reflexive anamorphic images of conical and pyramidal shapes will be recorded on the vertical picture plane (1) while for the reflexive conical and prismatic shapes the horizontal picture plane (2) will be used. The shape of the reflexive element can be developed for a number of various shapes which will be formed by variations and combinations of the basic forms.

A)

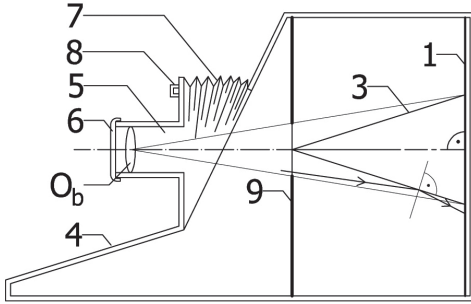

Optical device for conical reflexive anamorphic images

B)

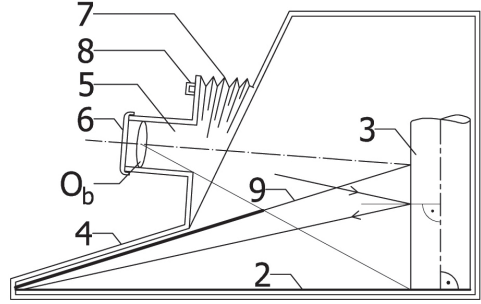

Optical device for cylindrical reflexive anamorphic images

III. 2. Ideal diagram of the optical device – cross-sections A) and B)

1. Vertically positioned photographic plate holder for the anamorphic picture plane;
2. Horizontally positioned photographic plate holder for the anamorphic picture plane;
3. Reflexive element (a cone or a cylinder dependent on the type of anamorphic image);
4. Hermetic box for the camera – blocking the light from interfering inside;
5. Lens of the optical device;
6. Cover of the lens;
7. Extensible bellows with lens that enables changing the inclination of the lens' axis;
8. A clamp that enables bellows' control;
9. Masking frame

a)

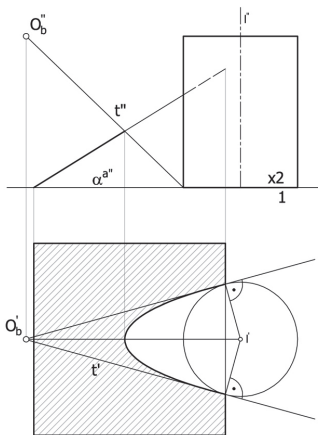

b)

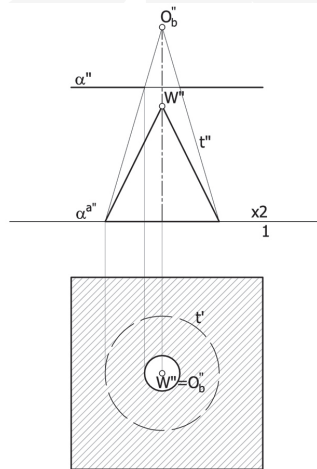

c)

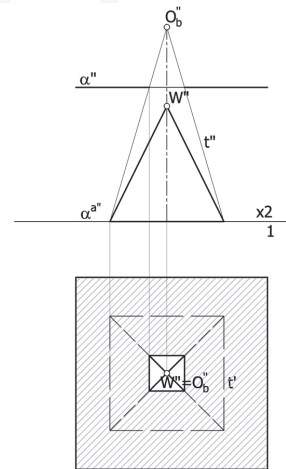

III. 3. Example shapes for the masking frames relative to various forms of reflexive elements: a) cylindrical, b) conical, c) pyramidal reflexive element

The masking frames (9) create the non-translucent partitions which block the access of the incident rays (t) to the anamorphic picture plane (1, 2) while simultaneously enabling access for the reflected rays. The shape of the masking frame will directly depend on the shape of the reflective element. Ill. 3 shows example shapes for the masking elements for the chosen reflexive anamorphic images: a) cylindrical, b) conical, c) pyramidal.

### 3. Prototype of the optical device “Anamorphot” used for anamorphic image creation

In the hermetic box a reflexive element in the shape of a cylinder of revolution has been fixed orthogonally to the light-sensitive anamorphic picture plane. The “Biometar” lens (5) has been positioned along the line of sight that passes through the centre ( $O_b$ ). The line of sight is the direction of observation in this case. The photographic plate holder has been designed to be adjustable to the usage either of standardized photographic paper or an X-ray plate ( $18 \times 24$  cm). The device is presented in Ill. 4.



Ill. 4. A prototype of the optical device “Anamorphot” (project development: A. Zdziarski)

The experiment was conducted over some span of time. In the first stage of the experiment, a focusing screen has been used instead of a photographic plate. This enabled us to take a peep at the created image and evaluate its size and clarity. As the parameters of the anamorphic picture plane do not change (are constant) in the optic device and as the centre of observation ( $O_b$ ) lies on the axis of the lenses, the range of the image to be transformed can be guided by choosing the relevant tilt of the lens axis. The maximum height of the anamorphic image which can be examined, is equal to the distance between the horizontal axis of the lens and the anamorphic picture plane [5].

Stiffening of the required position of the lenses axis will be carried out using a circular countering mechanism. In the prototype of the optical device no shutter was constructed due to technical conditions. Exposure to the light rays was realized by removing the lens cap, the exposure continued for a short time, then the cap was replaced.

An experiment was conducted using the “Anamorphot” device to demonstrate the validity of its construction. One of the first successful experiments was conducted on the example of a nut. An anamorphic image of the nut was created using the “Anamorphot” and then reconstructed in a reflexive surface of a cylindrical mirror.

The image taken on the horizontal photographic plate (2) has been chemically developed after taking a shot. Ill. 5 presents the distorted image of the nut. In the central part of the image we can see a distorted anamorphic picture of the nut on the background of the radial

grid of lines. In the top central part of the picture (Ill. 5) we can see a circular dark spot that determines the original position of a reflexive cylinder.

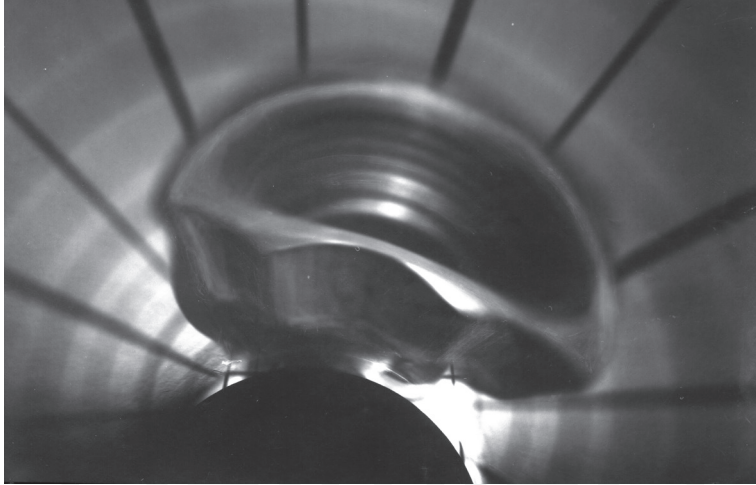

Ill. 5. Anamorphic transformation and photographic record of the nut obtained using the “Anamorphot” (photo by A. Zdziarski)

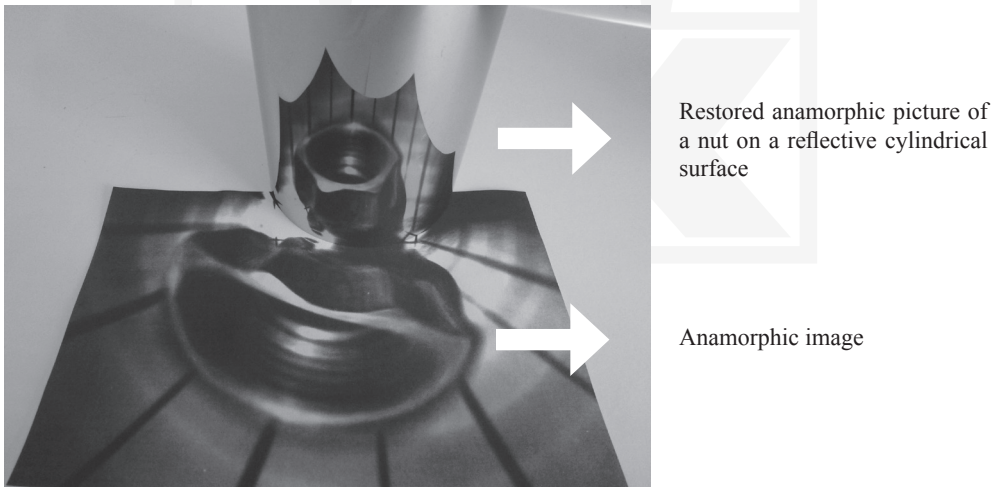

Ill. 6. Restoration of an anamorphic image of a nut (by A. Zdziarski)

The anamorphic image obtained by using the “Anamorphot” has been reconstructed and the result can be seen in Ill. 6. In the anamorphic picture plane a right circular cylinder has been positioned in such a way that its axis is perpendicular to the picture plane and the



cylinder's base was fixed within the dark circular trace at the top part of the image (aligned with the dark-shaded trace of the cylinder base). The image reflected in the cylindrical surface creates the shape of the nut as it is read from an appropriate direction. In the central part of the mirrored image we can see the non-deformed picture of the nut. The grid of radial lines turns out to be a background or a wallpaper for the picture.

In order to construct a conical anamorphic image of a nut we need to use a vertically positioned photographic plate holder and exchange the reflexive element for a conical one. Then we need to fix the conical reflexive element in a horizontal position so that the axis of the cone is perpendicular to the anamorphic picture plane and is co-axial with the lens' axis (Ill. 2A).

The transformation and recording of the anamorphic reflective images that were realized using the "Anamorphot" prototype demonstrate the validity of the device's construction. Specifically, the ability to obtain a correctly restored image of a nut by reflecting it in a cylindrical surface shows that the reasoning based on the basic law of reflection and based on the geometric principle of creation of anamorphic images is correct.

## References

- [1] Bartel K., *Perspektywa malarska (odbicia zwierciadlane)*, Vol. I, PWN, Warszawa 1960.
- [2] Bartel K., *Perspektywa malarska (mechaniczne i optyczne pomoce rysunkowe malarzy)*, Vol. II, PWN, Warszawa 1958.
- [3] Zdziarski A., *Anamorphic Transformation of Space Elements Aided with the Deformation Net*, Proc. 7<sup>th</sup> ICECGDG, Kraków 1996.
- [4] Zdziarski A., *Analiza geometryczna kształtująca parametry metryczne anamorfozy zwierciadlanej*, Lwów 2003.
- [5] Zdziarski A., *Podstawy powstawania rzutu anamorficzno-refleksyjnego*, Kielce 1980.
- [6] Zdziarski A., Pałka A., *Limacon of Pascal as an anamorphic image of a circle*, The Journal of Polish Society for Geometry and Engineering Graphics, Vol. 22, 2011, 3-6.
- [7] Leeman F., Elffers J., Schuyt M., *Hidden Images: Games of perception, anamorphic art, illusion*, Harry N. Abrams, Inc., New York 1976.
- [8] Baltrušaitis J., *Anamorfozy albo Thaumaturgus opticus: Deformation Nets for the Reflective Conical Anamorphoses*, Wydawnictwo słowo/obraz terytoria, Gdańsk 2009.
- [9] Du Breuil La Pere, *La perspective pratique*, Paris 1649.
- [10] Niceron J.-F., *La perspective curieuse ou magie artificielle des effets merveilleux*, Paris 1638.