

Grzegorz Filo (filo@mech.pk.edu.pl)

Institute of Applied Informatics, Faculty of Mechanical Engineering,
Cracow University of Technology

MODELLING OF A PNEUMATIC CUSHION IN MATLAB-SIMULINK SYSTEM

MODELOWANIE PODUSZKI PNEUMATYCZNEJ W SYSTEMIE MATLAB-SIMULINK

Abstract

The paper addresses modelling, simulation and experimental research of a pneumatic cushion. The scope of work included formulating a mathematical model based on air flow equations, building simulation model, carrying out simulations and comparing simulation results with experiments. The simulations were performed in Matlab-Simulink system, while experiments were carried out on a test bench, by means of a real industrial pneumatic cushion. The comparison of the results indicates that the created simulation model is accurate and flexible, and thus can be used in further research which concerns e.g. geometrical modifications or optimization of air consumption.

Keywords: pneumatic cushion, modelling, simulation, Matlab-Simulink

Streszczenie

Niniejszy artykuł dotyczy modelowania, symulacji oraz badań eksperymentalnych poduszki pneumatycznej. W zakres realizacji pracy weszło sformułowanie modelu matematycznego w oparciu o równania przepływu powietrza, budowa modelu symulacyjnego, przeprowadzenie symulacji oraz porównanie ich wyników z badaniami eksperymentalnymi. Badania symulacyjne wykonano w środowisku Matlab-Simulink, natomiast eksperymenty zostały przeprowadzone na stanowisku badawczym z wykorzystaniem rzeczywistej przemysłowej poduszki pneumatycznej. Porównanie uzyskanych wyników wskazuje, że zbudowany model jest dokładny i elastyczny, a zatem może być używany w przyszłych badaniach dotyczących np. zmian konstrukcyjnych lub optymalizacji zużycia powietrza.

Słowa kluczowe: poduszka pneumatyczna, modelowanie, symulacja, Matlab-Simulink

Denotations

- i – chamber index, respectively: 1 – inlet, 2 – side chamber, 3 – bottom chamber,
 $m_i = dm_i/dt$ – mass air flow [kg/s],
 V_i, T_i, p_i – parameters of i^{th} chamber: volume [m³], temperature [K], pressure [Pa],
 R, κ – gas constant of air [J/(kg K)], heat capacity ratio [–],
 M – mass of a cushion load [kg],
 z_s, z_f – vertical displacement of the side chamber and width of the air gap [mm],
 z – total vertical displacement of the cushion [mm],
 F_a, F_g, F_s – force from air pressure in the side chamber, force of gravity, force of elasticity of side chamber walls [N],
 A_2 – contact area between a bellow and a substrate [m²],
 R_o, R_i – outer and inner radius of the contact area between a bellow and a substrate [m],
 a_3, a_2, a_1, a_0 – coefficients [–],
 d_1, d_2 – diameters of nozzles [m²],
 ψ – flow coefficient of nozzles [–].

1. Introduction

Pneumatic cushions are presently more and more often used in the construction of indoor transport systems inside halls or warehouses. Particularly, in industrial companies there is a continuous need to move heavy loads, such as machine tools, semi-products, components, etc. Usually, various types of lifting devices (cranes, winches, forklifts) are used for this purpose. In most cases, the devices fulfill their task properly; however, large sizes may prevent their use inside industrial buildings. On the other hand, industrial buildings are now constructed using modern technologies, providing horizontal and smooth work surfaces, including the inclination angle α not exceeding 0.1° and surface roughness R_a less than $25 \mu\text{m}$. Fulfillment of the conditions allows for the introduction of transport systems on pneumatic cushions. The cushions are small and light devices. Particularly useful is their low height of 30–40 mm, which is stated in [1, 2]. Simple and compact design allows the operator to put the cushions under the load quickly and easily.

Earlier work of the author of this article included automation of the pneumatic cushion transport system in order to obtain the required pressure course [3] and vertical displacement [4]. This paper presents the mathematical model of a pneumatic cushion with a load, which is the base for a simulation model built in Matlab-Simulink. The simulation model was used to carry out studies on pneumatic cushion characteristics, which were then compared with the results obtained on a test bench for a real cushion.

2. Working principle of a pneumatic cushion

The primary function of a pneumatic cushion is the displacement of a load after lifting it vertically to a small height of about 15–25 mm. Vertical lifting is caused by pressure increase in the rubber bellow, while the displacement is a result of a horizontal force usually generated by the operator. Air flow between the bottom surface of the cushion and the floor forms a gap which reduces friction to a very low value (friction coefficient less than 0.001). Hence, movement of even heavy objects can be easily accomplished.

2.1. Object of study

A pneumatic cushion, whose view is shown in Fig. 1 and cross-sectional schematic diagram is presented in Fig. 2, is the object of the study. The mathematical model includes flow balances of individual volumes V_2, V_3 , flow equations through nozzles Q_2, Q_3 , equations defining adiabatic process and equations of motion. The resulting values are an air gap width z_j and a total lifting height of the cushion z_1 .

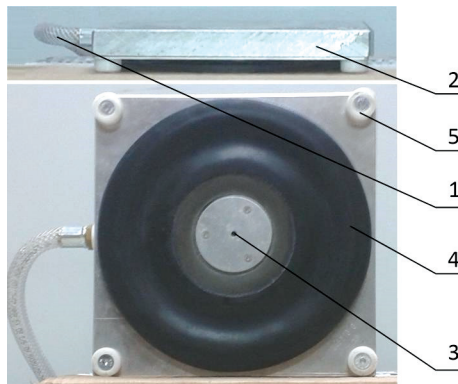

Fig. 1. The studied pneumatic cushion: 1 – inlet hose, 2 – bearing plate, 3 – outlet nozzle, 4 – rubber bellow, 5 – landing pad

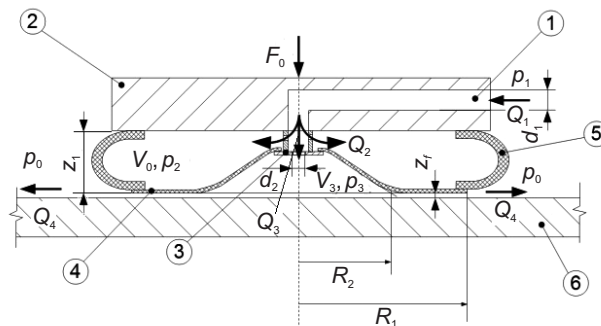

Fig. 2. Cross-sectional diagram of the cushion: 1 – inlet channel, 2 – bearing plate, 3 – outlet nozzle, 4 – bearing surface of a bellow, 5 – side surface of a bellow, 6 – substrate

2.2. Mathematical model

The mass flow rate of air at the inlet of a pneumatic cushion is determined based on the equation of continuity, assuming homogeneity of a gas stream [6]. The inlet stream \dot{m}_1 is divided into a side chamber stream \dot{m}_2 and a bottom stream \dot{m}_3 . From the mass conservation law:

$$\dot{m}_1 = \dot{m}_2 + \dot{m}_3 \quad (1)$$

A side chamber stream \dot{m}_2 is modelled as filling a reservoir of a variable volume. This process can be described by a non-linear differential equation of the first order [6]:

$$V_2(t) \cdot \frac{dp_2(t)}{dt} + \kappa \cdot p_2(t) \cdot \frac{dV_2(t)}{dt} = \kappa \cdot R \cdot T_1 \cdot \frac{dm_2(t)}{dt} \quad (2)$$

Transformation of equation (2) leads to the formula which allows for the determination of the side chamber volume as a function of time:

$$\frac{dV_2(t)}{dt} = \frac{R \cdot T_1}{p_2(t)} \cdot \frac{dm_2(t)}{dt} - \frac{V_2(t)}{\kappa \cdot p_2(t)} \cdot \frac{dp_2(t)}{dt} \quad (3)$$

Equation of vertical lift of the pneumatic cushion caused by filling the side chamber can be determined from the following force balance:

$$M \frac{d^2 z_1(t)}{dt^2} = F_a - F_g - F_s - F_{pt} \quad (4)$$

where the individual forces are calculated using the following equations (5)–(8). Force from the air pressure can be calculated as:

$$F_a(t) = p_2(t) \cdot A_2(t) \quad (5)$$

while force of gravity:

$$F_g = M \cdot g \quad (6)$$

The force of elastic bellow material is estimated using a polynomial approximation on the basis of the laboratory test results:

$$F_s(z_1) = a_3 \cdot z_1^3 + a_2 \cdot z_1^2 + a_1 \cdot z_1 + a_0 \quad (7)$$

and the force resulting from the thermodynamic process, assuming the adiabatic change (negligible heat exchange between the air inside and outside of the chamber) is described by the following equation [6]:

$$F_{pt}(t) = K \cdot [V_2(0) + A_2 \cdot z_1(t)]^{-\kappa} \quad (8)$$

where K is a coefficient calculated on the basis of the initial conditions:

$$K = A_2 \cdot p_2(0) \cdot [V_2(0)]^k \quad (9)$$

Air stream flowing into the bottom chamber $\dot{m}_3(t)$ through a nozzle of a diameter d_2 is determined with regard to the critical velocity. Air velocity depends on the pressure ratio $\beta = p_3/p_1$. In the case of the adiabatic change, the coefficient is constant: $\beta = 0.53$ [7]. If $p_3/p_1 \leq \beta$, the supercritical flow with the sonic velocity occurs, otherwise the velocity is lower. Thus, the theoretical mass inflow to the bottom chamber is as follows:

$$\frac{dm_3(t)}{dt} = \frac{\pi \cdot d_2^2}{4} \cdot p_1(t) \cdot \sqrt{\frac{2}{R \cdot T_1}} \cdot \Psi(t) \quad (10)$$

where $\Psi(t)$ depends on pressure values:

$$\Psi(t) = \sqrt{\frac{\kappa}{\kappa-1} \left[\left(\frac{p_3(t)}{p_1(t)} \right)^{2/\kappa} - \left(\frac{p_3(t)}{p_1(t)} \right)^{(\kappa+1)/\kappa} \right]} \quad (11)$$

In the case of the supercritical flow Ψ is constant: $\Psi_{kr} = 0.684$, hence the equation (10) can be simplified to:

$$\frac{dm_3(t)}{dt} = 0.7594 \cdot \frac{d_2^2 \cdot p_1(t)}{\sqrt{R \cdot T_1}} \quad (12)$$

Pressure in the bottom chamber $p_3(t)$ may be calculated from the flow balance [3]. When p_3 raises enough to compensate the load force, an air gap appears between the bottom surface of the bellow and the substrate. Vertical movement which creates the z_f gap results from the balance between the lifting force F_0 and the force of gravity F_g :

$$M \frac{d^2 z_f(t)}{dt^2} = F_0 - F_g \quad (13)$$

F_0 depends on pressure and contact area between the cushion and the substrate [5]:

$$F_0(t) = \frac{\pi \cdot p_3(t) \cdot (R_1^2 - R_2^2)}{2 \cdot \ln(R_1 / R_2)} \quad (14)$$

Sum of z_1 (4) and z_f (13) is the total vertical displacement: $z(t) = z_1(t) + z_f(t)$.

2.3. Simulation model

The simulation model of a pneumatic cushion created in Matlab-Simulink by implementing system of equations (1) to (14) is shown in Fig. 3.

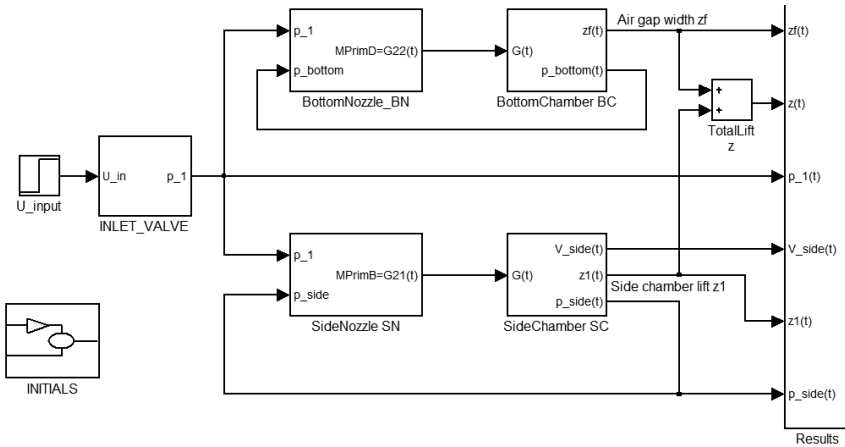

Fig. 3. Simulation model in the form of a Matlab-Simulink block diagram

The main components of the model represent proportional relief valve INLET_VALVE, two nozzles leading to the SN side chamber and the BN bottom chamber, and the same SC and BC chambers. Input signal in the form of a step function is generated by the U_input block. Other blocks are used to set the initial values and acquire the simulation results.

3. Plan and results of experiments

The simulations included the determination of the $z_f(t)$ width gap and $z(t)$ total vertical displacement depending on the load and the inlet pressure. The following values of the load were tested: from $M_1 = 50$ kg to $M_5 = 250$ kg every $\Delta M = 50$ kg. Similarly, the inlet pressure was from $p_{1,1} = 0.15$ MPa to $p_{1,5} = 0.20$ MPa every $\Delta p_1 = 0.01$ MPa. Example results of $z(t)$ and $z_f(t)$ obtained for $p_{1,5} = 0.20$ MPa and selected load values are presented in Fig. 4a and Fig. 4b, respectively.

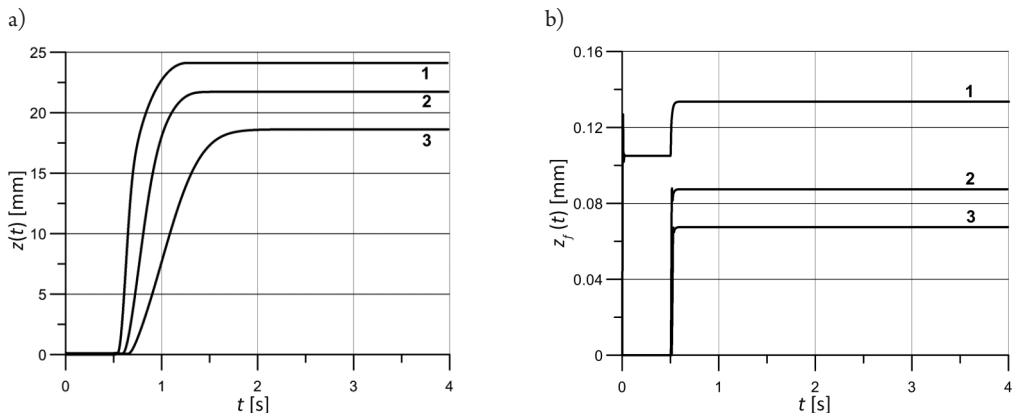

Fig. 4. Simulation results for $p_1 = 0.2$ MPa: a) total lift height $z(t)$, b) air gap width $z_f(t)$. Mass of the load: 1 – $M = 50$ kg, 2 – $M = 150$ kg, 3 – $M = 250$ kg

Figure 5 shows a collective summary of the simulation results in the form of a 3D surface. The simulation results indicate that in response to the step function of the input pressure, in each case an asymptotic equilibrium position has been obtained. No pulses at the startup or in the steady state were observed. Total vertical displacement of the z cushion varied from 13.1 mm to 22.2 mm for $p_1 = 0.15$ MPa and from 18.6 mm to 24.1 mm for $p_1 = 0.20$ MPa, depending on the load. The air gap width in these cases varied respectively from 60.9 μm to 129.0 μm and from 67.5 μm to 133.6 μm .

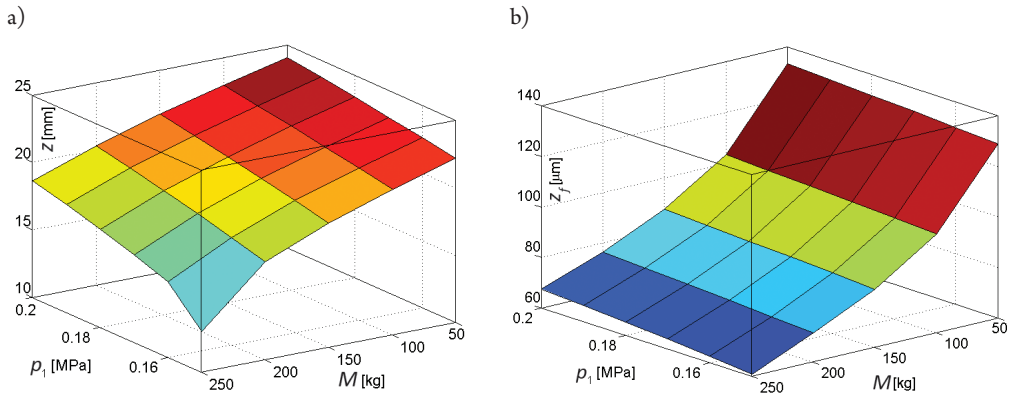

Fig. 5. Total lift height z and air gap width z_j against inlet pressure p_1 and load M

The simulation results were compared with the results of stand tests conducted using a real pneumatic cushion. Exemplary comparison of the results obtained for the inlet pressure $p_1 = 0.20$ MPa and the load $M = M_1 = 50$ kg and $M = M_5 = 250$ kg are shown in Fig. 6. The comparison showed high compliance level, since the maximum relative error in the steady state is less than 5% for the $M = 250$ kg, and approximately 1% for $M = 50$ kg.

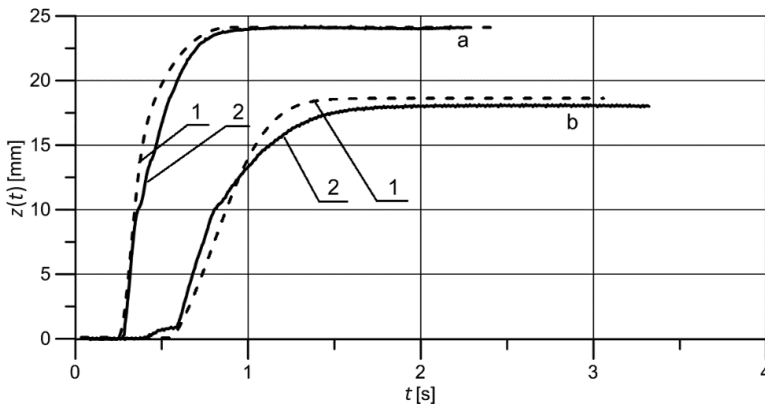

Fig. 6. Comparison of simulation (1) and laboratory (2) results for $p_1 = 0.20$ MPa; mass of the load: a) $M = 50$ kg, b) $M = 250$ kg

4. Summary

This work applies to modelling and examining of operational characteristics of a pneumatic cushion. First, a mathematical model was built in the form of set of differential equations. Then the model has been implemented in Matlab-Simulink. Simulation studies were carried out for different values of the inlet pressure and the load. The results of simulation studies were compared with those obtained from the laboratory experiments. A satisfactory compliance has been obtained, which proves correctness of the model and research assumptions. The created model will be used in further research in order to improve stability and reduce air consumptions of pneumatic cushions.

References

- [1] Bullard L., *Hovercraft*, Lerner Publications Company, Minneapolis, USA, 2007.
- [2] Yun L., Bliault A., *Theory and Design of Air Cushion Craft*, Butterworth-Heinemann, United Kingdom, 2000.
- [3] Lisowski E., Filo G., *Pressure control in air cushions of the mobile platform*, Journal of KONES Powertrain and Transport, Vol. 18, No. 2, Warsaw 2011, 261–270.
- [4] Lisowski E., Filo G., *Automated heavy load lifting and moving system using pneumatic cushions*, Automation in Construction 50, 2015, 91–101.
- [5] Lisowski E., Kwiatkowski D., *Określenie podstawowych parametrów systemu pneumatycznego platformy transportowej na poduszkach pneumatycznych*, Przegląd Mechaniczny, no. 2/12, Warszawa 2012, 45–48.
- [6] Wołkow J., Dindorf R., *Teoria i obliczenia układów pneumatycznych*, Wydawnictwo Politechniki Krakowskiej, Kraków 1994.
- [7] Szenajch W., *Napęd i sterowanie pneumatyczne*, WNT, Warszawa 2003.