

KATARZYNA RZESZUT*, MACIEJ SZUMIGAŁA*, ŁUKASZ POLUS*

SELECTED ASPECTS OF THE PROPER APPLICATION OF STRUCTURAL MATERIALS IN TERMS OF CORROSION

WYBRANE ASPEKTY POPRAWNEGO STOSOWANIA MATERIAŁÓW KONSTRUKCYJNYCH W WARUNKACH KOROZJI

Abstract

In this paper, the problem of corrosion in structural elements made of materials which are considered as corrosion resistant is discussed. The paper presents an analysis of the reasons for corrosion damage to structural elements used in civil engineering. The main aim of the work was to identify the potential causes of corrosion and to formulate recommendations that allow the selection of the best structural material properties in order to counteract the negative impact of the corrosive environment. For this purpose, stainless steel ventilation duct corrosion in an indoor swimming pool hall is analysed. An assessment of the nature of the reasons for the potential damage of ventilation ducts is performed based on macroscopic inspection. This allowed the determination of the type and nature of the existing corrosion of stainless steel. The analysis of the results of the chemical composition of the material provided by the gravimetric method and the results of the corrosion products report provided further information. Based on its conclusions, recommendations in order to avoid this type of corrosion in aggressive indoor swimming pool environments are formulated. Next, the problem of corrosion of aluminium in contact with steel in new aluminium and concrete composite structures which consist of an aluminium beam, steel trapezoidal sheeting and a concrete slab is analysed. Moreover, recommendations in order to avoid this type of corrosion are formulated. The presented analyses can be a valuable source of information on corrosion and protection methods in specific cases of building structures.

Keywords: stainless steel, aluminium, aluminium and concrete composite structures

Streszczenie

W artykule poruszono problem korozji w elementach konstrukcyjnych wykonanych z materiałów uznawanych za odporne na korozję. Artykuł zawiera analizę przyczyn niszczenia elementów konstrukcyjnych wskutek korozji. Główny cel pracy to określenie potencjalnych przyczyn korozji i sformułowanie zaleceń, które pozwolą wybrać najlepsze właściwości materiału w celu przeciwdziałania korozyjnemu środowisku. W tym celu poddano analizie skorodowane przewody wentylacyjne zamontowane w krytej pływalni. Ocena charakteru potencjalnych przyczyn uszkodzeń kanałów wentylacyjnych była wykonana w oparciu o badania makroskopowe. To pozwoliło określić typ i naturę korozji w stali nierdzewnej. Analiza składu chemicznego materiału otrzymana z badania metodą grawimetryczną oraz wyniki raportu o produktach korozji dostarczyły dodatkowych informacji. W oparciu o powyższe sformulowano wnioski i zalecenia, w jaki sposób uniknąć tego typu korozji w agresywnym środowisku występującym w krytej pływalni. Następnie przeanalizowano problem korozji aluminium w kontakcie ze stalą w nowych aluminiowo-betonowych konstrukcjach zespolonych, które składają się z: aluminiowej belki, stalowej trapezowej blachy i betonowej płyty. Ponadto sformulowano zalecenia, w jaki sposób uniknąć korozji w tych konstrukcjach. Zaprezentowane analizy mogą być cennym źródłem informacji na temat korozji i metod jej zapobiegania w konkretnych budynkach.

Słowa kluczowe: stal nierdzewna, aluminium, aluminiowo-betonowe konstrukcje zespolone

DOI: 10.4467/2353737XCT.15.082.3882

* Ph.D. Katarzyna Rzeszut, D.Sc. Ph.D. Maciej Szumigała, M.Sc. Łukasz Polus, Institute of Structural Engineering, Faculty of Civil Engineering and Environmental Engineering, Poznan University of Technology.

1. Introduction

Stainless steels and aluminium are widely used in civil engineering applications. Stainless steels cover a wide range of steel types and grades which characterise high resistance against corrosion or oxidation [10]. Stainless steels are iron alloys with a minimum of 10.5% chromium and with other alloying elements such as nickel, molybdenum, titanium, copper and carbon. These alloying elements enhance the properties of the material, the most important being its strength and corrosion resistance. The influence of chemical composition and temperature on the physical properties of austenitic stainless steel is presented in [2]. The present paper discusses the temperature influence on mechanical properties, such as tensile strength, fatigue and creep. Mechanisms to strengthen the austenitic stainless steels by appropriate thermo-mechanical treatments are analysed and the fact that the selection of a particular grade of stainless steel must meet the corrosion resistance requirements for a specified application or environment is highlighted. The problem of stainless steel corrosion is widely discussed in literature. The uniform corrosion aspect of austenitic stainless steels in various corrosive environments is reviewed in [12]. Ningshen and Kamachi Mudali discussed the application of existing and advanced austenitic alloys for various chemical media and the various testing techniques employed for assessing uniform corrosion. The pitting corrosion of austenitic stainless steels is studied in [7], this takes into account the influence of alloy composition, microstructure, cold working, grain size and different parameters of environments. The susceptibility of annealed and unannealed AISI 444 ferritic stainless steel to pitting and crevice corrosion is analysed in [1]. It was found that annealing does not improve the resistance to pitting and crevice corrosion. The problem of stainless steel corrosions became most important in the case of application in indoor swimming pool buildings. Highly aggressive conditions result from the particular atmospheric circumstances in such buildings and this decreases corrosion resistance. Common reasons for stainless steel corrosion in indoor pools are presented in [4]. Houska and Fritz pointed out that chlorine-based chemicals used to disinfect pool water produce chloramines which are passed into the atmosphere and deposited on metal surfaces causing the corrosion problems. The corrosion rate varies with temperature and humidity level and may result in the damage of swimming pool equipment or main structural element collapse. It was found that usually, collapses are caused by stress corrosion cracking (SCC) of stainless steel load bearing elements subjected to tensile stress. According the European Standard recommendations [15], several austenitic steels are suitable for many applications in indoor and outdoor swimming-pools. The investigation conducted in [5] confirms that stainless steel 1.4547 shows the best performance and resistance to stress corrosion cracking compared to the other tested stainless steels. Nevertheless, even this kind of stainless steel can be susceptible to SCC if deposits of chloride salts and very specific relative humidity for these salts in combination with the temperature exceed the limit value. In [13], results of metallographic investigations of indoor pool ventilation ducts made of stainless steel type 1.4301 were presented. It was found that the corrosive degradation of this steel occurred as a pitting corrosion in a chloride medium in the form of pinholes and micro-cracking.

Aluminium structures are considered as corrosion resistant material as well as stainless steels [3]. Corrosion resistance is one of the most important features of aluminium [8].

However, aluminium may corrode in some cases. The problem of aluminium corrosion is widely discussed in [9]; the author pointed out that aluminium is resistant to atmospheric corrosion thanks to inert aluminium oxide film being insoluble in water and this blocks further oxidation. Corrosion resistance of aluminium depends on chemical composition, the fabrication process, heat treatment and the stress field. What is important is that usually, corrosion does not reduce the safety of aluminium structures, but only decreases the aesthetics of the structures. Mazzolani in [12] presented the influence of alloy additions to pure aluminium on corrosion resistance and proposed systems which may protect the surface of the metal. He described types of corrosion of aluminium (surface, concentrated, intergranular, lamellar, stress, and corrosion by contact) and he particularly focused on corrosion of aluminium in contact with steel. He also pointed out that the contact aluminium with a humid and corrosive environment should be limited. Aluminium should be separated from concrete, mortar, timber and bricks. A similar suggestion is presented in [11]. He suggested coating aluminium with bitumen to separate it from concrete. In his opinion, the pure aluminium exhibited the highest corrosion resistance. Aluminium is dissolved by fluorine, sodium hydroxide and potassium hydroxide. Hydrochloric acid, copper and bromine are very corrosive for aluminium. Aluminium corrodes in seawater, sea air, industrial air, and when in contact with steel, lead, copper and mercury. Aluminium does not corrode in contact with zinc, cadmium and stainless steel. Furthermore, aluminium does not corrode in aluminium and iron Alfin brake drums thanks to accurate connection of both materials. Mromliński underlined that corrosion intensity decreases rapidly after two years. Jasiczak and Hajkowski suggested using aluminium at a pH of between four and nine [6] and checking the possibility of corrosion using the Pourbaix diagram [17]. Siwowski described an example of corrosion of aluminium in contact with steel in an aluminium bridge deck [19]. The aluminium bridge deck corroded because of contact aluminium with steel rivets.

2. Corrosion of stainless steel

The first part of the paper covers an analysis of the corrosion of stainless steel that was carried out on the example of ventilation ducts installed in the pool hall of The Centre for Tourism and Recreation [18].

2.1. Macroscopic assessment of installed ventilation ducts

The macroscopic assessment of the current state of ventilation ducts allowed determining the nature of reasons for potential damage. It was recognised that several types of damage and corrosion had occurred within the ventilation ducts mounted over the basin of the pool. One of these was pitting corrosion, which occurs when the atmosphere contains chlorides and the passive layer of stainless steel is locally damaged. In the analysed sample, the pitting corrosion occurs in the form of pinholes and micro-cracks (Fig. 1).

The rate of this type of corrosion significantly increases at elevated temperatures. A corrosion cavity develops and can lead to the complete perforation of the metal sheet.

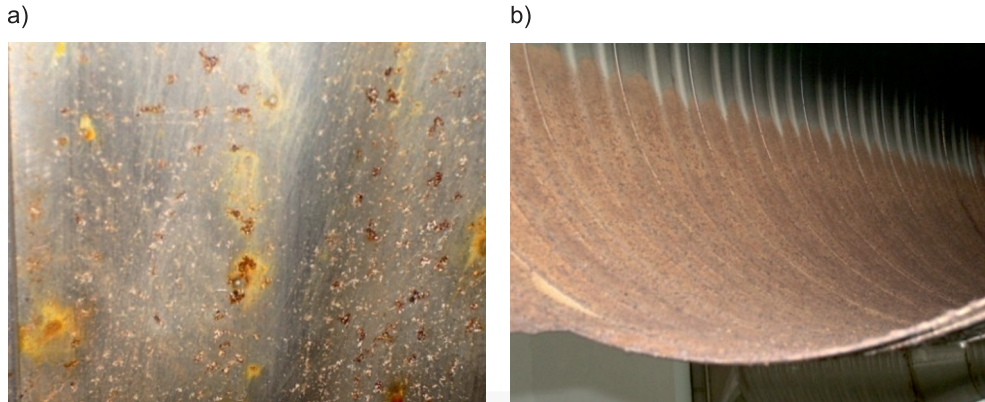

Fig. 1. Pitting corrosion: a) visible micro-cracking and pinholes; b) deposits of corrosion on the surfaces of ventilation ducts [18]

Stress corrosion cracking (SCC) in the form of layers of light and rust deposits on the fold line of the sheet is presented in Fig. 2a. One can observe linearly placed local pitting corrosion as a consequence of tensile stresses due to cold-rolling. Stress corrosion cracking occurred with the equipment exposed to swimming pool atmospheres and arises due to the combination of the mechanical load and the corrosive environment with free chloride ions. It is worth noting that the SCC process is usually difficult to detect before cracking occurs because it develops inside the material among the crystals. Therefore, designers should keep in mind that this corrosion is present in members subjected to tensile stress, as a result of external load action or in the form of residual stresses due to welding, cold rolling or deep forming.

Another type of corrosion detected in the analysed vent ducts was crevice corrosion. This type of corrosion appears when the pH reaches a critical value called the ‘depassivation

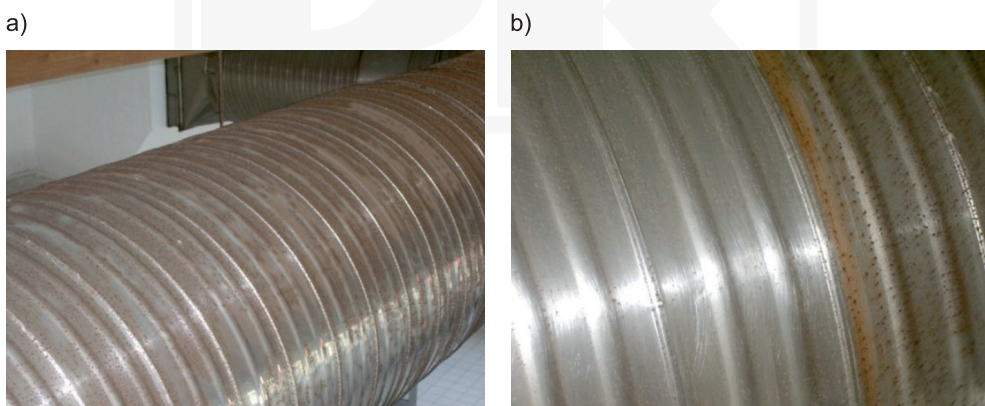

Fig. 2. a) example of stress corrosion cracking due to cold rolling; b) example of crevice corrosion [18]

pH'. It develops at the region within a crevice which promotes the accumulation of chemical deposits. Crevice corrosion associated with the presence of gaps within a connection is presented in Fig. 2b.

2.2. Analysis of the chemical composition

Analysis of chemical composition of material and corrosion products was performed based on results supplied by the contractor. The chemical composition was conducted by the gravimetric method (Table 1).

Table 1

Chemical composition of material [18]

Chemical element	Tested sample (vent duct) [%]	X2CrNiMo17-12-2 (1.4404) (PN EN 10088-1:2007) [%]
C	0.03	0.03
Si	0.028	1.00
Mn	1.90	2.00
P	0.025	0.045
S	0.015	0.15
Cr	16.80	16.5–18.5
Ni	10.00	10.0–13.0
Mo	2.35	2.0–2.5

It was found that the material of vent ducts installed in the swimming pool corresponds to the stainless steel grade X2CrNiMo17-12-2 (1.4404) according to [14]. Based on the analysis of the chemical composition of the steel sample, it can be concluded that the content of the Cr and Ni is placed in the lower limits of the range referred to in [14], while the carbon content reaches an upper limit. As is well known, a low content of Cr and Ni can influence the reduction in corrosion resistance. Furthermore, in environments containing spray steam and free chlorine ions, the risk of corrosion increases significantly. Particular attention should be paid to the very high content of chlorine that was found during the analysis of the chemical composition of corrosion products (Table. 2). The content of Cl reaches approx. 35% in the worst place.

Table 2

Chemical composition of corrosion products [18]

Chemical element [%]	O	Al	Si	Cl	Ca	Cr	Fe	Ni	K	Mn
place 1	18.14	1.23	3.22	24.09	5.26	4.49	29.55	14.04	–	–
place 2	22.07	4.89	12.68	34.65	6.41	1.76	6.62	10.30	0.63	–
place 3	16.25	0.24	0.44	20.25	4.56	9.43	27.92	17.55	–	3.37

3. Corrosion of aluminium in aluminium and concrete composite structures

In the second part of the paper, corrosion of aluminium in contact with steel in aluminium and concrete composite structures is analysed. Electromechanical corrosion occurs when aluminium is in contact with another metal with a liquid between two metals and a voltaic pile is established. This type of corrosion is widely discussed in [9]. The contact voltage of steel with respect to aluminium is 850 mV. Note that aluminium may corrode in contact with steel because aluminium has a lower voltage than steel. For this reason, it is necessary to separate steel from aluminium. Steel and aluminium may be separated using insulating materials like elastomeric tape, rubber or zinc plating. Steel bolts should be galvanised or electroplated. An example of insulating steel from aluminium is presented in Fig. 3. Insulating material should extend beyond the contact area.

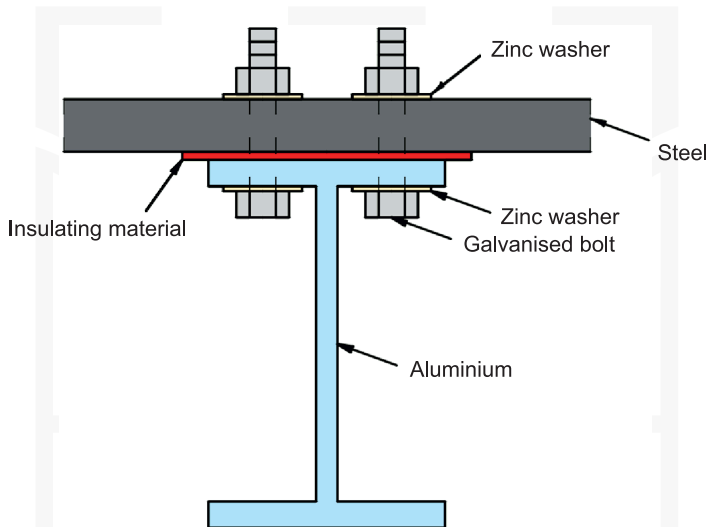

Fig. 3. Insulating steel from aluminium

Aluminium and concrete structures are a type of composite structures which consists of an aluminium beam, a concrete slab, steel sheeting and connectors [16] (Fig. 4).

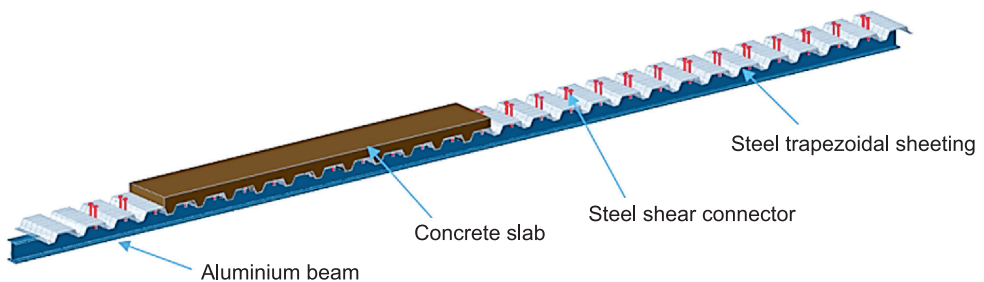

Fig. 4. An aluminium and concrete composite beam

A connection an aluminium beam with a concrete slab using special connectors is a quite new solution. Aluminium and concrete structures may be used in durable constructions. For this reason, they should be corrosion resistant. The aluminium beam is joined with the concrete slab using a steel shear connector [20] which should be galvanised to avoid corrosion of the aluminium (Fig. 5).

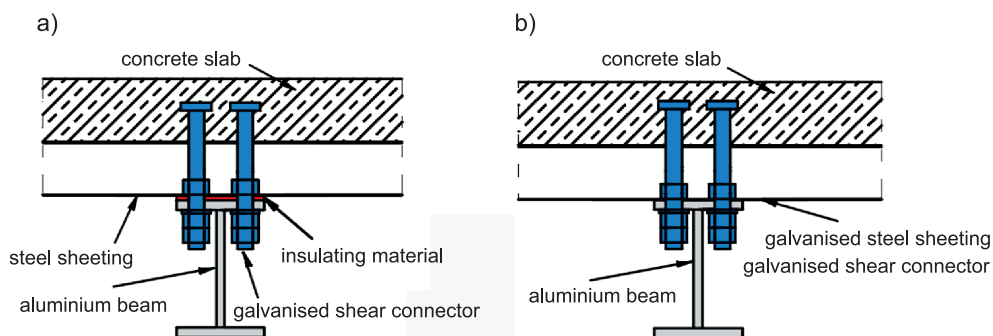

Fig. 5. A corrosion protection of the aluminium beam: a) when steel sheeting is not galvanised; b) when steel sheeting is galvanised

When steel sheeting is not galvanised, an insulating material should be applied between the aluminium flange and the steel sheeting, for example, elastomeric tape. When steel sheeting is galvanised, insulating material is unnecessary. Fresh concrete is separated from aluminium by the galvanised steel sheeting.

4. Conclusions

Based on the presented examples, it can be concluded that stainless steel is susceptible to stress corrosion cracking in aggressive environments as deposits of chloride salts and very specific relative humidity in combination with the temperature. This is particularly dangerous in the case of load bearing members subjected to tension stresses which are not cleaned. The lack of maintenance of ventilation ducts with condensed water and cleaning agents without chlorine, results in local damage to the passive layer of stainless steel and causes pitting corrosion. Another mistake is the use of corrugated metal sheet, because cold-rolling provides relatively high residual stresses. Moreover, the folds disturb easy cleaning to remove the accumulation of aggressive chloride. As a consequence, the rapid develop of stress corrosion cracking is observed. In conclusion, the application of stainless steel grade 1.4404 for vent ducts in the swimming pool was an inappropriate choice. To ensure the proper design of this type of structural member, the designers should follow the recommendation contained in the relevant norms. In the example, according to the PN-EN 1993-1-4 [15] in swimming pool's corrosive chloride environment, ventilation ducts should be designed with the following grades of steel: austenitic steels alloyed, 1.4439/X2CrNiMoN17-13-5 or 1.4539/X1NiCrMoCu25-20-5, 1.4547/X1CrNiMoCuN20-18-7 or 1.4529/X1NiCrMoCuN25-20-7 and ferritic-austenitic (duplex) 1.4462/X2CrNiMoN22-5-3. Designers should also consider the alternative method

which is based on zinc coating technology. This solution is widely used as anti-corrosion protection of steel structures. It is characterised by ease of implementation, its relatively low cost and high efficiency. The zinc layer provides anodic protection which is quite effective in case of negative impact of corrosive environment.

In the case of aluminium, it was proposed that it is one of the best materials used in building construction in terms of corrosion resistance. However, as with stainless steel it may corrode when it is used incorrectly. Corrosion does not usually decrease the safety of aluminium structures, but only damage the aesthetics of the structures. What is more, corrosion intensity may decrease rapidly after two years. Aluminium and concrete structures are a fairly new structural solution. They may be used in durable structures and they should be corrosion resistant. Therefore, designers should keep in mind that aluminium may corrode in contact with steel, because aluminium has a lower voltage than steel. Steel shear connectors in aluminium and concrete composite structures should be galvanised to avoid the corrosion of aluminium in contact with steel. When steel sheeting is not galvanised, an insulating material should be applied i.e. elastomeric tape between the aluminium flange and the steel sheeting.

Financial support from the DS grant 11-405/2015 is kindly acknowledged.

References

- [1] Bitondoa C., Bossioa A., Monettaa T., Curionib M., Belluccia F., *The effect of annealing on the corrosion behaviour of 444 stainless steel for drinking water applications*, Corrosion Science, Vol. 87, 2014, 6-10.
- [2] George G., Shaikh H., *Introduction to Austenitic Stainless Steels*, Corrosion of Austenitic Stainless Steels, Mechanism, Mitigation and Monitoring, [in:] Woodhead Publishing Series in Metals and Surface Engineering, 2002, 1-36.
- [3] Gwóźdz M., *Project problems of contemporary aluminium structures*, Czasopismo Techniczne, 4-A/2007, 281-286 (in Polish).
- [4] Houska C., Fritz J., *Successful Stainless Swimming Pool Design*, British Stainless Steel Association, Construction Specifier Magazine, 2005, 1-9.
- [5] Iversen A., Prosek T., *Atmospheric stress corrosion cracking of stainless steels in swimming pool environments*, Proceedings of European Stainless Steel Conference, 2008, 49-56.
- [6] Jasiczak J., Hajkowski M., *Corrosion susceptible elevations made with aluminium plates working in treatment's plant environment*, Ochrona Przed Korozją, 5s/A, 2008, 79-85 (in Polish).
- [7] Kamachi Mudali U., Pujar M.G., *Pitting Corrosion of Austenitic Stainless Steels and Their Weldments*, Corrosion of Austenitic Stainless Steels, Mechanism, Mitigation and Monitoring, A volume in Woodhead Publishing Series in Metals and Surface Engineering, 2002, 74-105.
- [8] Mazzolani F.M., *Aluminium Alloy Structures*, E & FN SPON, an imprint of Chapman&Hall, London 1995.
- [9] Mazzolani F.M., *Aluminium Structural Design*, Springer-Verlag Wien GmbH, Wien 2003.
- [10] Mietz J., Isecke B., *Stainless steels for applications in civil engineering*, Stainless Steel World Conference, 2001, 334-339.
- [11] Mromliński R., *Aluminium structures*, Arkady, Warszawa 1975 (in Polish).

- [12] Ningshen S., Kamachi Mudali U., *Uniform Corrosion of Austenitic Stainless Steels*, Corrosion of Austenitic Stainless Steels, Mechanism, Mitigation and Monitoring, A volume in Woodhead Publishing Series in Metals and Surface Engineering, 2002, 37-73.
- [13] Ozgowicz W., Kalinowska-Ozgowicz E., Lesz S., *Ventilation ducts of an indoor swimming-pool – materials and technology possibilities*, Rynek Instalacyjny 10, 2013 (in Polish).
- [14] PN EN 10088-1:2007 Stale odporne na korozję, Gatunki stali odpornych na korozję, Polski Komitet Normalizacyjny (in Polish).
- [15] PN-EN 1993-1-4:2007 Projektowanie konstrukcji stalowych, Część 1–4: Reguły ogólne, Reguły uzupełniające dla konstrukcji ze stali nierdzewnych, Polski Komitet Normalizacyjny (in Polish).
- [16] Polus Ł., Szumigała M., *A numerical analysis of the resistance and stiffness of the aluminium and concrete composite beam*, Civil and Environmental engineering reports, CEER 15 (4), 2014, 99-112.
- [17] Pourbaix M., *Wykłady z korozji elektrochemicznej*, Polish Scientific Publishers, Warszawa 1978. (in Polish)
- [18] Rzeszut K., *Expert report on the causes of ventilation ducts corrosion in indoor swimming pool environments*, Poznan University of Technology, Poznań 2011 (in Polish).
- [19] Siwowski T., *Aluminium bridge decks*, Technical University of Rzeszów Publisher, Rzeszów 2008 (in Polish).
- [20] Szumigała M., Polus Ł., *A numerical modelling of the load capacity of the shear connector to aluminium and concrete structures*, II International Polish-Ukrainian Scientific-Technical Conference Current Problems of Metal Structures, Gdańsk, 27–28 November 2014, 221-224.

