

PAVOL ĎURICA*, MARIANNA ŠUŠTIAKOVÁ*, RADOSLAV PONECHAL*,
JÁN RYBÁRIK*

MEASURED AND SIMULATED PARAMETERS OF WOODEN LIGHTWEIGHT EXTERNAL WALLS

POMIAROWE ORAZ SYMULACYJNE PARAMETRY LEKKICH DREWNIANYCH ŚCIAN ZEWNĘTRZNYCH

Abstract

The partial knowledge of the area of thermo-technical properties of wooden lightweight external walls is presented in this article. The distribution of temperatures inside the structure during a typical winter week is described as observed on samples of walls built in a chamber pavilion type. What is compared is the thermal performance variant of sandwich construction walls obtained on the basis of calculations, measurements and simulations.

Keywords: long time testing measurements, wooden lightweight external walls, temperatures, simulations

Streszczenie

W artykule przedstawiono częściowy zakres wiedzy na temat właściwości cieplno-technicznych drewnianych lekkich ścian zewnętrznych. Rozkład temperatury wewnątrz struktury podczas typowego zimowego tygodnia został opisany i obserwowany dla próbek ścian w komorze typu pawilon. Na podstawie obliczeń, pomiarów oraz symulacji dokonano porównania właściwości termicznych ściany warstwowej.

Słowa kluczowe: badania długotrwałe, drewniane lekkie ściany zewnętrzne, temperatura, symulacje

* Doc. Eng. Pavol Ďurica, C.Sc. Eng. Marianna Šuštiaková, Eng. Radoslav Ponechal, Doc. Ph.D. Eng. Ján Rybárik, Department of Building Engineering and Urban Planning, Faculty of Civil Engineering, University of Žilina.

1. Introduction

Temperature measurements were taken of the lightweight-construction of the external wall, which was made of three different material solutions and three different colored exterior side surfaces. Temperatures flow patterns were developed on the basis of temperature measurements taken of a sample of the wall built in a climate chamber in the laboratory pavilion type centre KPSU FCE ŽUŽ (KPSU – Department of Building Constructions and Urban Planning, FCE – Faculty of Civil Engineering, ŽUŽ – University of Žilina). Its facade was oriented to the south with a rotation of 17° to the west. The dimensions of the monitored experimental walls were 3670×2670 mm and they comprised five fields (Fig. 1). The walls differ in material composition and surface color. The first, second, fourth and fifth fields constituted diffusion sealed constructions while the third field represented a diffusion open construction. The composition of the wall from the interior toward the exterior was as follows: OSB, PE film (except for the third field), infill insulation, exterior Hofatex insulation, and a thin coating plaster. Temperatures were recorded at 30 minute intervals in areas: in a fragment of the external wall on the outer surface of the structure, under the plaster, under an additional thermal insulation, and under the infill thermal insulation (Fig. 2). Indoor air temperature was kept 20°C and the chamber's relative humidity was kept at 50%. The sample was being exposed to actual external climate conditions from the outside. Indoor climate parameters, relative humidity and indoor air temperature were maintained by an air handling unit.

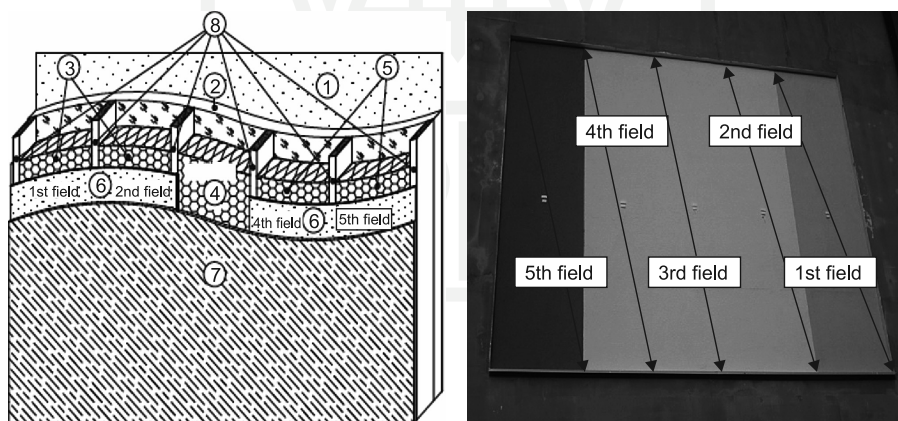

Fig. 1. Left: external plaster/4 mm; 2– woodfiber board/100 mm; 3 – Stone wool insulation/220 mm; 4 – Hemp insulation/220 mm; 5 – Mineral wool insulation/220 mm; 6 – vapor layer/0,2 mm; 7 – OSB/12mm; 8 – wood column/60×220 mm, from left to right 1st, 2nd, 3rd, 4th, 5th field, right external view of climate chamber in the laboratory center pavilion type

The sensors were placed in the middle of the field. The temperature flow pattern in the lightweight-construction of the external wall were observed for one week of the cold period between January 27th and February 2nd 2012 ($\theta_{ae, \min} = -18.9^\circ\text{C}$, $\theta_{ae, \max} = 4.6^\circ\text{C}$).

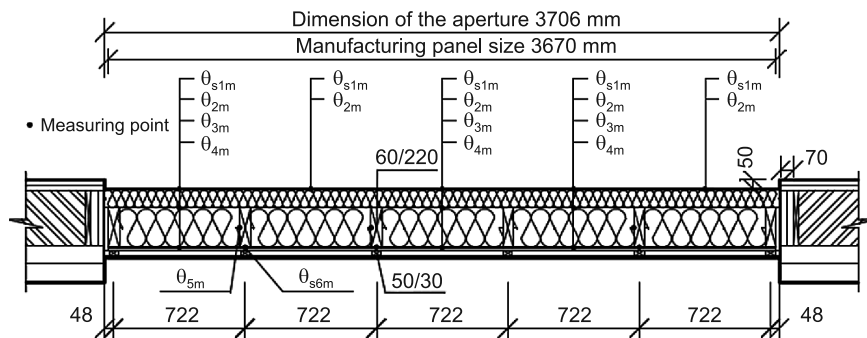

Fig. 2. Diagram of the observed temperatures: θ – temperature ($^{\circ}\text{C}$), s – surface, m – measured temperature, 1 – external plaster, 2 – lower plaster, 3 – lower thermal insulation, 4 – lower infill thermal insulation, 5 – middle of column, 6 – inner surface column 2

Different temperature patterns in the construction (Figs. 4–6) were not only influenced by its different material compositions, but also by the natural effects of its environment and the different light absorption and reflectance attributable to surface treatment. The highest temperatures were measured, as expected, on the grey-colored surface finish exhibiting the lowest (34%) reflectance of solar radiation that absorbs most light radiation, while examining the temperature on the surface of the structure. The third field with a diffusion open structure has the lowest surface temperature at the time of exposure to the sun when compared to the white-finish fields. This had been caused by the diffusion flux of water vapor, which increases the specific heat of layers and, therefore, necessitated the addition of more heat to raise the temperature of the material. The surface temperature of the wall dropped below the ambient temperature in all the fields at night during the period. At that time, minimum temperatures were recorded mostly in the fourth white-finish field (which had the reflectance of solar radiation of almost 100%), and the first yellow-finish field (at 61% reflectance of solar radiation).

2. Thermal simulations

ESP-R software was used for thermal simulation. The simulated model reproduces reality in a research lab. Its facade is oriented to the south with a rotation of 17° to the west. The internal temperature was set according to the measured temperature values of the interior. A test reference year from the IWEC (International Weather for Energy Calculations) Ostrava database was used to simulate the thermo physical processes present in construction. A day with nearly the same conditions as those measured had been chosen from the IWEC database because of the possibility for comparing the simulated temperature patterns in the winter with the experimental measurements. Measured outside air temperatures were used in the simulations instead of those from the database.

The temperatures inside the layers of each field have been documented as the results. On the basis of the simulation results of the heat flux, the heat flow path coefficients

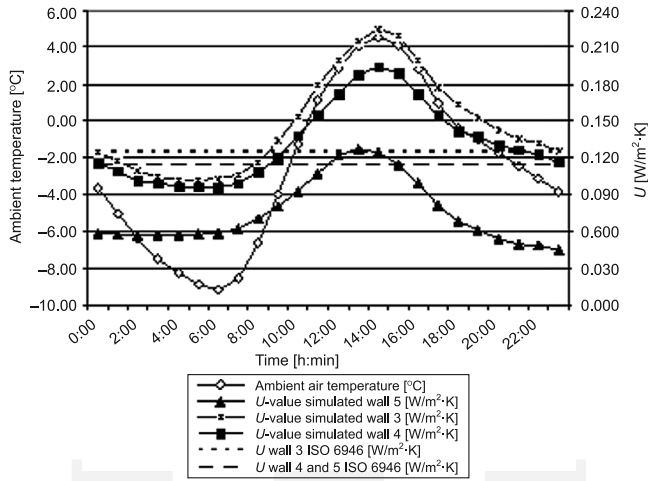

Fig. 3. Ambient temperature and U -value patterns obtained from simulation

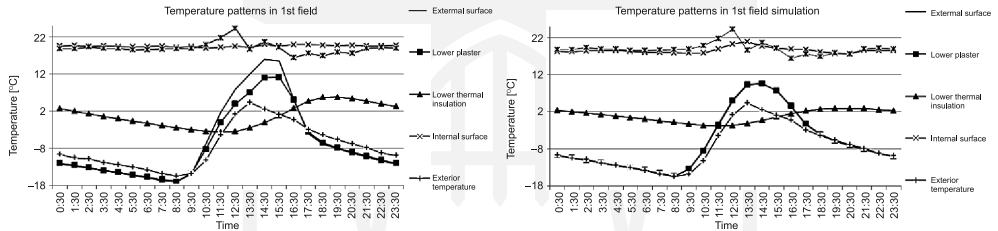

Fig. 4. Temperatures of the construction measured (on the left) and simulated (on the right) on 30th January, 2012

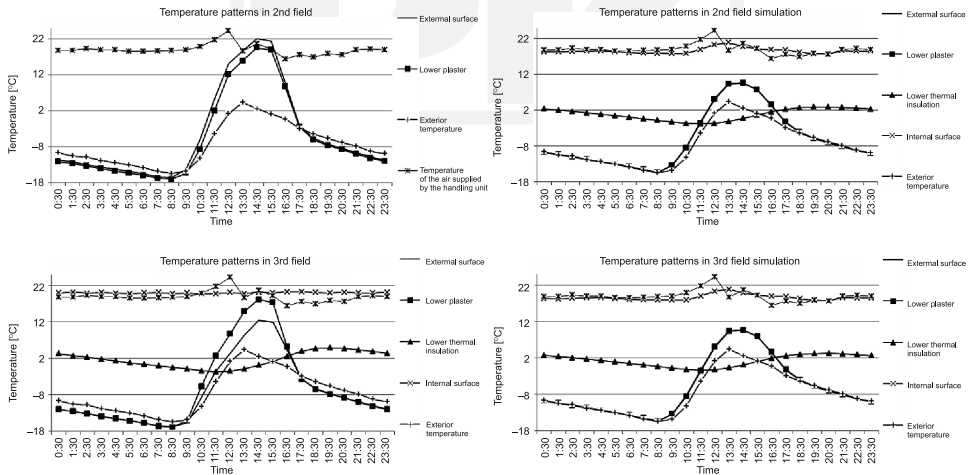

Fig. 5. Temperatures of the construction measured (on the left) and simulated (on the right) on 30th January, 2012

were determined for the different fields of the outer wall (Fig. 3). U -value patterns of the temperature cross-sectional structures (Fig. 4–6) display a significant effect of solar radiation absorption relative to heat flow and temperature in the reported structure.

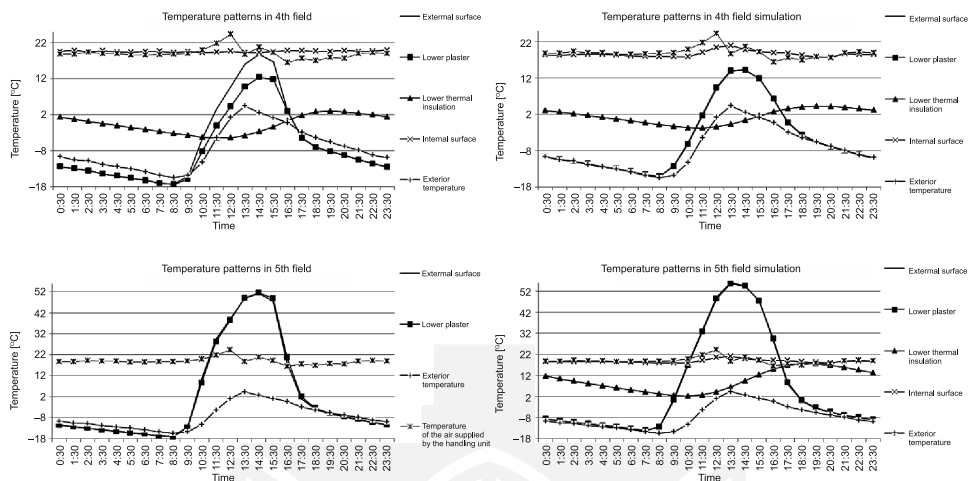

Fig. 6. Temperatures of the construction measured (on the left) and simulated (on the right) on 30th January, 2012

3. Conclusions

The difference between outside temperature and that under the plaster was higher in reality than in the simulation. Surface temperatures were, with the exception of the third field, higher than outside temperatures. The path of temperatures in the layers of the third field is affected by the diffusion of water vapor, which increases the thermal conductivity of the material. The energy of sunlight is, therefore, passed on to the construction faster. The measured temperature of external surfaces fell below the outside air temperature at night, unlike in the simulation, which had not taken into account the impact of negative radiation of the night sky. Temperatures of the inner surface of the structure per measurements were more stable as shown by the calculations in the simulation. The calculation of heat transfer coefficients showed highly variable non-stationary progressions, which were significantly different from the stationary standard values (Fig. 3, Table 1). Surprisingly, apparent opposite progressions of U -values are recorded at midday which confirms the findings in [4], and [5] as listed in the reference section of this paper.

Table 1

The material characteristic and U-values of each field in stationary conditions

Material (1st and 2nd fields)	Description	d	λ	ρ	c	μ	R	
		[m]	[W/ (m×K)]	[kg/m ³]	[J/(kg×K)]	[-]	[m ² ×K/W]	
External plaster	StoSilco	0.004	0.7	1900	720	40	0.01	
Woodfiber board	HofaTexSysThem	0.1	0.045	210	2100	5	2.22	
Stone wool insulation	Rockwool MWW	0.22	0.037	40	840	1	5.95	
Vapor layer	Isover Vario KM Duplex	4.00E-05	1	2000	–	90000	0.00	
							$U = 0.120$ [W/(m ² ×K)]	
Material (3rd field)	Description	d	λ	ρ	c	μ	R	
		[m]	[W/ (m×K)]	[kg/m ³]	[J/(kg×K)]	[-]	[m ² ×K/W]	
External plaster	StoSilco	0.004	0.7	1900	720	40	0.01	
Woodfiber board	HofaTexSysThem	0.1	0.045	210	2100	5	2.22	
Hemp insulation	Cannabest Plus	0.22	0.04	36	1200	1.9	5.50	
							$U = 0.127$ [W/(m ² ×K)]	
Material (4th and 5th fields)	Description	d	λ	ρ	c	μ	R	
		[m]	[W/ (m×K)]	[kg/m ³]	[J/(kg×K)]	[-]	[m ² ×K/W]	
External plaster	StoSilco	0.004	0.7	1900	720	40	0.01	
Woodfiber board	HofaTexSysThem	0.1	0.045	210	2100	5	2.22	
Mineral wool insulation	Isover ENV	0.22	0.035	24	840	1	6.29	
Vapor layer	Isover Vario KM Duplex	4.00E-05	1	2000	–	90000	0.00	
							$U = 0.115$ [W/(m ² ×K)]	

The presented results were obtained with the support of European Regional Development Fund grant projects and the “Research Centre of the University of Žilina” Slovak state budget projects, ITMS 26220220183 and VEGA no. 1/0729/13.

References

- [1] Chmúrny I., *Tepelná ochrana budov*, Jaga Group, Bratislava 2003.
- [2] Amandine Piot and col., *Experimental wooden frame house for the validation of whole building heat and moisture transfer numerical models*, Energy and Buildings, Vol. 43(6), 2011, 1322-1328, <http://www.sciencedirect.com/science/article/pii/S037877881100017X> – 3.02.2014.
- [3] Asan H., *Numerical computation of time lags and decrement factor for different building materials*, <http://amet-me.mnsu.edu/userfileshared/solarwall/Solar%20Passive%20%28Trombe%29%20Wall%20Documents/Technical%20Publications/Numerical%20computation%20of%20time%20lags%20and%20decrement%20factors%20for%20different%20building%20materials.pdf> – 4.11.2013.
- [4] Anderson B.R., *Conventions for U-Value Calculations*, IHS – BRE Press, 2006, 2 edition.
- [5] Anderson B.R., *The measurement of U-values on site*, <http://web.ornl.gov/sci/buildings/2012/1985%20B3%20papers/001.pdf> – 4.11.2013.
- [6] Štúňová M., Ďurica P., *The course of temperatures in construction of lightweight external wall in stationary conditions of the internal environment and the actual conditions of outdoor climate*, Conference TRANSCOM Žilina, Slovak Republic, 2013.
- [7] STN 730540:2012 Thermal properties of building structures and buildings, Thermal protection of buildings, Parts 1, 2, 3, Slovak Standards Institute, Bratislava 2012.



