

MAŁGORZATA JANUS-MICHALSKA\*, RAFAŁ ZAWIŁA\*\*

## COMPARATIVE STUDY OF THE LOAD-BEARING CAPACITY OF COMPOSITE LAMINATED CYLINDRICAL SHELLS

### STUDIUM PORÓWNAWCZE NOŚNOŚCI WIELOWARSTWOWYCH CYLINDRYCZNYCH POWŁOK KOMPOZYTOWYCH

#### Abstract

This paper presents a comparison of pressure for composite laminated cylinders leading to progressive damage of subsequent plies. Laminates made of epoxy resin with glass fibre used in various ply stacking sequences are considered. Numerical calculations based on Mathcad author's code are performed. Results utilising last ply failure criterion are specified. The effects of subsequent ply angles on load capacity is investigated.

*Keywords: composite laminate, progressive damage, load-bearing capacity*

#### Streszczenie

Artykuł przedstawia porównanie wartości ciśnienia wewnętrznego dla kompozytowych zbiorników cylindrycznych prowadzącego do zniszczenia kolejnych warstw. Rozważono laminaty z żywic epoksydowych zbrojonych włóknami szklanymi o różnorodnym ułożeniu warstw. Obliczenia numeryczne przeprowadzono w oparciu o autorskie procedury napisane w programie Mathcad. Wyznaczanie nośności opiera się na kryterium zniszczenia ostatniej warstwy. Na podstawie otrzymanych wyników zbadano wpływ kąta ułożenia kolejnych warstw na nośność.

*Słowa kluczowe: kompozyty wielowarstwowe, nośność, progresywne niszczenie warstw*

**DOI: 10.4467/2353737XCT.15.165.4340**

\* Ph.D. Eng. Małgorzata Janus-Michalska, Institute of Structural Mechanics, Faculty of Civil Engineering, Cracow University of Technology.

\*\* M.Sc. Eng. Rafał Zawila, Graduate of Faculty of Civil Engineering, Cracow University of Technology.

## 1. Introduction

Composites are increasingly used in engineering structures due to their high strength and stiffness. To achieve improved strength and stiffness, composites are made of layers with unidirectional continuous fibers in the form of a laminate. The mechanics of laminates treated as special structures is formulated in a special convention and given in many books and manuals, for example by Milton [11], Laszlo & Kollar [9], Jones [8], German [5], Muc [12].

Composite laminates not only offer high levels of strength, but also maintain load-bearing capacity even in the presence of damage to individual plies. This property has been analysed by Craddock [2], Chang [3], German [6].

The wide use of laminates in a variety of engineering fields involves the use of special design rules. Some aspects of designing conditions can be developed and added to design procedures.

Laminates are a family of materials for which mechanical properties can be tailored. The matrix, the reinforcement material and the volume of reinforcement can be varied to achieve the required properties. The effect of the stacking layer sequence on damage tolerance was studied by Bezazi [1], Park et al. [14] and Tsau & Liu [16]. The influence of the stacking sequence on the stress distribution of laminates was described by Tsau & Liu [16]. Park [15] made an attempt to find the optimal stacking for various loads.

The present work is focused on tailoring the laminate structure by adjusting the angle of laminate plies for achieving the maximal load bearing capacity. Laminates made of epoxy resin with glass fibre are chosen as a material used for the cylinder structure of pressure tanks.

## 2. Classical theory of laminates

The elastic behaviour of laminates is described by the generalised Hooke's law [8, 9], which linearly relates the generalised forces to the generalised strains as written below:

$$\begin{pmatrix} \mathbf{N} \\ \mathbf{M} \end{pmatrix} = \begin{bmatrix} \mathbf{A} & \mathbf{B} \\ \mathbf{B} & \mathbf{D} \end{bmatrix} \begin{pmatrix} \boldsymbol{\mu}^0 \\ \boldsymbol{\kappa}^0 \end{pmatrix} \quad (1a)$$

where:

- $\mathbf{N}$  – in-plane forces,
- $\mathbf{M}$  – bending moments,
- $\boldsymbol{\varepsilon}^0$  – midplane strains,
- $\boldsymbol{\kappa}^0$  – midplane curvatures,
- $\mathbf{A}$  – membrane stiffnesses,
- $\mathbf{D}$  – bending stiffnesses,
- $\mathbf{B}$  – membrane-bending coupling stiffness,
- $\mathbf{A}, \mathbf{B}, \mathbf{D}$  – fourth order tensors.

Stiffness tensors are defined as weighted integrals of ply stiffnesses  $\bar{\mathbf{Q}}$  over the plate thickness  $t$  and can be written as follows:

$$\mathbf{A} = \sum_{k=1}^N (\bar{\mathbf{Q}})_k (z_k - z_{k-1}), \quad \mathbf{B} = \frac{1}{2} \sum_{k=1}^N (\bar{\mathbf{Q}})_k (z_k^2 - z_{k-1}^2), \quad \mathbf{D} = \frac{1}{3} \sum_{k=1}^N (\bar{\mathbf{Q}})_k (z_k^3 - z_{k-1}^3) \quad (1b)$$

where:

$N$  – number of layers,

$z_k$  – distances of layer from reference plane, as shown in Fig. 1.

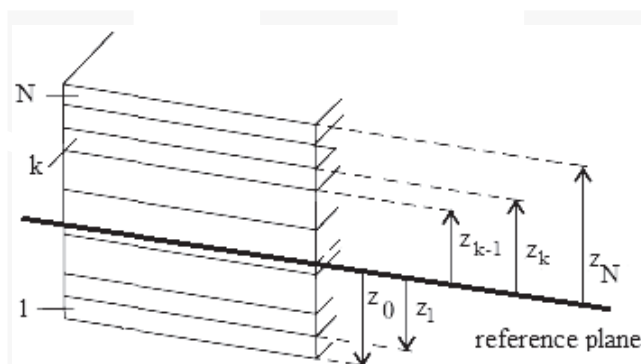

Fig. 1. Distances of layers from reference plane

Ply stiffnesses  $\bar{\mathbf{Q}}$  in global system of coordinate can be obtained by transformation of stiffness tensor  $\mathbf{Q}$  from local ply coordinate system associated with fiber direction, as can be seen in Fig. 2.

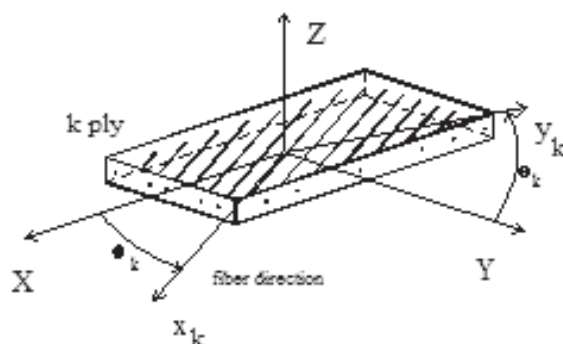

Fig. 2. Global  $(XYZ)$  and local  $(x_k, y_k, z_k)$  coordinate system

Constitutive equations given by the relationship  $\boldsymbol{\sigma} = \mathbf{Q}\boldsymbol{\varepsilon}$  are set in the ply local system of coordinates.

For unidirectional ply, fibre reinforcement non-zero stiffness components are expressed by ply material constants as follows:

$$Q_{1111} = \frac{E_1}{1 - \nu_{12}\nu_{21}}, \quad Q_{1122} = \frac{\nu_{12}E_2}{1 - \nu_{12}\nu_{21}}, \quad Q_{2222} = \frac{E_2}{1 - \nu_{12}\nu_{21}}, \quad Q_{1212} = G_{12} \quad (2)$$

### 3. Failure criteria

The engineering formula for practical design indicates the load at which laminate failure occurs. Many theories are proposed but none of them are sufficient for the description of the failure of the whole laminate. Failure criteria are formulated only for separate ply in the general form:

$$f(\boldsymbol{\sigma}, X_1, \dots, X_N) = 1 \quad (3)$$

where:

- $\boldsymbol{\sigma}$  – state of stress,
- $X_1, \dots, X_N$  – set of strength parameters.

Three criteria are proposed:  
maximum stress criterion

$$X_C < \sigma_1 < X_T, \quad Y_C < \sigma_2 < Y_T, \quad -S < \sigma_6 < S \quad (4a)$$

quadratic criteria, Tsai-Wu

$$\begin{aligned} & \left( \frac{1}{X_T} - \frac{1}{X_C} \right) \sigma_1 + \left( \frac{1}{Y_T} - \frac{1}{Y_C} \right) \sigma_2 + \frac{1}{X_T} \frac{1}{X_C} \sigma_1^2 + \frac{1}{Y_T} \frac{1}{Y_C} \sigma_2^2 + \\ & + \frac{1}{S^2} \sigma_6^2 - \sqrt{\left( \frac{1}{X_T} - \frac{1}{X_C} \right) \left( \frac{1}{Y_T} - \frac{1}{Y_C} \right)} \sigma_1 \sigma_2 \leq 1 \end{aligned} \quad (4b)$$

and Azzi-Tsai-Hill

$$\frac{\sigma_1^2}{X^2} + \frac{\sigma_2^2}{Y^2} - \frac{\sigma_1 \sigma_2}{XY} + \frac{\sigma_6^2}{S^2} \leq 1 \quad (4c)$$

where:

$$X = \begin{cases} X_T - \text{tensile strength for } \sigma_1 > 0 \\ X_C - \text{compressive strength for } \sigma_1 < 0 \end{cases}$$

$$Y = \begin{cases} Y_T - \text{transverse tensile strength for } \sigma_2 > 0 \\ Y_C - \text{transverse compressive strength for } \sigma_2 < 0 \end{cases}$$

$$S \quad - \quad \text{transverse shear strength,}$$

$$\sigma_1, \sigma_2, \sigma_6 \quad - \quad \text{plane stress tensor components in Voigt notation.}$$

The Azzi-Tsai-Hill criterion is a generalisation of the Huber-Mises-Hencky yield condition for orthotropy and is the most frequently used in with regard to engineering usage of laminates.

For quadratic criteria, it is useful to introduce material effort coefficient  $\varphi = \varphi(\sigma, X_1, \dots, X_N)$  defined in such a way that the criterion is written as follows:  $\varphi \leq 1$ .

The given criteria specify the load for which the first ply failure occurs. When this condition is adopted as a failure of the whole laminate, we obtain the first ply failure criterion (FPF criterion). When we follow load changes until the last ply fails, the last ply failure criterion (LPF criterion) is obtained.

#### 4. Last ply failure method and algorithm of strength analysis

With regard to the first ply failure, the whole laminate does not completely fail because unfailed plies carry load. If the applied load is increased, a series of ply failures occur which leads to total failure. For the last ply failure, the final load may be much higher than for the first ply failure. The conclusion is that the LPF method is less conservative than FPF (first ply failure). For our analysis, we use the LPF method with the algorithm of laminate stress analysis proposed by German & Mikulski [6] as shown in Fig. 3.

#### 5. Cylindrical shell

The thin-walled circular cylinder made of 16 plies creating the symmetrical laminate shown in Fig. 4 is considered. Each ply has a thickness of 0.508 mm. Dimensions of the tank are as shown in Fig. 4. The laminate is made of epoxy resin and glass fibre with various ply stacking sequences. The tank is subjected to internal pressure.

The load-bearing capacity is defined as the maximal pressure that can be applied to the tank structure until subsequent ply failure occurs.

The elastic constants and the strength parameters for the individual plies are as follows:

$$E_1 = 137 \text{ GPa} \quad E_2 = 10,40 \text{ GPa} \quad \nu_{12} = 0.3$$

$$X_T = 1500 \text{ MPa} \quad X_C = 1500 \text{ MPa} \quad Y_T = 40 \text{ MPa} \quad S = 68 \text{ MPa}$$

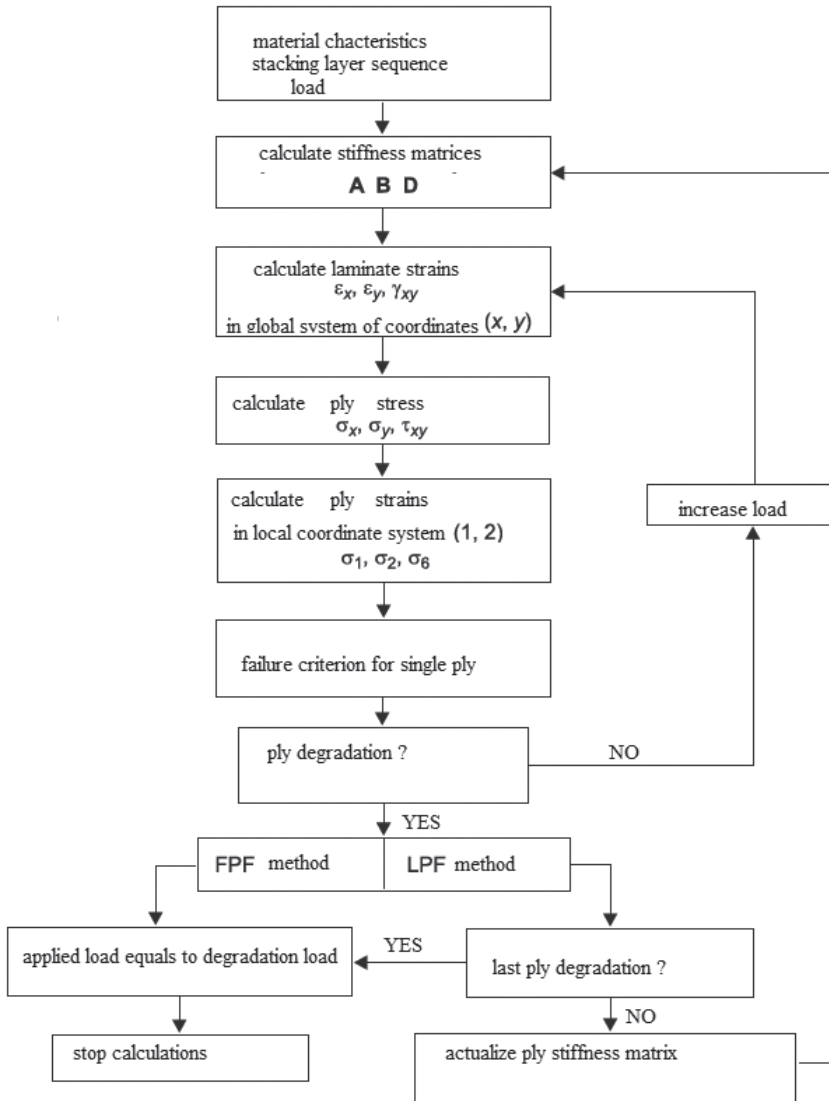

Fig. 3. Algorithm of strength analysis of composite laminate

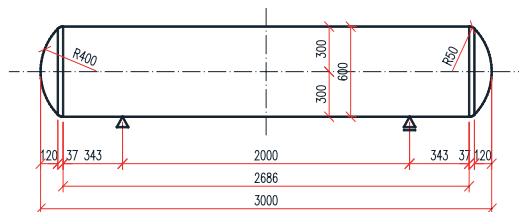

Fig. 4. Composite laminated cylindrical tank dimensions [mm]

## 6. Numerical analysis and results

Simulations were performed using the author's code written in Mathcad. The important new aspect of the work is the implementation of the algorithm presented in Fig. 3. The code is based on the analytical formulation of the problem. Numerical results are compatible with those obtained by the finite element method using ABAQUS code as presented in detail in the work by Zawila [18].

It is worth emphasising that the load bearing capacity and its increase by the use of the last ply failure criterion compared with the use of the first ply criterion is difficult to predict by engineering intuition.

The most interesting results are presented below and collated in Table 1. The first step is defined for FPF. Subsequent steps are defined for the failure of the next plies until the last ply fails (LPF). For calculating the material effort for each individual ply, the Azzi-Tsai-Hill criterion is applied.

For each example, the laminate code, the load-bearing capacity in subsequent steps and the distribution of material effort coefficient over the laminate thickness is given.

Laminate code  $[0, 0, 15, 15, 30, 30, 30, 30]_s$

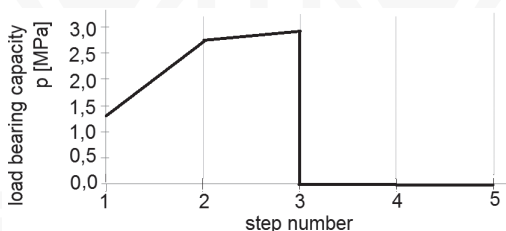

Fig. 5a. Load-bearing capacity in subsequent steps

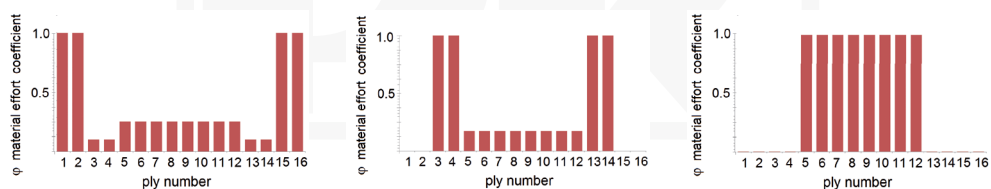

Fig. 5b. Stress distribution

Laminate code  $[90, 90, 75, 75, 75, 60, 60, 60]_s$

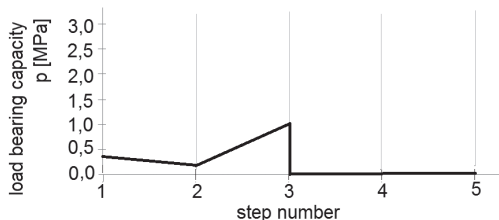

Fig. 6a. Load-bearing capacity in subsequent steps

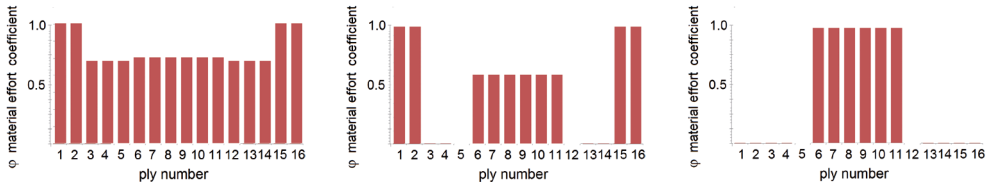

Fig. 6b. Stress distribution

Laminate code  $[0, 0, 15, 15, 15, 30, 30, 30]_s$

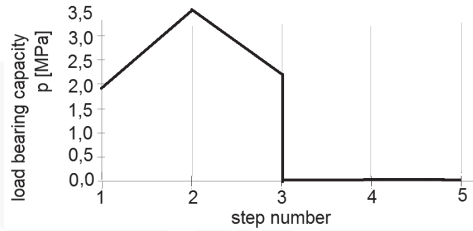

Fig. 7a. Load-bearing capacity in subsequent steps

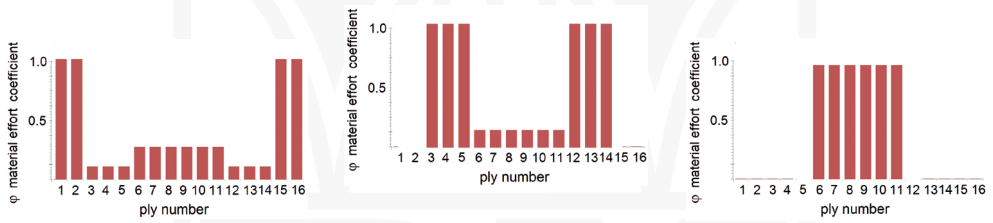

Fig. 7b. Stress distribution

Laminate code  $[90, 90, 45, 45, 45, 45, 0, 0]_s$



Fig. 8a. Load-bearing capacity in subsequent steps

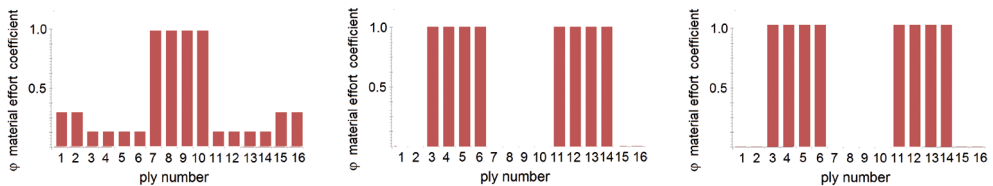

Fig. 8b. Stress distribution



Laminate code  $[75, 75, 60, 60, 45, 45, 90, 90]_s$

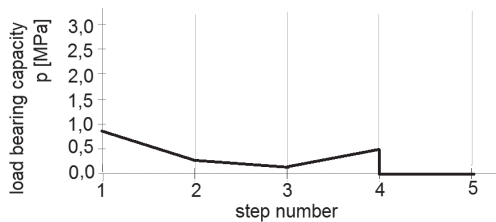

Fig. 9a. Load-bearing capacity in subsequent steps

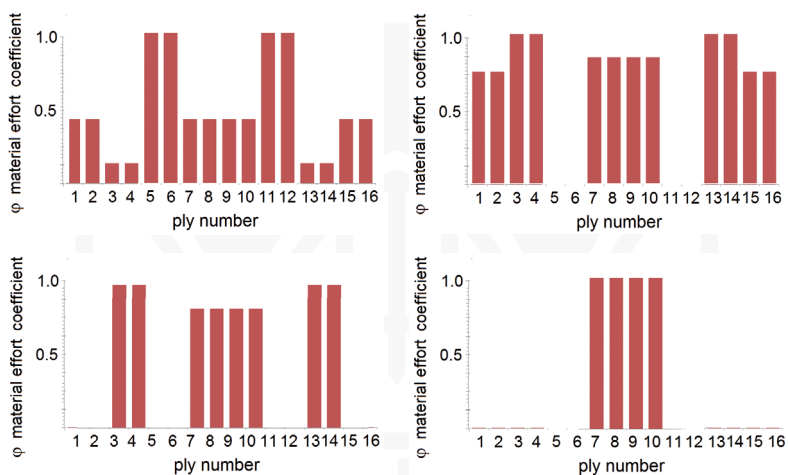

Fig. 9b. Stress distribution

Table 1

Load-bearing capacity p [MPa] for different ply stacking sequences

Laminate code	Step 1	Step 2	Step 3	Step 4	Step 5
$[0, 0, 15, 15, 30, 30, 30, 30]_s$	1.353	2.671	2.776	–	–
$[90, 90, 75, 75, 75, 60, 60, 60]_s$	0.443	0.173	1.000	–	–
$[0, 0, 15, 15, 15, 30, 30, 30]_s$	1.946	3.520	2.083	–	–
$[90, 90, 45, 45, 45, 45, 0, 0]_s$	1.906	2.500	1.776	–	–
$[75, 75, 60, 60, 45, 45, 90, 90]_s$	0.836	0.240	0.181	0.543	–
$[75, 75, 60, 60, 30, 30, 0, 0]_s$	2.136	1.093	0.786	0.571	–
$[75, 75, 15, 15, 45, 45, 90, 0]_s$	2.456	1.903	1.086	0.110	0.087
$[75, 75, 60, 60, 30, 30, 0, 0]_s$	2.136	1.903	0.786	0.507	–
$[75, 75, 60, 60, 30, 30, 15, 15]_s$	2.033	1.903	0.786	0.507	–
$[90, 90, 45, 45, 45, 0, 0, 0]_s$	2.616	2.060	0.543	–	–
$[90, 90, 75, 75, 15, 15, 0, 0]_s$	2.693	1.463	0.726	0.543	–

## 7. Conclusions

The study presented in this paper is focused upon the linear static behaviour and uses the author's Mathcad code based on classical theory of laminates. The effect of the ply angle on the load-bearing capacity of the laminate subjected to membrane forces is described. The presented results show that the last ply failure criterion allows to exploit material better than first ply criterion.

In some cases, the ply angle adjustment gives the significant possibility of raising the load-bearing capacity. It gives reserve of load from first failure to complete damage of composite. These examples as the most interesting are presented in details in Figures 5–9. Figures with index 'a' present the rise of load bearing capacity, figures with index 'b' present which ply fails in subsequent steps. In some cases, the ply angle arrangement does not give the possibility to raise the load-bearing capacity - this means that the maximal load for FPF is greater than the load for LPF – such examples are presented in Table 1.

In future work, we plan to include the design of the structure for the interaction of moments and membrane forces. Additionally, the extension of the method to complex loads will be considered.

## References

- [1] Bezazi A., El Mahi A., Berthelot J., Bezzazi B., *Analyse de l'endommagement des stratifiés en flexion 3-points. Influence de la séquence d'empilement*, XVème Congrès Français de Mécanique, Nancy, 3–7 Septembre, 2001.
- [2] Craddock J.N., *Behaviour of composite laminates after first-ply failure*, Composite Structures, Vol. 3, 1985, 187–200.
- [3] Chang R.R., *Experimental and theoretical analyses of first-ply failure of laminated composite pressure vessels*, Composite Structures, Vol. 49, 2000, 237–243.
- [4] Decolon Ch., *Analysis of Composite Structures*, Hermes Penton Ltd., 2002.
- [5] German J., *Podstawy mechaniki kompozytów włóknistych*, Wydawnictwo Politechniki Krakowskiej, Kraków 1996.
- [6] German J., Mikulski Z., *Numeryczna symulacja stopniowego uszkodzenia się laminatów kompozytowych*, Czasopismo Techniczne, 3-M/2010.
- [7] Hebda M., *Zastosowanie energetycznego kryterium wyłączeniowego do analizy wytrzymałościowej*, praca doktorska, Politechnika Krakowska, Kraków 2006.
- [8] Jones R.M., *Mechanics of Composite Materials*, Taylor & Francis Inc., Philadelphia 1999.
- [9] Laszlo P., Kollar G.S., *Mechanics of Composite Structures*, Springer, Cambridge University Press, Cambridge 2003.
- [10] Lukkassen D., Meidell A., *Advanced Materials and Structures and their Fabrication Processes*, Book manuscript, Narvik University College, HiN, August 31, 2008.
- [11] Milton G.W., *Theory of Composites*, Cambridge University Press, Cambridge 2004.
- [12] Muc A., *Konstrukcje i materiały kompozytowe, problemy i zadania*, Politechnika Krakowska, Kraków 2011.

- [13] Muc A., *Projektowanie kompozytowych zbiorników ciśnieniowych*, Politechnika Krakowska, Kraków 1999.
- [14] Park J.H., Hwang J., Lee C., Hwang W., *Stacking sequence of composite laminates for maximum strength using genetic algorithms*, *Composite Structures.*, **52**, Issue 2, 2001, 217–231.
- [15] Shi C., Mo Y.L., *High-Performance Construction Materials*, World Scientific Publishing Co., Singapore 2008.
- [16] Tsau L.R., Liu C.H., *A comparison between two optimisation methods on the stacking sequence of fibres-reinforced composite laminate*, *Composite Structures*, Vol. 55, Issue 3, 1995, 515–525.
- [17] Verchery G., *Design rules for the laminate stiffness*, *Mechanics of Composite Materials*, Vol. 47, No. 1, March, 2011.
- [18] Zawila R., *Analiza zniszczenia ścianki zbiornika kompozytowego przy niszczeniu kolejnych jej warstw*, praca magisterska, Instytut Mechaniki Budowli, Wydział Inżynierii Łądowej, Politechnika Krakowska, Kraków 2014.

