

RYSZARD WÓJTOWICZ*, PAWEŁ WOLAK**

PERFORMANCE OF A CYCLONE WITH AN ASLANT SHAPED INLET

ANALIZA PRACY ODPYLACZA CYKLONOWEGO Z UKOŚNIE UKSZTAŁTOWANYM KANAŁEM WLOTOWYM

Abstract

This paper presents an analysis of selected operating parameters of a cyclone with a modified inlet. The modification consisted in an angular arrangement of an inlet channel wall. This can result – in view of previously conducted experiments – in a faster insertion of a dusty gas into a swirl motion, an improvement of particles separation process. The analysis was carried out using numeric CFD simulations. The results were compared to those obtained from simulations and lab-measurements for a cyclone with standard inlet.

Keywords: dedusting, cyclone, pressure drop, dedusting efficiency, CFD simulations

Streszczenie

W pracy przedstawiono analizę wybranych parametrów pracy odpylacza cyklonowego ze zmodyfikowanym wlotem. Modyfikacja polegała na kątowym usytuowaniu ścianki kanału wlotowego, co – w świetle prowadzonych wcześniej badań własnych – może skutkować szybszym wprowadzeniem strumienia zapyłonego gazu w ruch wirowy i w jego efekcie poprawą efektywności procesu separacji cząstek. Analizę przeprowadzono wykonując symulacje numeryczne CFD. Uzyskane wyniki porównano z wynikami symulacji i pomiarów laboratoryjnych wykonanymi dla cyklonu ze standardowym wlotem.

Słowa kluczowe: odpylanie, odpylacz cyklonowy, spadek ciśnienia, skuteczność odpylania, symulacje CFD

DOI:

* DSc. Eng. Ryszard Wójtowicz, Institute of Thermal and Process Engineering, Faculty of Mechanical Engineering, Cracow University of Technology.

** M.Sc. Eng. Paweł Wolak, Mechanical Equipment Department, Air Liquide Global E&C Solutions Poland S.A.

1. Introduction

The cyclones are commonly used in industry, process engineering and environmental protection for separation of solid particles from dusty gases, and also as a separation device in pneumatic transport systems [1, 2]. It is worth noting that apparatuses of this kind – despite a seemingly simple design – are characterised by complex and difficult-to-describe gas flow, resulting from simultaneously coexistence two opposite directed gas streams. The performance of a cyclone (its dedusting efficiency, pressure drop, reliability, etc.) is strongly influenced by its geometry and dimensions. Even a slight change of these parameters may result in a change of the dedusting efficiency and the creation of undesirable phenomena, e.g. a gas flow directly from an inlet channel to the outlet (short circuit) or unfavourable for dust removal process transferring of gas motion to a dust chamber.

A useful tool for cyclone design and optimisation seem to be simulation packages, based on codes of Computational Fluid Dynamics (CFD) [3]. They allow preliminary quick analysis of gas flow inside a cyclone and easy modification of its dimensions and geometry, without having to build costly prototypes and to conduct time-consuming experimental investigations.

This work verifies an idea [4] concerning the improvement of cyclone performance by an angular arrangement of a wall of the inlet channel. It should result in directing the dusty gas stream closer to a cyclone wall, putting it faster in a swirl motion, reduction of particles bouncing from a wall and unfavourable particles entrainment by a clean gas in an outflow. Analysis was carried out using CFD modelling. The results were compared to those obtained from simulations and lab-measurements for a cyclone with a standard inlet.

2. Experimental

Cyclones used in numerical investigations are shown in Figure 1. The diameter of the cylindrical part was always $D = 0.192$ m and the total height of the cyclone $H = 0.745$ m. The height of the cylindrical part was $h = 0.242$ m. The diameter and length of the vortex finder were $D_e = 0.09$ m and $s = 0.140$ m, respectively. The diameter of the cyclone at the end of the conical part was chosen to be $B = 0.045$ m. Three different gas inlets were tested. One of them was a standard, square cross-sectional with dimensions $a = b = 0.042$ m (Fig. 1b), two modified by an angular arrange of the inlet channel wall at an angle $\alpha = 2^\circ$ (Fig. 1c) and $\alpha = 4^\circ$ (Fig. 1d). Other cyclones dimensions are presented in Fig.1. Gas flowing through the cyclone was air ($\rho_c = 1.225$ kg/m³, $\mu_c = 1.7894 \cdot 10^{-5}$ Pa·s). Its velocity at the inlet of the cyclone was $u = 15$ m/s. The density of solid particles was $\rho_s = 2700$ kg/m³. The dispersed phase volume fraction was relatively low, less than 5%. During simulations, it was assumed that particle size distribution is characterised by the Rosin-Rammler theoretical distribution. The analysis of flow was performed based on results of numerical modelling, using as a pre-processor the mesh generator *Gambit 2.4* and as a solver *Ansys Fluent 14.0*. Turbulent gas flow in the cyclone was described using the Navier-Stokes equations of mass and momentum transport, averaged by Reynolds method (RANS) [5]. As a closing method, the RNG (Renormalisation Group) [3, 6] $k-\varepsilon$ turbulence

model was selected with an additional option of the Swirl Modification [7], taking into account a vorticity nature of flow inside the cyclone. To simulate the motion of the discrete phase (particles), the Euler-Lagrange (EL) [8] approach was used.

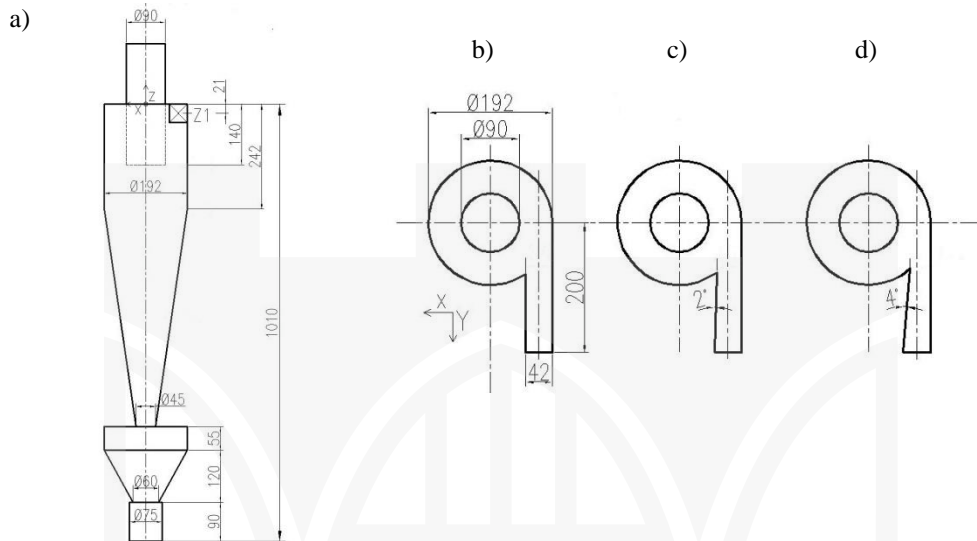

Fig. 1. The cyclone examined a) a view, b) standard inlet $\alpha = 0^\circ$, c) modified inlet $\alpha = 2^\circ$, d) modified inlet $\alpha = 4^\circ$

Detailed information on the cyclone design and methodology of simulations is presented elsewhere [9, 10]. These papers also present comparisons of the standard cyclone simulations with theoretical models and measurements, which confirm that the used numerical model is correct.

3. Results and discussion

Figure 2 presents contour and vector maps of the flow pattern in the cyclone. An angular arrangement of a cyclone inlet makes that a gas delivered is inclined toward a cyclone wall with a sudden narrowing of a stream. Dusty gas starts to rotate with high tangential velocities, of which maximum values for an inlet channel angle $\alpha = 0^\circ$ (Fig. 2a), $\alpha = 2^\circ$ (Fig. 2b) and $\alpha = 4^\circ$ (Fig. 2c) are higher in comparison with an inlet velocity ($u = 15$ m/s) by 30%, 42% and 65%, respectively. This tendency observed already in a cyclone with a standard inlet [9, 10] is significantly intensified by an angular arrangement of an inlet. It can cause an increase of cyclone dedusting efficiency. Besides, in a cyclone with an aslant shaped inlet, solid particles are supplied closer to the cyclone wall and they are faster introduced into rotational motion. It largely reduces their bouncing from a wall and eliminates their flow directly to the gas outlet stream.

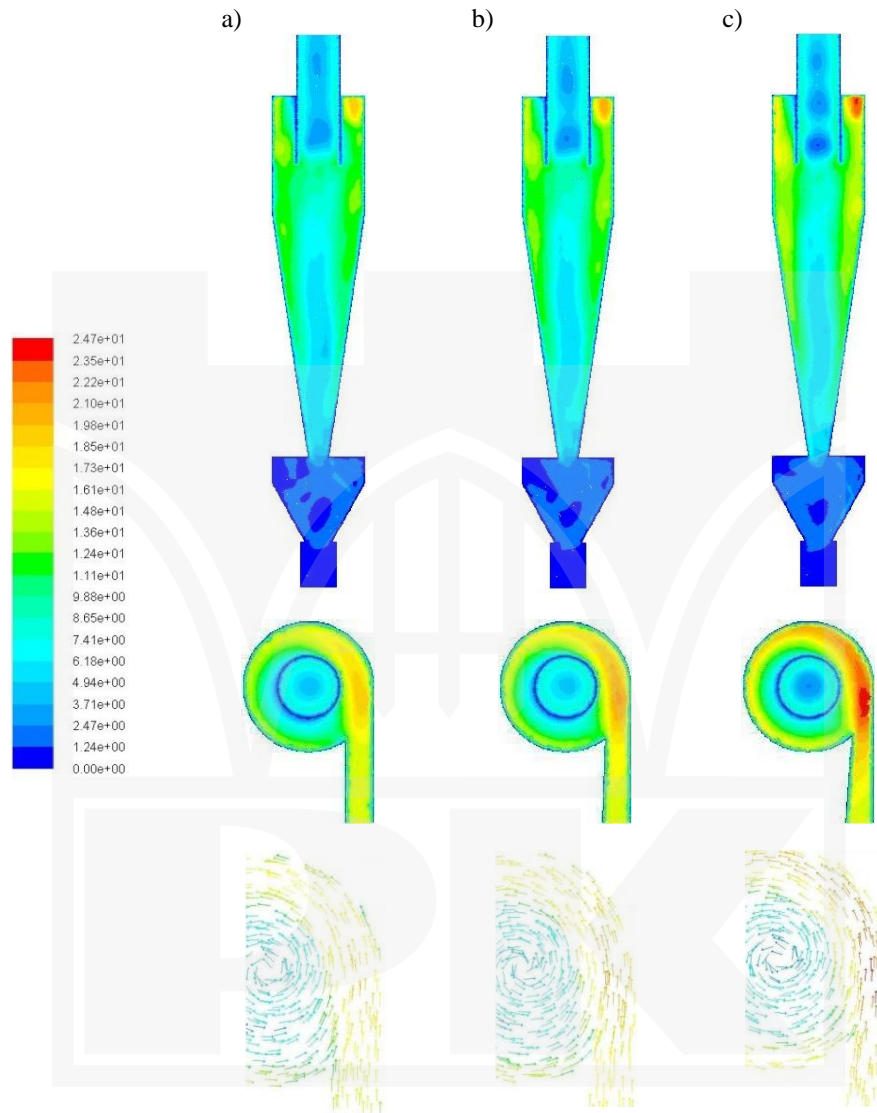

Fig. 2. Contour and vector maps of flow pattern: a) standard inlet $\alpha = 0^\circ$, b) modified inlet $\alpha = 2^\circ$, c) modified inlet $\alpha = 4^\circ$

Figure 3 presents the trajectory of the selected particle ($d_p = 2 \mu\text{m}$), which is supplied to the cyclone with a dusty gas stream. In the cyclone with a standard inlet (Fig. 3a), a particle of this size will not be dedusted. After several rotations in a swirl gas stream, a particle enters an outflow and leaves the cyclone. In cyclones with modified inlets (Fig. 3b and Fig. 3c), trajectories of particle in the cyclone upper part are larger in diameter. Polluted gas in this part has a proper velocity and particles are separated.

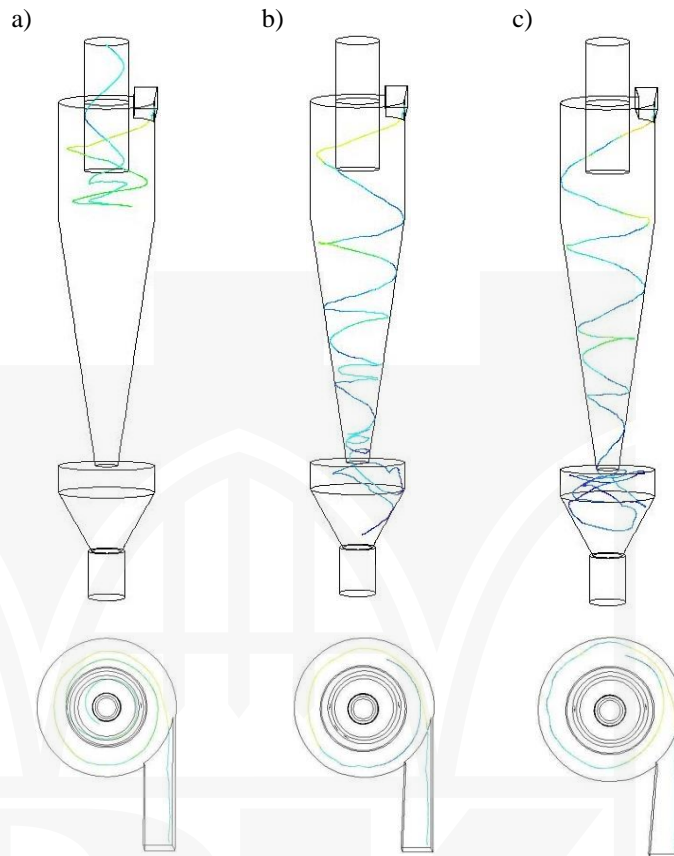

Fig. 3. Trajectories of a dust particle ($d_p = 2 \mu\text{m}$): a) standard inlet $\alpha = 0^\circ$, b) modified inlet $\alpha = 2^\circ$, c) modified inlet $\alpha = 4^\circ$

The above-described phenomena and mechanisms are confirmed by data presented in Table 1. Predicted cyclone efficiency, estimated on the basis of a classic relation:

$$\eta = \frac{m_s}{m_i} \cdot 100\% \quad (1)$$

(m_s is a mass dedusted (collected) particles, and m_i is the mass of all particles supplied to a cyclone with a polluted gas) increases for both modified inlets ($\alpha = 2^\circ$ and $\alpha = 4^\circ$) by 1.3% and 3% respectively.

On the other hand, it should be noted that for cyclone performance estimation, a second parameter – the pressure drop – should be taken into account. This parameter, in addition to efficiency, also decides on the cost-effectiveness of the process and its expenditures. In Table 1, predicted pressure drops are also presented. With respect to the cyclone with a standard inlet, they increase by 20% ($\alpha = 2^\circ$) and 32.6% ($\alpha = 4^\circ$).

Table 1

Pressure drop and dedusting efficiency for examined cyclones

Cyclone	Pressure drop [Pa]	Dedusting efficiency [%]
Standard inlet ($\alpha = 0^\circ$)	313	86.3
Modified inlet ($\alpha = 2^\circ$)	376	87.4
Modified inlet ($\alpha = 4^\circ$)	415	88.9

In the literature, there are not any uniform criterion linking these two parameters and evaluating of cyclone efficiency together. In general, the leading parameter determining the cyclone choice is the dedusting efficiency. These CFD simulations show that modification of a cyclone inlet by an angular arrangement of its wall is fully justified.

References

- [1] Hoffmann A. C., Stein L. E., *Gas cyclones and swirl tubes – principles, design and operation*, Springer - Verlag, Berlin 2008.
- [2] Warych J., *Gas cleaning*, WNT, Warsaw 1998 (in Polish).
- [3] Jaworski Z., *Computational fluid dynamics in chemical engineering*, Exit, Warsaw 2005 (in Polish).
- [4] Mieszkowski A., Roszak Z., *Environment protection systems*, Cracow University of Technology, Cracow 2010 (in Polish).
- [5] Pope S.B., *Turbulent flows*, Cambridge University Press, Cambridge 2013.
- [6] Wójtowicz R., Lipin A.A., Talaga J., *On the possibility of using of different turbulence models for modeling flow hydrodynamics and power consumption in mixing vessels with turbine impellers*, Theoretical Foundations of Chemical Engineering, 48, (4), 2014, 360-375. DOI: 10.1134/S0040579514020146
- [7] Ansys Inc., *Ansys Fluent theory guide*, Canonsburg 2011.
- [8] Andersson B., Andersson R., Hakansson L., Mortensen M., Sudiyo R., van Wachem B., *Computational fluid dynamics for engineers*, Cambridge University Press, Cambridge 2012.
- [9] Wójtowicz R., Wolak P., *Identification of multiphase flow in a cyclone separator*, International Scientific and Technical Conference “Problems of Resources and Energy Saving Technologies in the Industry and Agricultural Complex (PRET-2014)” (Monograph, W.N. Bliczew, ed.), ISUCT, Iwanowo, Russia 2014, p. 252-264 (ISBN 978-5-9616-0494-8).
- [10] Wójtowicz R., Wolak P., *An example of the use of computational-fluid-dynamics analysis for simulation of two-phase flow in a cyclone with a tangential inlet*, Environment Protection Engineering, 4, 2016 (in press).