

Andrzej Legendziewicz  orcid.org/0000-0002-9228-296X
andrzej.legendziewicz@pwr.edu.pl
Faculty of Architecture, Wrocław University of Technology

SELECTED CITY GATES IN SILESIA – RESEARCH ISSUES¹

WYBRANE ZESPOŁY BRAMNE NA ŚLĄSKU – PROBLEMATYKA BADAWCZA

Abstract¹

The conservation work performed on the city gates of some Silesian cities in recent years has offered the opportunity to undertake architectural research. The researchers' interest was particularly aroused by towers which form the framing of entrances to old-town areas and which are also a reflection of the ambitious aspirations and changing tastes of townspeople and a result of the evolution of architectural forms. Some of the gate buildings were demolished in the 19th century as a result of city development. This article presents the results of research into selected city gates: Grobnicka Gate in Głubczyce, Górna Gate in Głucholazy, Lewińska Gate in Grodków, Krakowska and Wrocławskie Gates in Namysłów, and Dolna Gate in Prudnik. The obtained research material supported an attempt to verify the propositions published in literature concerning the evolution of military buildings in Silesia between the 14th century and the beginning of the 17th century. Relicts of objects that have not survived were identified in two cases.

Keywords: Silesia, architecture, city walls, Gothic, the Renaissance

Streszczenie

Prace konserwatorskie prowadzone na bramach w niektórych miastach Śląska w ostatnich latach były okazją do przeprowadzenia badań architektonicznych. Zainteresowanie badaczy budziły zwłaszcza wieże, które tworzyły wejścia na obszary staromiejskie, a także były obrazem ambitnych aspiracji i zmieniających się gustów mieszczan oraz rezultatem ewolucji form architektonicznych. Niektóre budynki bramne zostały rozebrane w XIX wieku. W artykule przedstawiono wyniki badań wybranych bram miejskich: Brama Grobnicka, Głubczyce, Brama Górna, Głucholazy, Brama Lewińska, Grodków, Brama Krakowska i Wrocławskie, Namysłów i Brama Dolna, Prudnik. Uzyskane materiały naukowe stanowiły materiał wyjściowy dla próby zweryfikowania propozycji opublikowanych w literaturze, o ewolucji architektury militarnej na Śląsku między XIV a początkiem XVII wieku. Ponadto przebadano relikty dotychczas nieznanymi dwóm bram miejskich.

Słowa kluczowe: Śląsk, architektura, mury miejskie, gotyk, renesans

¹ The article presents the results of research into Grobnicka (Monastic) Gate in Głubczyce, Górna Gate in Głucholazy, Lewińska Gate in Grodków, Krośnińska and Głogowska Gates in Kozuchów, Krakowska and Wrocławskie Gates in Namysłów and Dolna (Karniowska) Gate in Prudnik.

1. Introduction

The foundation of cities in Silesia started in the first half of the 13th century with the effort undertaken by Duke Henry the Bearded and the many continuators who followed after his death in 1238. The process was supported by Czech kings, local Silesian princes, and also bishops and other powerful individuals. City charters and the foundation of cities put the issues of local administration and judiciary in order, and also created a settlement network with commercial, economic as well as military importance.

Therefore, it is not surprising that this process was especially intensive in the insecure borderland between Silesia and Czechia, where probably before 1249 a city charter was granted to Głuchołazy [63, No. 380], and before 1253 also to Głubczyce [53, pp. 32–3]. A similar situation occurred on Silesia's western frontiers, where Kozuchów was founded before 1253 [29, pp. 18–21]. Mroczo of Pogorzele probably accounted for the foundation of Grodków before 1250 [20, pp. 89–93], whereas Henry of Rozmberk accounted for the foundation of Prudnik in about 1279 [64, pp. 73]. Before 1278, a city charter was granted by Duke Henry IV Probus (the Righteous) to Namysłów [35, p. 23].

The establishing of a city center was marked by the erection of buildings that were necessary for a city's operation: a town hall (the seat of municipal authorities), a parish church, and a circuit of walls with gates. These structures, together with houses and bourgeois buildings, created the characteristic panoramas of Silesia's cities. This landscape remained mostly unchanged almost until the end of the 18th century, after which the military function of city walls was gradually reduced due to the evolution of military engineering initiated by the introduction of firearms. With the rapid economic and urban development of these cities in the 1st half of the 19th century came the gradual removal of elements that conflicted with and restricted transport – *inter alia* city gates and certain stretches of walls.

The value of Silesia's medieval military architecture was noticed at the end of the 19th century, when the towers of Grodków [22, pp. 21–22], Głuchołazy [24, pp. 21–22] and Prudnik [25, p. 58] were subjected to repair works for the first time. Unfortunately, the works not only caused the original forms and details to be covered up, but they also distorted historic shapes with the introduction of new elements. Observations made while the works were being carried out served German researchers as the basis for initial propositions about the construction and evolution of gate objects in Silesia². However, these theses could not be confirmed and therefore the towers and walls have since been presented in the literature as they were perceived at the end of the 19th century or at the beginning of the 20th century. Also, restoration works were based on the results of the same research [34, 36, 37, 39, 42, 43, 44]. The scope of the works included not only analysis of the gates themselves or retained relicts thereof, but also preliminary iconographic and source research. The results of the research constituted the initial material for conservator's conclusions that formed the basis for restoration designs or for the exposure of these objects.

² See: the state of research presented in the description of each of the gates.

In spite of their common origin, the gates presented herein differ in time of construction, phases of transformations, present condition and historic sources. This article presents gate objects situated in several of Silesia's cities. It seems advisable to discuss each of the objects in detail, together with studies and the results of architectural research and reconstruction studies, if any.

2. Głubczyce – Grobnicka (Monastic) Gate

The circuit of medieval city walls in Głubczyce, first mentioned in 1282, consisted of a stone curtain with nineteen towers and three gates [6, p. 34, 110; 5, p. 128; 55, pp. 36–37; 67, pp. 10–11]: Górna (Nyska) Gate from the north, Dolna (Opawska) Gate from the south and Grobnicka (Monastic) Gate from the east. Probably in the 14th and 15th centuries, the three gateways were strengthened with foregates and Górna and Grobnicka Gates were made higher and covered with high tent roofs, as can be seen in a city panorama by Fryderyk B. Werner that dates back to about 1738. The development of siege techniques which used firearms involved the modernization of the towers at the beginning of the 17th century. Probably at this time the octagonal part was built on top of Opawska Gate and crowned with an attic comb, whereas a storey with pilasters was added on top of the semi-circular towers in the southern segment and covered with masonry cupolas. The demolition of the walls started with a royal order dated 1764 [54, p. 240]. The levelling of the curtain started at the end of the

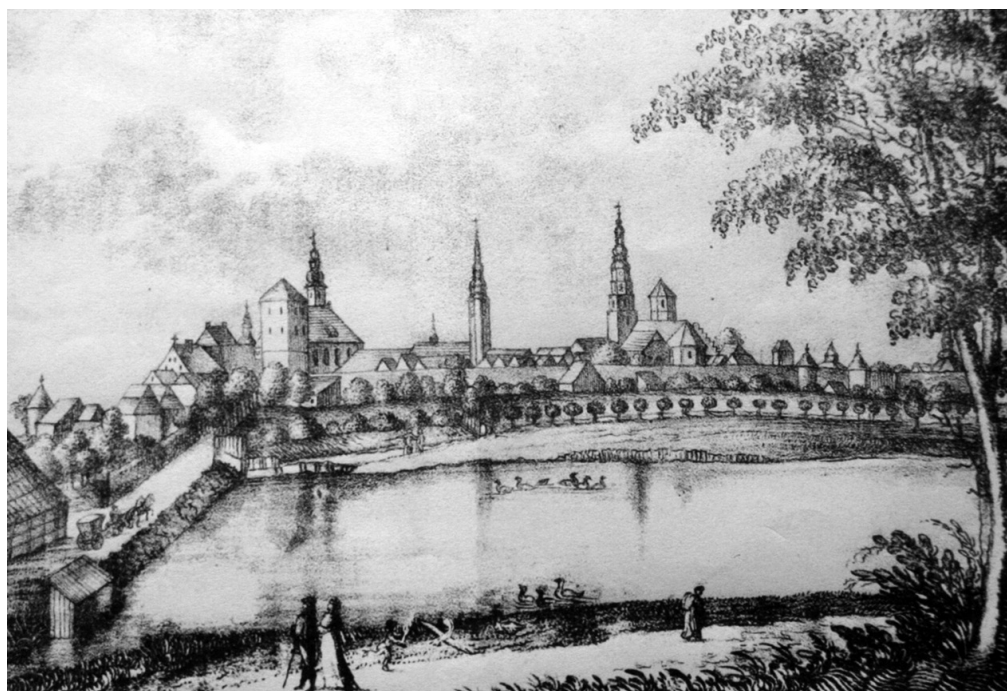

Fig. 1. Głubczyce, panorama of the city from the east from the beginning of the 19th century – Grobnicka Gate, first on the left (a drawing from the collection of the Poviát Museum in Głubczyce)

18th century, whereas Górna (Nyska) Gate was demolished in 1830 [18, p. 77; 52, p. 240]; six years later Dolna (Opawska) Gate was demolished [18, p. 77; 54, p. 241], as was Grobnicka Gate in 1853 [18, p. 77; 54, p. 241].

The oldest source entries that mention the city walls date back to 1282 [6, p. 34, 110; 5, p. 128; 55, pp. 36–37; 67, pp. 10–11;] and 15 April 1298 [67, p. 12; 59, pp. 193–203; 55, pp. 124–5]. The city gates were mentioned several times as reference points in the deeds of sale of nearby properties. Dolna (Opawska) Gate was mentioned in 1383 in a sale of land deed by Duke Mikołaj [55, p. 235] and in 1388 in the deed of sale of the city mill [67, p. 24]. The deed of purchase of a castle situated near Górna Gate [55, p. 175] is dated 10 January 1565.

The subject of the Głubczyce fortifications has been raised in the literature a number of times: German and Polish authors did not describe the walls with enough precision; they cited the oldest source documents, and according to them the wall's construction dated back to the 13th century, while the extension dated back to the turn of the 14th and 15th centuries [55, pp. 124–125; 6, p. 132; 67, p. 24; 50, pp. 173–174; 5, pp. 128; 31, p. 60; 12, p. 1–9; 21, p. 28–29; 14; 58, p. 24; 61, p. 178; 59, pp. 193–203; 52, pp. 159–167; 53; 58, p. 61]. A city gate review quoting the gate names was first published by Robert Hofrichter, who superficially described

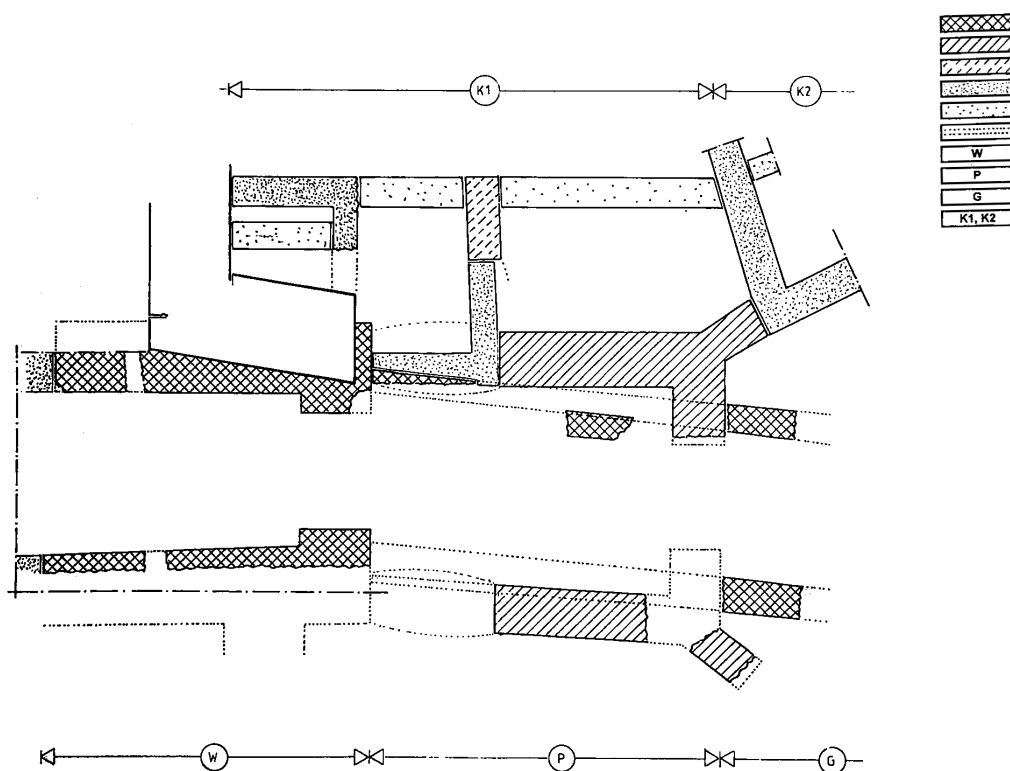

Fig. 2. Głubczyce, Grobnicka (Monastic) Gate, projection of fundaments with chronological wall stratification.

A – 1st half of the 14th century; B – 2nd half of the 14th/1st half of the 15th century; C – Renaissance; D – Baroque; E – 19th and 20th century; W – tower; P – foregate, G – dam; K1, K2 – tenement houses

(drawn by A. Legendziewicz)

the gate architecture and furnishings [18, p. 72]. An analysis of the architectural form of the city walls was presented by Barbara Piechaczek [56, p. 19] based on the street map produced by A. Plasqude in 1770 and on a panorama produced by F.B. Werner in the middle of the 18th century. Propositions about the formation of all the gates and walls were included by the same author in her doctoral thesis [57, pp. 33–65]. These propositions about the development of Grobnicka Gate could be reviewed based on research undertaken in 2012 [43].

The original gate tower was probably erected at the turn of the 13th and 14th centuries on almost 2-metre-wide foundations laid on an 8.5/8.9-metre rectangle-like plan. The continuous footing was laid in layers in narrow-spaced trenches with the application of dark slate stone, in shades ranging from graphite to grey. To the east, the approx. 3.2-metre-wide gateway clearance along the east–west axis was narrowed with gate frames that were probably semi-circular in shape. However, from the city side, the tower interior was open without any narrowing. The archive gate view produced by F.B. Endler in about 1800 showed that the tower had an offset at a height of about 10 meters above ground level, which may indicate the hoarding level. The eastern façade surface was broken by a high lancet recess filled with a portcullis. Unfortunately, no relicts of runners were found within the uncovered foundation walls.

To the east, the gate tower was preceded by a probable masonry causeway that was about 5.7 meters in width and tilted slightly to the south from the gateway axis. The wall segments, which were built with a technique similar to that in the tower, formed the grounds for the restoration of the causeway length, which seems to be over 12 meters.

The entrance to the city was strengthened – probably at the turn of the 14th and 15th century – by the construction of a foregate that was built on an 8/10-metre rectangle-like plan. The walls were built on foundations that were made of slate sandstone, irregularly laid on a rather hard, cream-colored lime and sand mortar. The continuous foundations of both the approx. 1.5-meter-wide side walls were laid in a narrow-spaced trench and were shifted away from the tower by about 3.5 meters. Over that space there were probably arch stretches resting on the tower and foregate foundations. The neck corners were strengthened in the east with obliquely positioned buttresses. The relicts that survived have confirmed that the width of the gateway clearance could have been about 3 meters. It should be noted that the gateway was situated along the causeway axis, and that the causeway walls were precisely cut to construct the east walls of the foregate.

3. Głucholazy – Górna Gate

The ellipse-like circuit of walls in Głucholaz included two gates: Górna Gate and a tower in the south, and Dolna (Nyska) Gate in the north. Due to the evolution of military techniques, the walls were modernized at the beginning of the 17th century and kept ready for use almost until the end of the following century [24, pp. 21–22]. The wall levelling started in 1834 after a city fire, and four years later Dolna Gate and the tower were demolished [31, p. 86]. In 1860, the gateway body of Górna Gate was demolished and only the tower remained [31, p. 86]. Except for the tower, only two small segments of the medieval fortification walls survived:

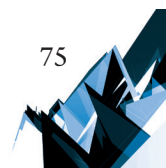

one in the north-western corner of the chartered city (located under a foundation charter), and the other on the east side, near the building of the former office of governor.

Due to the very few remnants that survived and the very modest source material, the earlier researchers' interest in Głucholazy fortifications was low. Hans Lutsch was the first to describe the tower; he stated that it was erected during the Renaissance in about 1600 under the influence of Italian architecture, as was the case with the church towers in Boguchwałów and Witoszów, the parapets in the castle of Bolków, the church in Paczków, the tower of Wrocławska Gate in Nysa and Ziębicka Gate in Grodków [51, p. 187, table 188/6; 50, p. 145]. On the basis of this information, Paul Kutzer indicated governor Adelsbach as the founder of the building in his monograph on Głucholazy [31, p. 86]. The description of the stone tower crowned with an attic comb, with palmettes and blind windows beneath, was supplemented with a print made by Arthur Blaschnik in about 1860 [31, p. 87]. Polish researchers unanimously commented on the development of the tower's architecture. T. Chrzanowski and M. Koniecki indicated the second half of the 14th century as the time when the tower was built [24, pp. 21–22]. Based on the dates shown on the former town hall's spire element on the cupola, they stated that in 1631 the tower was converted to the Renaissance style and in 1795 it was repaired in the Baroque style [24, pp. 21–22]³. This concept was uncritically repeated by Józef Pilch [58, p. 63]. The conservation works performed in 2008 enabled the researchers to carry out architectural research on the tower and make an attempt to verify the propositions about the tower's transformations that had been published in the literature [39; 40, pp. 11–113; 41, pp. 84–89].



Fig. 3. Głucholazy, panorama of the town from the south, around 1738 by F.B. Werner – Góna Gate's tower No. 4 (drawing from the collections of the University Library in Wrocław)

³ The tower finial ensign shows the years 1631 and 1795; it comes from the tower of the Głucholazy town hall and was put onto the tower in question during the 1899–1902 repair works [31, p. 97].

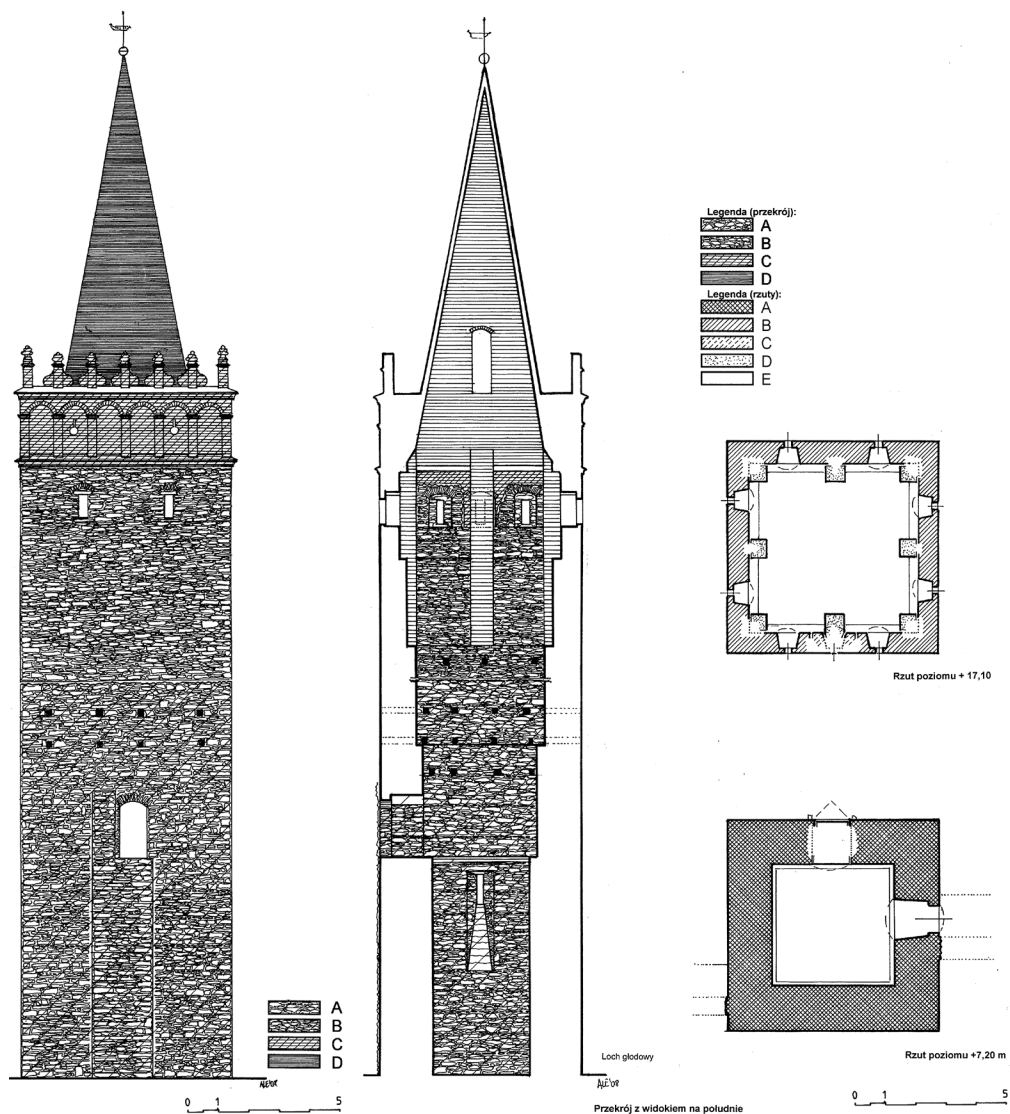

Fig. 4. Glucholazy, Górna Gate's tower, east elevation, cross-section with a view to the south and projections with chronological wall stratification. Elevation and section. A – 1st half of the 14th century, B – 2nd half of the 15th century; C – around 1600; D – between 1898–1902; projections Signs: A – 1st half of the 14th century; B – 2nd half of the 15th century; C – around 1600; D – between 1898–1902, E – unrecognized walls (drawn by A. Legendziewicz)

The tower at the outlet of Basztowy square was built on a 7.4/7.2-meter square-like plan. Its approx. 23-metre-high facades are made in stone without plaster, crowned with a two-storey parapet which consists of six semi-circular alcoves separated with pilasters in its lower part. The pilasters are the resting points for a protruding cornice, which forms the base of an attic consisting of seven pillars with palmettes, of which the five middle ones

encompass five pairs of volutes. A brick pyramid cupola, almost 11 meters in height, rises from behind them.

The lower sections of the tower base – up to 13 meters in height and constructed from slate stone – date back probably to the first half of the 14th century. They include another tower, almost the entire height of which survives, with relicts of a wooden finial structure inside, two entrances and a narrow window. The tower was built together with a gateway on its east side. The part made of crushed stone laid in layers on a 7.4/7.2 meter square-like plan was about 13 meters high – probably one storey higher than the curtain. The tower façade was plastered – probably due to the material that had been used for construction and the building technique applied. The finial was probably formed as a hoarding running around the wall crown on the east, south, and west. It was installed on wooden brackets mounted in the wall at a height of about 12 meters above the present ground level. The whole structure was probably covered with a short-ridged tent or hip roof. A rectangular entrance opening with a triangular head led to the inside from the city side. It was located in the northern façade at a height of about 7.2 meters above ground. A wooden platform supported by stone brackets near the opening probably linked that opening to a fortified porch on the curtain near the south-western corner of the tower. The other opening was located on the eastern façade and led to the top of the wall above the gateway.



Fig. 5. Glucholazy, Górna Gate's Tower – view from the south (photo by A. Legendziewicz)

The interior was divided into three storeys, probably with beamed ceilings on wall offsets and pockets. On the lowest floor there was a dungeon, which was accessible through a ceiling hole and lit in the south via a narrow window with a step-like downstream apron and an overlapping stone-tile window head. The storey above the dungeon was accessible through the entrances mentioned above. The two storeys above this were accessible by ladder.

The city of Głucholązy was captured by the Hussites on 20 March 1428 [32, pp. 45–46]. It is likely that the church, buildings and also Górna Gate tower were damaged during the siege. The slow process of the reconstruction of the city and the walls led Wrocław Bishop Jodok to exempt the inhabitants from paying rent in 1463 [1, Deeds of the city of Głucholązy, File No. 112]. Therefore it is probable that the reconstruction of the tower was completed in the second half of the 15th century. The walls from that period were built in the upper part of the tower body to a height of about 20 meters above the present ground, or even higher due to later conversions. Narrow firing ports were located at a height of 18.3 m – three in the south, and two in each of the other façades. The division of the interior into storeys is marked by offsets at heights of about 14.20 m and 17.00 m.

The conversion of the tower involved a change in the shape of the tower. It is likely that the damaged copula and hoarding were demolished and the tower itself was made higher. The shape of the new finial remains unknown. The plastered façades were made aesthetically pleasing and were interrupted only by narrow rectangular firing ports. Relief arches made of arch stones were installed over each of the ports and the façade was plastered. The two entrance openings that had led to the tower survived and the internal layout was not subjected to significant modifications. The dungeon remained on the lowest floor. At least two new ceilings were built that rested on offsets and were accessible by ladder.

The Gothic tower was subjected to conversion in the Renaissance style probably at the end of the 16th century and the beginning of the 17th century. An attic and a new architectural décor were introduced on the façades; the color scheme consisted of grey and black on details with red palmettes and Roman white plastering. The works in Głucholązy could have been funded by governor Henrich Adelsbach, who also introduced a new style to his office building at the beginning of the 17th century [41, pp. 76–96].

4. Grodków – Lewińska Gate

The Gothic circuit of walls in Grodków was marked out on a very regular, almost circular plan and included four gates: Wrocławska (Brzeska) Gate in the north, Nyska Gate in the south, Ziębicka (Strzelińska) Gate in the west and Lewińska Gate in the east. The walls and towers erected in the second half of the 14th century were probably damaged by the Hussites in 1428 [1, Deeds of the city of Grodków, File No. 1273]. The circuit was subjected to modernization probably in the 15th century, and the two towers of Lewińska and Ziębicka Gates were modernized before the end of the 16th century [22, pp. 21, 22]. In 1825 in Grodków, as in other cities, the circuit was partly levelled, the moat was backfilled, and

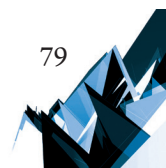

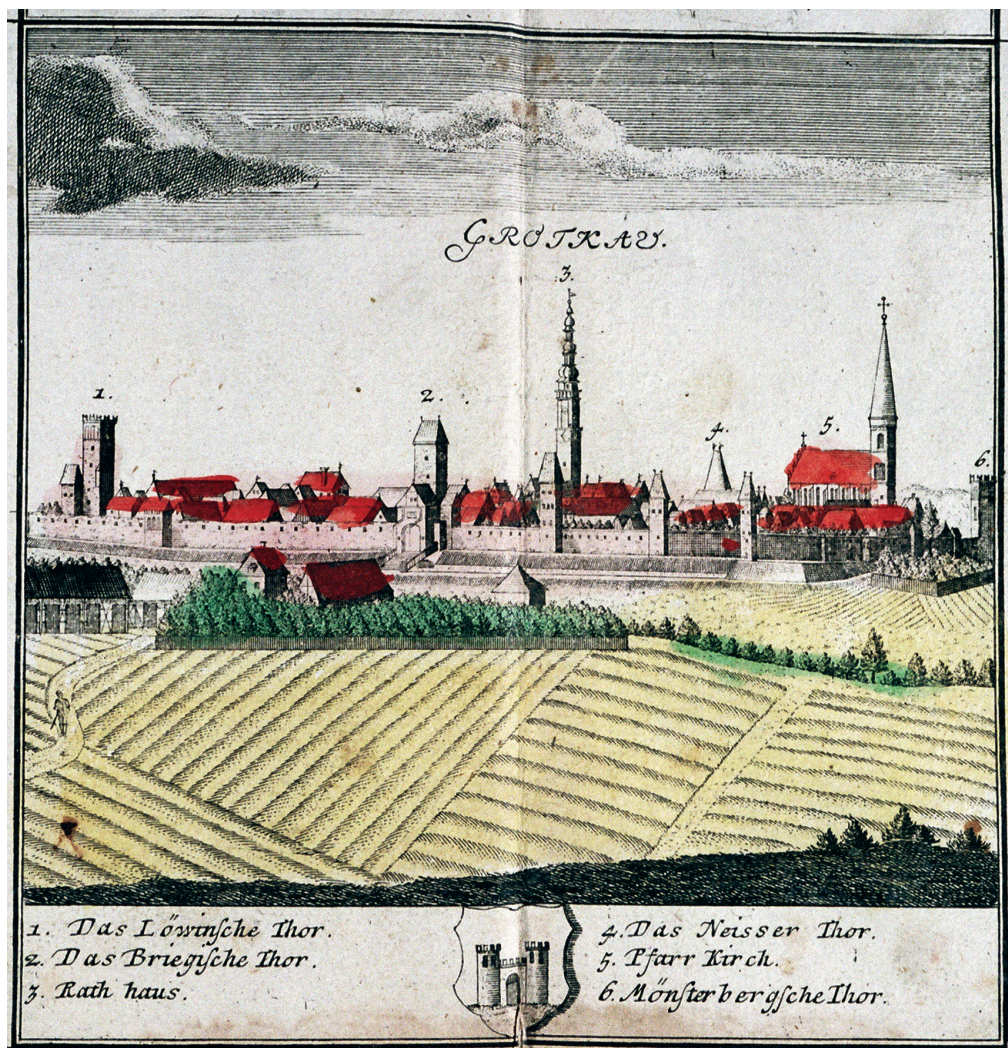

Fig. 6. Grodków, panorama of the town from the north around 1738 by F.B. Werner – Lewińska Gate No. 1
(drawing from the collections of the University Library in Wrocław)

Wrocławska and Nyska gates and stretches of the walls in the north-west and south-east were demolished [33, 22, p. 21].

The oldest mention of the walls of Grodków concerns Wrocławska (Brzeska) Gates and dates back to 1282 [8, File No. 1578]. The walls are also mentioned in a document from 1411 in which Wrocław Bishop Waclaw expressed his consent to the construction of a mill within the walls [1, Deeds of the city of Grodków, File No. 1255]. The other city gate, Ziębicka, is mentioned in the deed from 1463 in which a garden in front of the gate is mentioned [1, Deeds of the city of Grodków, File No. 1280]. The City Chronicles of 1867, in which historic notes on the construction of walls around the city by the Duke of Jawor, Bolko I the Strict

[10, p. 21] are mentioned, should be given consideration. A description of the walls and information on the porch traces were published by H. Lutsch [50, pp. 50, 51]. On the basis of the City Chronicles entries, Marian Kutzner [33], T. Chrzanowski and M. Koniecki [22, pp. 21, 22] stated that Duke Bolko I the Strict funded the medieval walls in the years 1296–1301. The modernization of the city fortifications in about 1350 consisted of making the curtains higher and the erection of the towers and Wrocławska (Brzeska), Nyska, Ziębicka and Lewińska gates, presumably by the Przeclaw of Pogorzele, the Bishop of Wrocław. These researchers dated the conversion of the tower finials for Ziębicka and Lewińska Gates and the construction of the parapet to about 1600. In their opinion, the medieval fortifications were probably repaired after the Thirty Years' War in the years 1664–71 on the initiative of Bishop Sebastian von Rostock, whereas the backfilling of the moats and the demolition of the walls and two city gates started in about 1825 [33, pp. 8, 15. 26–27; 22, pp. 21, 22]. Coincident opinions on the construction of the Renaissance finials were published by Mieczysław Zlat

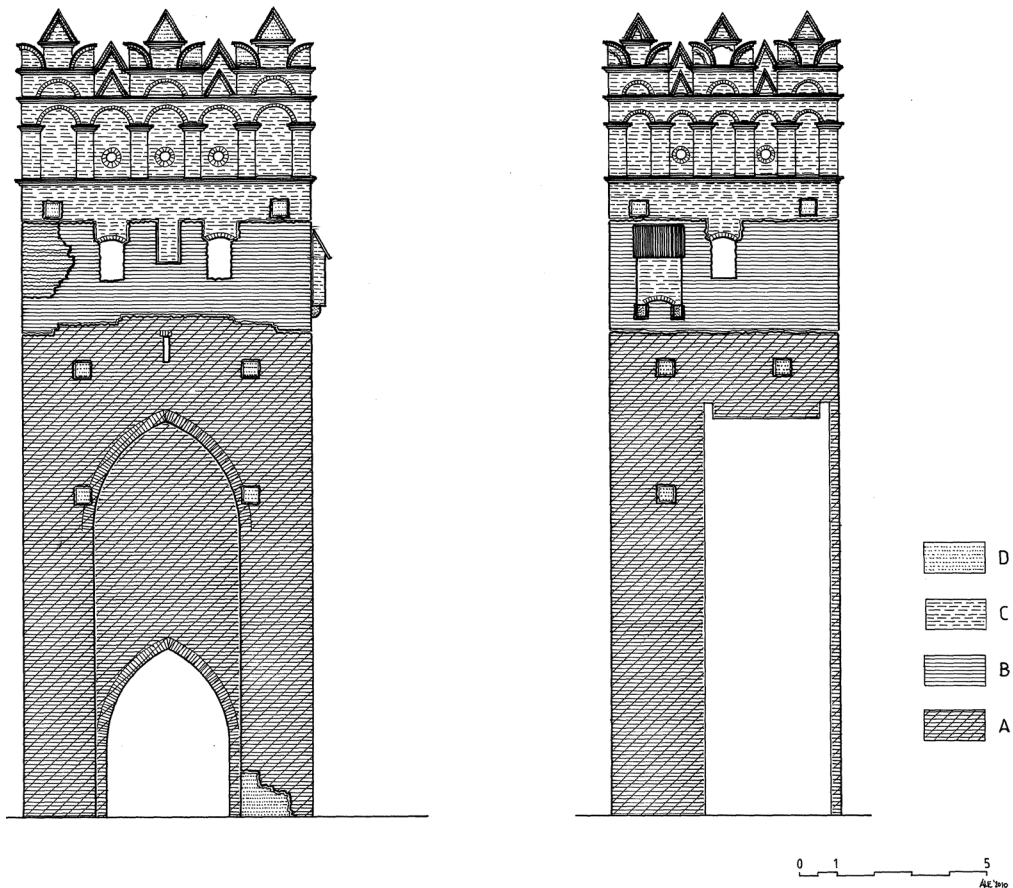

Fig. 7. Grodków, Lewińska Gate, eastern and northern elevations with chronological wall stratification. A – 2nd half of the 14th century; B – 1st half of the 15th century; C – around 1600; D – 19th and 20th centuries (drawn by A. Legendziewicz)



Fig. 8. Grodków, Lewińska Gate – view from the east (photo by A.Legendziewicz)

[69, p. 59], B. Piechaczek [57, pp. 66–81] and J. Pilch [58, p. 70]. The process of erecting the medieval walls in Grodków is viewed slightly differently by Czesław Lasota and Andrzej Legendziewicz – the authors of research carried out in 2005 [34, pp.4–8]. They stated that the note about the construction of the circuit in the years 1296–1301 probably concerned the wooden and earthen walls, whereas the present walls were constructed in stages in the second half of the 14th century. As far as the modern conversions of the gate towers are concerned, their view is consistent with the current one. These propositions were confirmed by the research carried out when Lewińska Gate was being repaired [40, pp. 108–109].

The Lewińska Gate tower is located in the east part of the circuit, at the end of Józef Elsner street. It was erected on a rectangle-like plan, with an outer outline of about 6.1/7.8 meters. In the basement, there is a 3.5-metre-wide gateway with lancet arch openings. On the eastern façade, there is a high lancet arch recess for a stylized portcullis, and on the northern façade there is a latrine bay. The tower, which is about 22 meters in height, is crowned with a parapet consisting of a strip of five arcades with three plinths on them, each with two quarter circles and a pillar with a triangular cap. Behind the comb, there is a V-roof from which the rainwater is drained via two gargoyles.

The original gate tower was built in the second half of the 14th century and has survived up to a height of about 13 meters. It was erected on a roughly 6.1/7.8-metre quadrilateral-like plan. In the basement there is gateway along the east–west axis, with lancet arch openings and a 1.5-brick-thick arch on the longer side. Above the entrance from the moat side, there is a lancet-arch recess with a portcullis and the gateway opening was closed with double gates. The inner storeys are marked out by offsets which support wooden floor beams. The first floor was accessible in the south via the entrance directly from the curtain footway. The other two floors were accessible by ladder, whereas the highest of the preserved floors was lit through two slot windows in the longer walls over the gateway openings. The finial form is unknown. The brick façade decors consisted of a two-color single-stretcher bond, with regularly arranged overburnt bricks and carefully made horizontal flat joints that are undercut at the bottom, and vertical flat joints with a groove [9, pp. 5, 6]. The brick base consisted of an 80–100 cm plinth made of erratic boulders. The façade was painted as soon as the walls were erected – numerous traces of red and white paint were found on the brick face and the joints, respectively.

The tower was probably repaired in about 1414, as was confirmed by a plate (known in the 19th century) with a date and the name *Johannes* on it [22, p. 22]. This was probably the time when the damaged upper part was demolished to a height of 13 meters above the present ground and the circuit walls were made higher by the addition of at least one storey. The interior was lit through two windows of an unknown shape which were situated along the longer walls' axes. The form of the new finial also remains unknown. The façades were most likely plastered, as is confirmed by the flat joint of the single-stretcher bonding.

Transformations in the gate tower's architecture came with the Renaissance; the tower and Ziębicka Gate tower were probably modernized at the turn of the 16th and 17th centuries. The Late Gothic finial of Lewińska Gate was demolished to the level of the upper window arches. The circuit of walls was made higher to over 22 meters and crowned with a two-storey attic. The façade was covered with smoothed plaster with a slightly uneven texture and a detail was introduced: bossage in the corners, around the portcullis recess, and on the window trims. A latrine bay supported by stone brackets was added in the north. The architectural décor was in two colors: the detail was grey and black, and the smoothed plaster was the color of natural lime.

5. Kozuchów – Krośnieńska and Głogowska Gates

The medieval fortifications of Kozuchów consisted of an almost complete double ring which encircled the chartered city. The inner ring was about 1300 meters in length, had ten towers, and was probably built in the first half of the 14th century; the outer ring was about 1000 meters in length, had at least eight fortified towers, and was probably built in the third quarter of the 15th century [45, pp. 63–73]. The northern fragment of the fortifications was strengthened by the inclusion of a castle [47, pp. 23–37]. The entrances to the city were secured with three gates: Żagańska in the west, Krośnieńska in the north-west and Głogowska

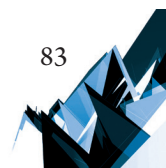

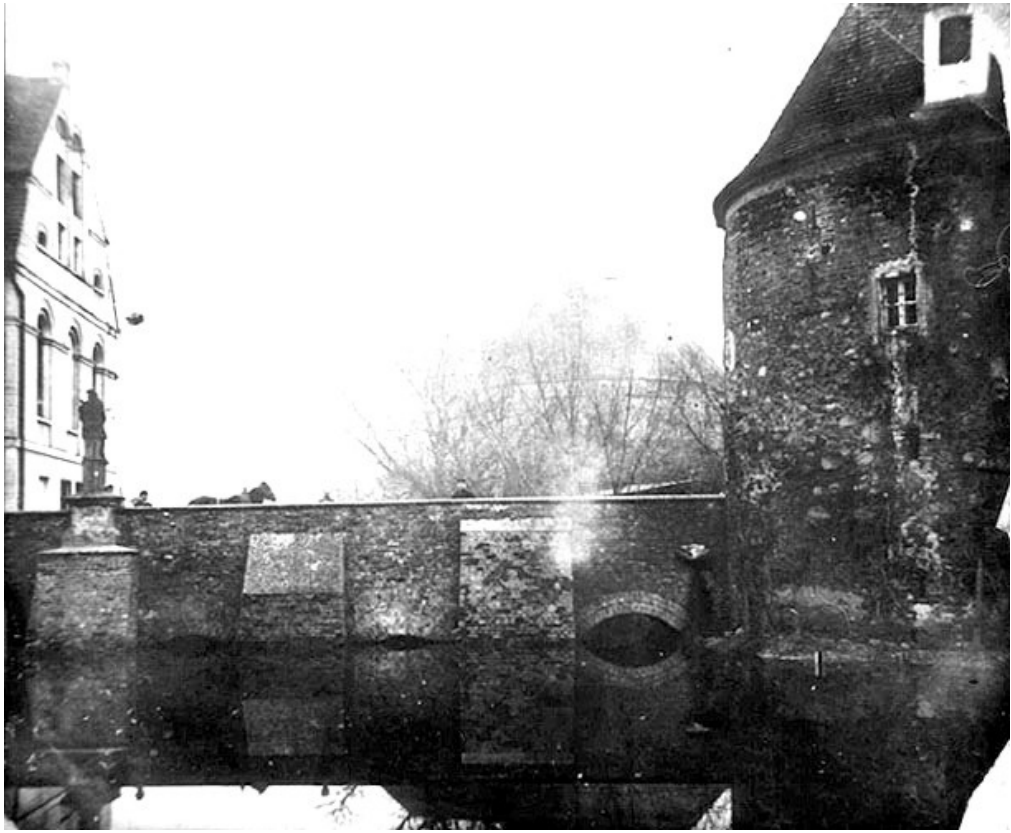

Fig. 9. Kozuchów, Krośnieńska Gate, the view of the bridge from the south, a postcard from the end of the 19th century (from the collection of Z. Szukielowicz)

in the east. In 1418 Duchess Katharina of Opole consented to the cutting of a wicket gate (*Pestpforte*) near the parish church [15, p. 43; 4, p. 51], and at the end of the 15th century or at the beginning of the following century the Szprotawska wicket was built in the southern part [4, pp. 51–53]. At the close of the Middle Ages, each of the entrances was probably protected with a tower, a gateway in the basement and a foregate – as is confirmed by the oldest street map drawn up by Christian von Wrede in 1750 and by an 18th-century view⁴ of Głogowska Gate. In Żagańska and Głogowska Gates the foregates had rectangle shapes, while in Krośnieńska Gate the foregate was elongated and resembled a horseshoe. The demolition of the fortifications probably started in 1764 after a city fire, and the gates were probably levelled at the beginning of the 19th century [4; 45, pp. 63–73]. The remnants of two of them, Krośnieńska and Głogowska, are partly presented or exposed above ground level. The remnants of the former, which consisted of the southern part of a semi-circular foregate, were subjected to conversion in the 16th and 17th centuries; the remnants of the second gate consist

⁴ I thank Zdzisław Szukielowicz for making the print available.

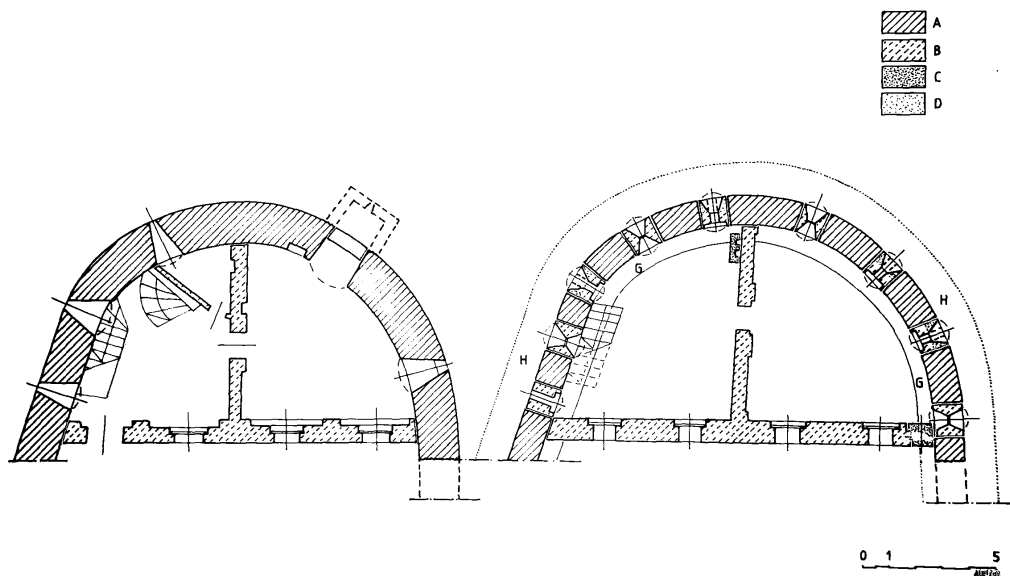

Fig. 10. Kozuchów, Krośnieńska Gate, foregate, projections of the ground level and parapet walk with chronological wall stratification. A – 2nd half 14th/1st half 15th century; B – Renaissance; C – Baroque; D – 19th and 20th century; H – hoard; G – parapet walk, W – latrine bay (drawn by A. Legendziewicz)

of the south neck wall and the outline of a tower, which is exposed as a low wall and a drawing in the roadway flooring [45, pp. 63–73]⁵.

The oldest source information on the city gates and walls of Kozuchów comes from a document issued in 1311 [19, p. 161 No. 3]. Two deeds (dated 1321 and 1412) contain information about a moat and walls [19, p. 162 No. 4, p. 170 No. 44]. Głogowska Gate was mentioned in 1433 [19, p. 132 No. 6a] and also in 1474, with the latter being a note about works on the gate and the building material used to strengthen the castle fortifications and the moat [15, p.133].

The current literature on the construction and development of medieval fortifications is based on the aforementioned source documents [26; 48; 27, pp. 235–248; 28; 66, pp. 9–13; 2; 3, pp. 66–77; 29; 13, pp. 109–118]. A summary of the state of research has been published by Tomasz Andrzejewski and Zdzisław Szukielowicz [4, pp. 5, 6]. Based on the archival source material, the authors suggested that the first circuit was built at the turn of the 13th and 14th centuries, and the construction of the outer ring took place in the period preceding the 1476–82 war of the Głogów succession [4, pp. 7–12]. Detailed architectural research into the two circuits of the medieval fortifications and the relicts of the Głogowska and Krośnieńska gates was conducted by the author of this article [42]. The research was summed up and a proposition about the construction of the inner circuit in the first half of the 15th century and of the outer circuit in the third quarter of the 15th century was set out in an article published in 2012 [45, pp. 63–73].

⁵ While carrying out the research I was assisted by Messrs M. Listwan and M. Lesiuk, whom I thank cordially.

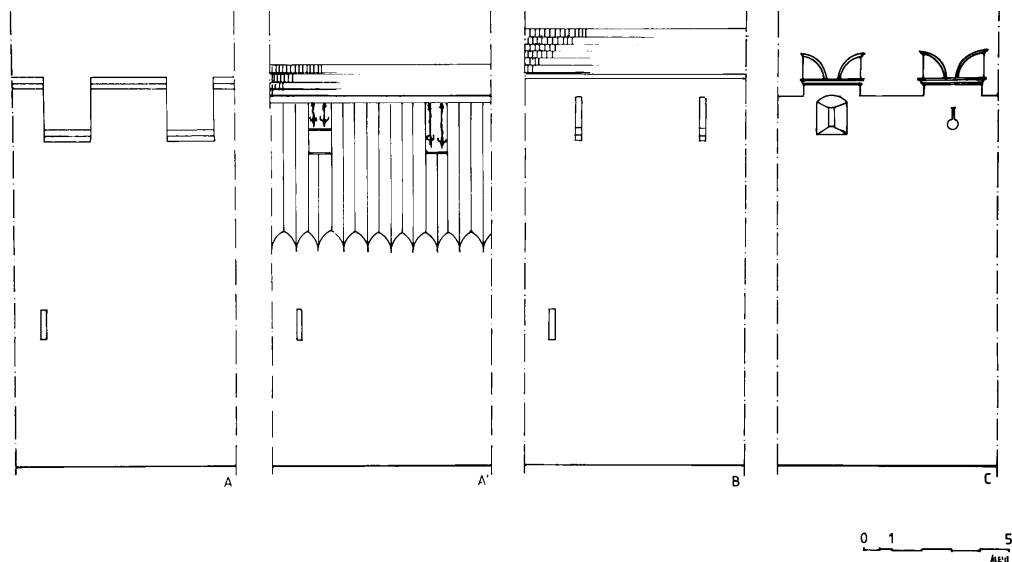

Fig. 11. Kozuchów, Krośnieńska Gate, foregate, reconstruction of the solutions of the upper part of the façade (parapet walk). A, A' – 2nd half of 14th/1st half of 15th century (crenellate and hoard); B – 2nd half of 15th century (gunports), C – Renaissance (attic and gunports (keyhole)) (drawn by A. Legendziewicz)

The construction of the wall took place in stages in the first half of the 14th century. The gates were probably built first; Krośnieńska gate was rectangular and was within the tower plan but projected out beyond the curtain face. The gateway in the basement was preceded by a bridge, whose span when lifted was about 3.2 meters long. The tower's architecture remains unknown, although one can suppose that it was crowned with crenellation, which might have been strengthened with a wooden hoarding. The gate was probably modernized over a period from the mid-14th to mid-15th century. A horseshoe-shaped foregate was built to the west of the tower at that time. A foregate wall constructed with erratic boulders was added to the circuit curtain in the south and probably to the north-western corner of the tower in the north. The entrance axis tilted in a north-westerly direction and ran along the northern wall of the foregate. The gate opening located in the north edge of the western façade was preceded by a draw-span bridge. Slot openings were situated on one level on the archwise façade in the west and south, and the wall was crowned with crenellation. The hole edges and the parapet walk breastwork, with crenellations spaced at 150–160 cm intervals, were built in brick. From the moat side, the foregate was strengthened with a wooden hoarding whose brackets were fastened in wall pockets spaced at about 110–120 centimeters. Moreover, there was a bay latrine in the west, as is documented by gate views dating back to the beginning of the 20th century.

The foregate walls were built in cobblestone interleaved with pieces of bricks, laid in layers up to a height of about 80–90 centimeters. The breastwork was built in brick, 7.5–8.5 cm/12–14 cm/26.5–27.5 cm in size, ranging in color from orange to black due to baking, with a local effusion of glaze. A similar material was applied to slot-opening reveals and embrasures.



Fig. 12. Koźuchów, Krośnińska Gate, general view from the west (photo by A.Legendziewicz)

The breastwork was laid to a regular single-stretcher bond pattern, with carefully made, horizontal, flat joints that were undercut at the bottom, and vertical flat joints with a groove.

The foregate was modernized simultaneously with the construction of the outer circuit in the third quarter of the 15th century. Slot openings were arranged in the crenellation gaps within the breastwork. Their inner reveals were shaped as splay embrasures and topped with half-brick-thick staple arches. The foregate was built in ceramic blocks, 7–8 cm/11–12.5 cm/26–27 cm in size, arranged in a regular single-stretcher bond pattern with a flatly smoothed joint.

Foregate conversions in the Renaissance style probably took place in the thirties or forties of the 16th century⁶. A four-storey building with an entrance in the north was separated with a wall parallel to the gateway within a semi-circular section. It was covered with a V roof, which was limited along the curtain line with an attic consisting of repeated, dovetail (two-quadrant) segments on 40/160-centimetre plinths. The parapet segments were arranged on the top floor along the axes of the mostly rectangular and keyhole gunports, of which one survived.

The entrance to Koźuchów from the east was protected by Głogowska Gate, whose framing consists of a tower erected on a rectangle-like plan with outer dimensions of about 9.5/9.75 meters. Probably due to boggy ground, its outline was located within the circuit. The

⁶ The first parapet with a similar comb layout was completed in 1529 during the encastellation of Saint John's Parish Church in Paczków [65, pp. 171–174].

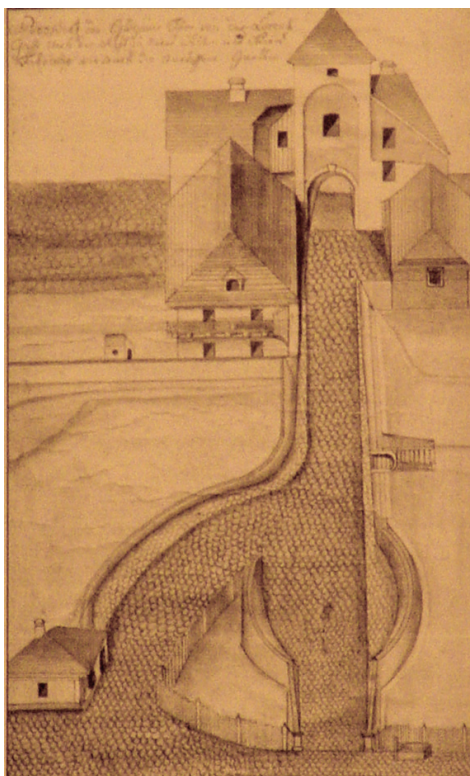

Fig. 13. Kozuchów, Glogowska Gate from the 2nd half of the 18th-century view from the moat (illustration from the collection of the Regional Chamber in Kozuchów)

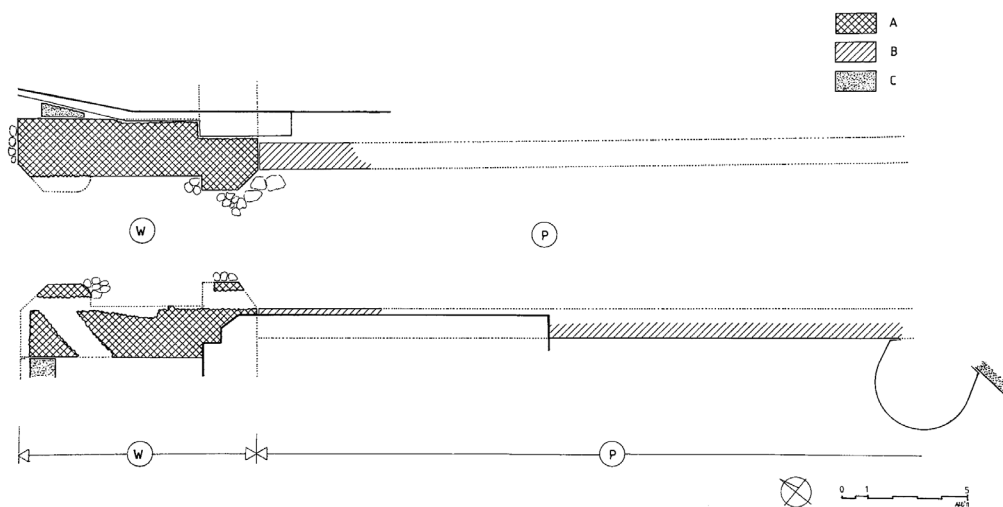

Fig. 14. Kozuchów, Glogowska Gate, projection of fundaments with chronological wall stratification. A – 1st half of 14th century; B – 2nd half of 14th/1st half of 15th century; C – 18th century; W – tower, P – foregate; reconstruction lines – dotted (drawn by A. Legendziewicz)

gateway was located in the basement, as was the case with Krośnieńska Gate. The edges of its openings with chamfered corners were framed with carefully pressed blocks of bog iron ore. Analysis of archival iconography indicates that on the eastern façade there was a lancet recess for a portcullis whose runners had probably been at a distance not greater than 1 meter from the gateway edge. The city was probably also secured with a drawbridge and a double gate. The opening from the side of the city was also framed with chamfered edges. Bog iron ore blocks were also used to build the chamfered base and the facade, which was probably plastered. Analysis of a Koźuchów panorama dated 1537 indicated that the tower finial consisted of crenellation and was covered with a short-ridged hip roof [62].

The tower's foundation walls were built in boarded trenches, in erratic boulder filled with smaller stones. The basement walls are preserved to a height of about 20–30 centimeters above the historic cobblestone level. The wall face was made of precisely pressed blocks of bog iron ore, with the wall having been filled with cobblestones and lime mortar.

Głogowska Gate was probably extended at the same time as Krośnieńska Gate. Its rectangular foregate, about 8.4 meters in width and about 25 meters in length, was erected along the axis of the gateway opening from the moat side. It was abutted onto the frontal façade of the tower. The eastern neck closure probably consisted of a drawbridge. The gateway was about 6 meters wide and the walls were almost 1.2 meters thick. The side walls were built in erratic boulder, which was laid in layers interleaved with smaller stones and pieces of bricks.

Analysis of the existing Głogowska Gate iconography showed that the gate architecture was probably converted in the 18th century and given Baroque forms. The tower was surrounded by two single-storey, four-axis tenement buildings. The gate consisted of two storeys and the gateway opening was trimmed with keyed framing. The façade was framed and crowned with protruding molding. The building was covered with a tent roof, a spire with a gold-plated knob, a spire element and a seven-point star. The gate object was probably demolished in the first half of the 19th century, before 1819 [4, p. 49; 45, p. 71].

6. Namysłów – Krakowska and Wrocławska Gates

The chartered city of Namysłów was on a plateau headland restricted by the Widawa river, on an elongated quadrilateral plan whose longer sides converge in a westerly direction. The medieval fortifications were strengthened with three gates: Krakowska (Kluczborska) in the east, Wrocławska (Brzeska) in the south-west and Wodna in the north, all of which were built in the 14th century. They consisted of two (circles) circuits: an inner one, *i.e.* curtains and 37 towers built between 1348 and at least 1418; and an outer one, which was intended for the usage of firearms and was built from 1462 up to the beginning of the 16th century [36]. The fortifications were modernized in the 17th century, while the erection of a fortified tower jacket started in 1653 [17, pp. 164–165]. The levelling of the jacket started in 1764; the medieval walls, certain fortified towers and Wrocławska and Wodna gates were demolished in the 19th century [17, p. 174, 204; 23, pp. 44–46].

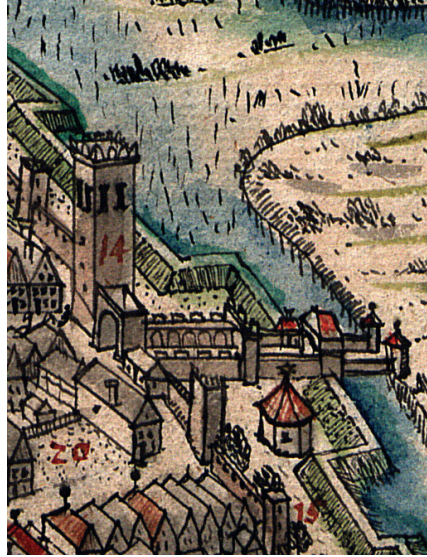

Fig. 15. Namysłów, Krakowska Gate complex from the middle of 18th century – a fragment of the F.B. Werner (drawing from the collections of the University Library in Wrocław)

An older city chronicle written by Jan Froben between 1495 and 1503 contains notes on the construction of the wall [16]⁷. The entries contained therein lead to the proposition that the inner circle was built in stages, starting from the east stretch, which was completed before 1348 [16, line 1], then the south stretch that ended in Wrocławska Gate was rebuilt in 1396, and finally the north stretch and Wodna Gate were completed after 1415 [16, line 14]. The modernization of the east stretch was completed at the end of the 14th century, when Piekarska tower was built in 1394; two years later, in 1398, the tower, Krakowska Gate, and the Kaczmarska tower were also built [16, line 10].

The subject of medieval fortifications was first raised by H. Lutsch, who mentioned wall relicts and the year 1350 as the time when the construction of the wall started [49, p. 499]. This topic has been presented more extensively by Kurt Degen [11, pp. 123–126]. Based on the Froben chronicle, he came to the conclusion that the city was secured with walls in 1350 and that the two gates, Krakowska (Kluczborska) and Wrocławska (Brzeska), existed in 1371. More features were added later: Wodna Gate with a tower in 1388, watchtowers along the walls and near certain gate towers in 1390, Piekarska tower behind the parish church in 1394, Wrocławska Gate with a tower in 1396, and Karczmarska tower by Krakowska Gate and Oborowa tower in front of the castle in 1398. The construction of the inner circuit was finished in 1415 when a stretch west of the Wodna Gate was completed. The topic of the construction of the city fortifications was more thoroughly examined by Kurt Bimler [7, pp. 78–90]. Based on the Froben chronicle and street maps, he found that the construction of the walls in the

⁷ The Koschny chronicle is considered missing, and that by reverend W. Libich duplicates Froben chronicle entries.

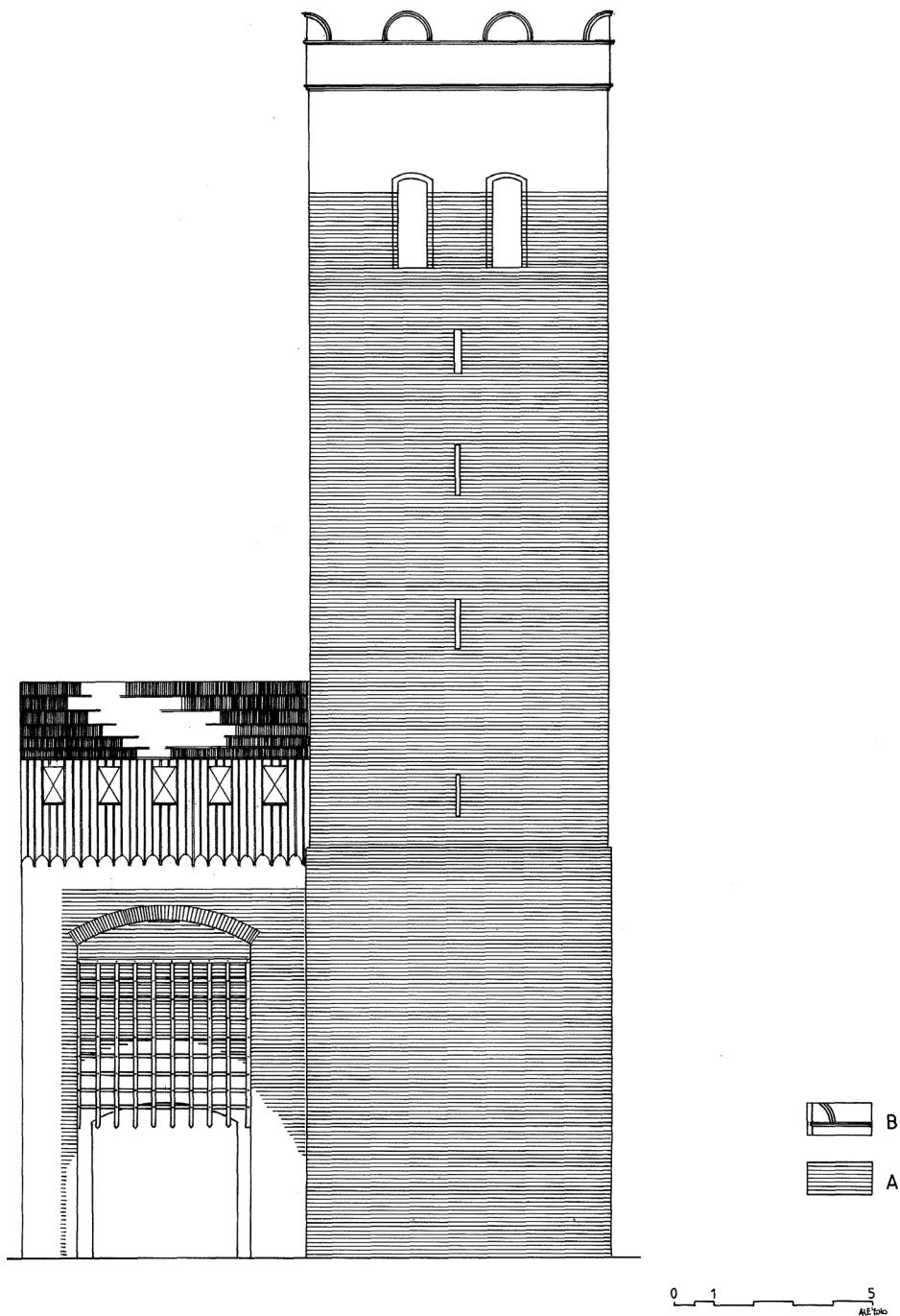

Fig. 16. Namysłów, Krakowska Gate complex, eastern elevation with chronological wall stratification and reconstruction of the attic from around the middle of the 16th century.
 A – from around 1396, B – reconstruction lines (drawn by A. Legendziewicz)



Fig. 17. Namysłów, Krakowska Gate complex – view from the west (photo by A. Legendziewicz)

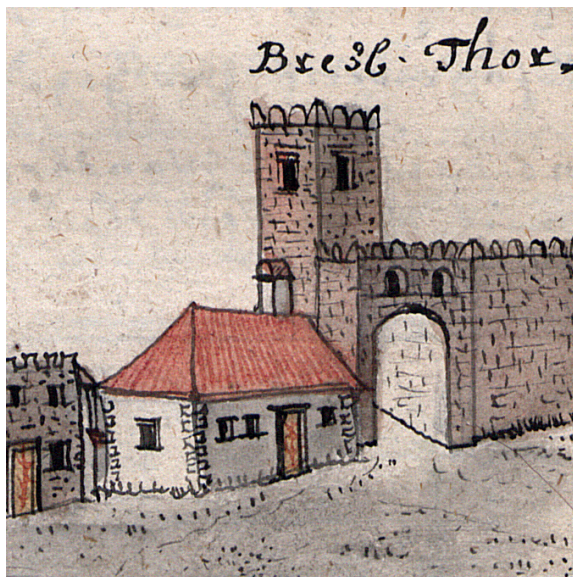

Fig. 18. Namysłów, the Wrocław Gate complex from the middle of 18th century – a fragment of F.B. Werner (drawing from the collections of the University Library in Wrocław)

east and of Krakowska Gate started in 1350, and then the work continued in the north and south towards the west. Wodna Gate with a tower was erected in 1388, and Piekarska tower was erected in the north-eastern corner of the circuit in 1394. Karczmarzka tower, also called Wysoka, was built in the south-eastern corner in 1398. A new Wroclawska Gate was built in 1390. The opinions of K. Degen and K. Bimler were compiled by T. Chrzanowski and M. Koniecki [23, pp. 44–46]. A concise description of the construction and the indication that the circuit was built between 1350 and 1359 was published by J. Pilch [58, pp. 118–119].

The latest research into medieval walls carried out by Cz. Lasota and A. Legendziewicz shows a slightly different view [36]. By referring to the Froben chronicle note dated 1348, the authors confirmed that Namysłów was protected with masonry fortifications and Krakowska Gate in the east; however, there were no walls in the north, south and by certain fortified towers [36, pp. 6–9]. The analysis of further city chronicle entries and the notes on the wall subsidies given by Charles IV, the Holy Roman Emperor, prove that priority was given to the fortified circuit of this strategically located city [36, p. 6]. After the curtain had been built west of Wodna Gate, its east stretch was modernized: certain fortified towers were made higher in 1390, and two high towers, Piekarską in the north-eastern corner and Karczmarzka in the south-eastern corner, were erected in 1394 and 1398 [36, pp. 7, 8]. These works were accompanied by the construction of a new Krakowska Gate and a tower in around 1396 [36, pp. 7, 8]. Research on architectural and restoration issues relating to this gate was published by the author of this article [40, pp.106–108]. Architectural research on the preserved relicts of the Wroclawska Gate was carried out in 2012 [44].

Krakowska Gate tower was built on a 7.6/7.8-meter, square-like plan and it was as high as 26 meters above the present ground level. Its interior was divided with beamed ceilings into at least seven storeys. The lowest floor was designed as a dungeon. It had a staple vault and a circular hole to throw prisoners in. Higher floors marked out by offsets were accessible by ladder. The entrance to the inside was situated on the western façade at a height of about 9.8 meters above the present ground level and topped with a semi-circular arch. Each of the storeys was lit through slot openings in embrasures which were capped with half-brick-thick staple arches. At level +9.85, there is one opening in the east wall, at level +13.80 there are three of them in the north, east and south, whereas at higher levels there are four of them. Engraved inscriptions and drawings were found on the side walls of embrasures, with the oldest one dating back to 1418. Two holes of uneven heights of up to 1.80 meters and a width of about 1 meter survived in each of the walls on the top preserved storey (at +24.80 m). Their outer edges were formed to create deep, half-brick-wide jambs – relicts of wooden flap closures. Smooth façades were erected to a regular, single-stretcher bond pattern in two colors, with randomly arranged, glazed heads with a blueish tone. Remnants of red paint were found on clean joints on the wall face, which may prove that the façade was painted soon after erection.

A curtain with a gateway was added to the south-western corner at the same time as the tower was built. The rectangular opening was topped with a staple arch and closed with a double gate and a portcullis installed in a recess. A wooden porch with a hoarding was probably built over the gateway.

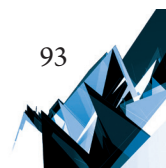

Wroclawska Gate, whose relicts are under the roadway in B. Chrobrego street, was built as one of the first elements of the city fortifications. The Froben chronicle confirms that it was probably erected after 1350 [16, line 1; 36] and subjected to conversion in 1396 [16, line 10]. The first gate consisted of a tower and an about 7-metre-long stretch of curtain, which adhered to the tower in the west. The tower, whose height is now unknown and whose outer outline sides were about 7.5 meters long, was built on a continuous foundation ranging from 1.5 to 1.7 meters in width. It was built in erratic boulder and interleaved with fragments of bricks. The curtain foundation running in a westerly direction and ranging between about 2 and 2.5 meters in width was built with the adoption of a similar technology. A gate opening of unknown shape was at a distance of about 2.5 meters from the tower façade. Based on the relicts recorded, its width can be estimated at about 2.5 meters.

In the light of the Froben chronicle, the object was rebuilt by master *Eintz* in 1396 [16, line 10]. The excavations confirmed that the relicts of the gate neck that adhere to the south-western corner of the tower might be part of this rebuilt gate. The findings consisted of two

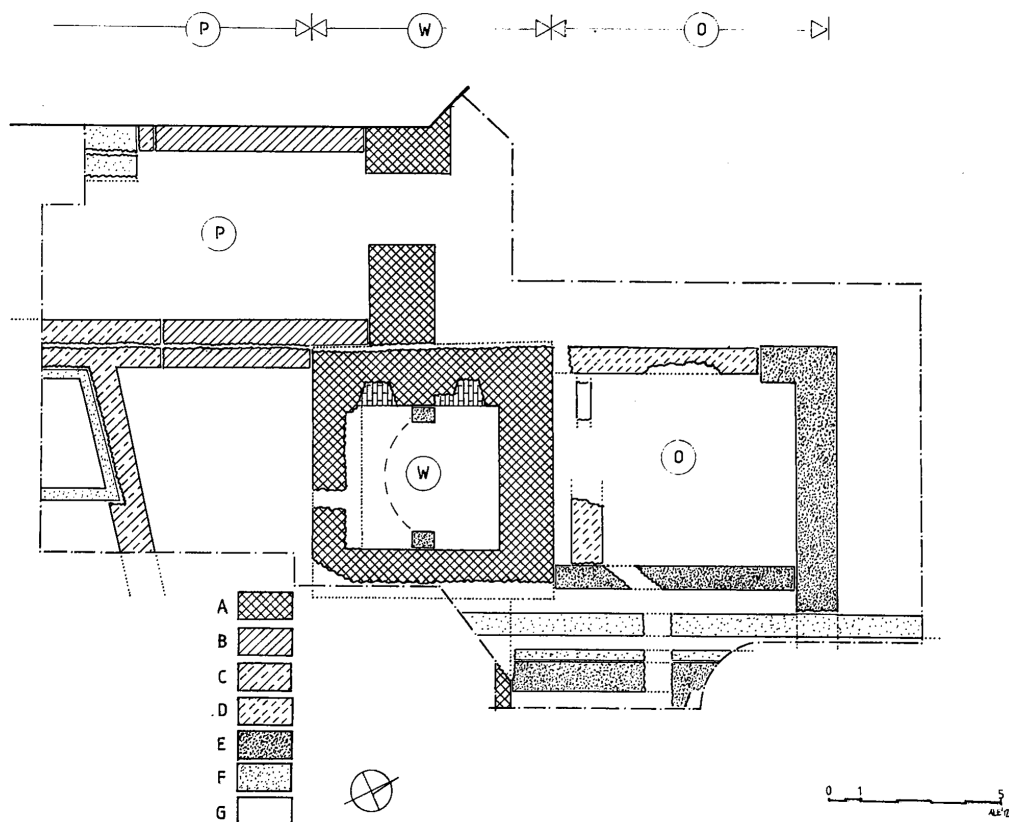

Fig. 19. Namysłów, the Wroclawska Gate Complex, projection of foundations with chronological wall stratification. A – 2nd half of the 14th century; B – around 1396; C – end of the 15th century; D – 16th century; E – 18 century; F – 19th century; G-unrecognized walls; W – tower, P – foregate; O – guardhouse (Renaissance); reconstruction lines – dotted (drawn by A. Legendziewicz)

parallel continuous foundations that were over 8 meters in length and about 6 meters apart. The south closure of the gateway remains unknown; it was rebuilt in the second half of the 15th century, together with the construction of an outer circuit. The approx. 1.50-meter-wide foundations were built in erratic boulder and interleaved with pieces of bricks.

It is likely that a print by F. B. Werner that dates back to the middle of the 18th century shows the architecture of the gate after these conversions. The tower was probably made higher to the level of two storeys above the curtain crown and the foregate. In the upper part there was a rectangular firing port in each of the south, north and west walls, and two such ports in the east wall. The form of a tower finial remains unknown as it was replaced with an attic in the Renaissance.

The construction of an outer fortification belt intended for use with firearms near Wrocławska Gate was mentioned in a note from 1499 that concerned a fortified tower at the rear of nearby Saint George's Church and the Church of the Holy Spirit [16, line 139]. It can be assumed that the modernization of the circuit in that part of the city was complete at the turn of the 15th and 16th centuries. An outer wall was erected obliquely to the south wall of the gate tower at a distance of about 5 to 6 meters from the tower. The south closure of the gate neck was converted while the outer wall was being built. The walls were partly demolished, and only about 6.2–6.5-metre-long stretches remained. The approx. 1-metre-wide continuous footings were built of 7.5–9cm/12–13cm/25–26cm bricks of different colors ranging from orange to black due to baking.

Changes in the architecture of the object came with the Renaissance. A guard building was built near the north wall of the tower on a rectangular plan, of which the remains of the footings of two walls survived. A south wall foundation of about 1.5 meters in length was found at a distance of about 50cm from the north façade of the tower, whereas the west wall foundation, which is about 4.8 meters in length, was built in parallel to the gateway axis. The tower and foregate finials were also rebuilt at that time. They received an attic consisting of semi-circular elements, and of quadrant elements in the corners.

7. Prudnik – Dolna (Karniowska) Gate

There were three gates in the medieval circuit of the city walls in Prudnik: Górna (Nyska) Gate pointing at Nysa and Głucholazy, Dolna (Karniowska) Gate pointing at Biała, Głogówek and Krnov and Nowa (Kapucyńska) Gate, which was built in 1556 [68, p. 200]. Analysis of archival iconography indicates that the transformations in the architecture of the towers that secured entrances to the towns took place in the second half of the 16th century. The process of demolition of the circuit started in the first half of the 19th century – Górna Gate was demolished in 1843 and Nowa Gate was demolished four years later [68, p. 200]. The following elements of the first circuit survived: Baszta Więzienna [the prison tower] and a stretch of the curtain, both of which are now parts of Museum Ziemi Prudnickiej, and Dolna Gate tower, which is partly blended in with the tenement buildings on the south frontage of S. Batory street.

The two lowest storeys of the gate tower were built on a 7.8/8.1-metre square-like plan. From a height of 15 meters above ground level the tower is octagonal in view. It is topped with a masonry pyramid cupola surrounded by a low crenellation-type attic.

The first note on the fortified circuit dates back to 1327 and comes from the mention of a journey by Duke Bolesław III the Wasteful via Prudnik and Głubczyce to Racibórz [68, p. 27]. Dolna Gate is mentioned in a deed dated 31 July 1481 as the boundary of the municipal properties governed by Governor George of Wrбно [68, s. 49]. A document dated 1 July 1556 contains a note on the assignment of a square in the suburb, in front of the Dolna Gate, to the city by Isabella Jagiellon, Queen consort of Hungary on behalf of her son, John Sigismund, for the construction of an inn for travelers [68, pp. 63–64].

The aforementioned notes formed the grounds for the consistent image of the transformations in the tower's architecture in the current literature. H. Lutsch supported the opinion on the medieval origin of the tower and linked its Renaissance form to the 1580 conversions that are proved by an element on the spire [51, p. 11, table 186/5]. A similar view of the development of the tower architecture was presented by Ernst Königer [30, p. 59, il.12]. The findings were confirmed by T. Chrzanowski and M. Koniecki, who supported the view that the Gothic tower was built in the 15th century and transformed at the end of the 16th century [25, p. 58, il.63]. The above findings were also quoted by J. Pilch [58, p. 168]. The relevant architectural research was carried out while preservation work was undertaken in 2006 [37]. The results were used to verify the propositions published so far and to discuss the façade restoration issues [40, pp. 105–117].

The oldest parts of Dolna Gate were probably built in the second half of the 14th century, as is proved by the construction material applied – crushed stone laid in layers – and the building

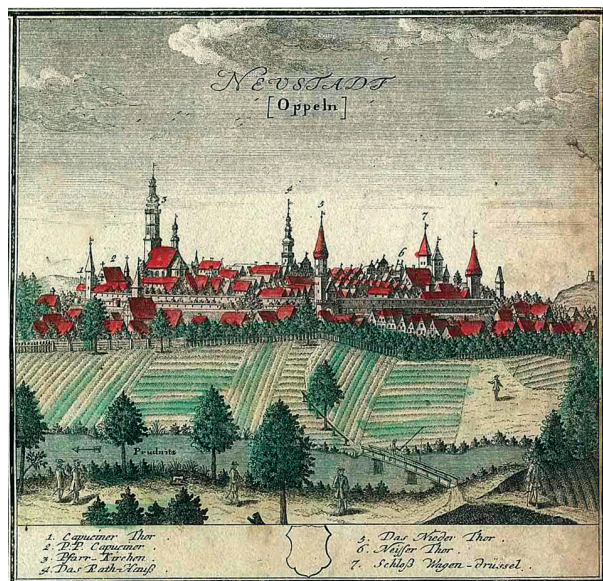

Fig. 20. Prudnik, panorama of the city from the east from around 1738 by F.B. Werner – Dolna Gate – No. 5 (drawing from the collections of the University Library in Wrocław)

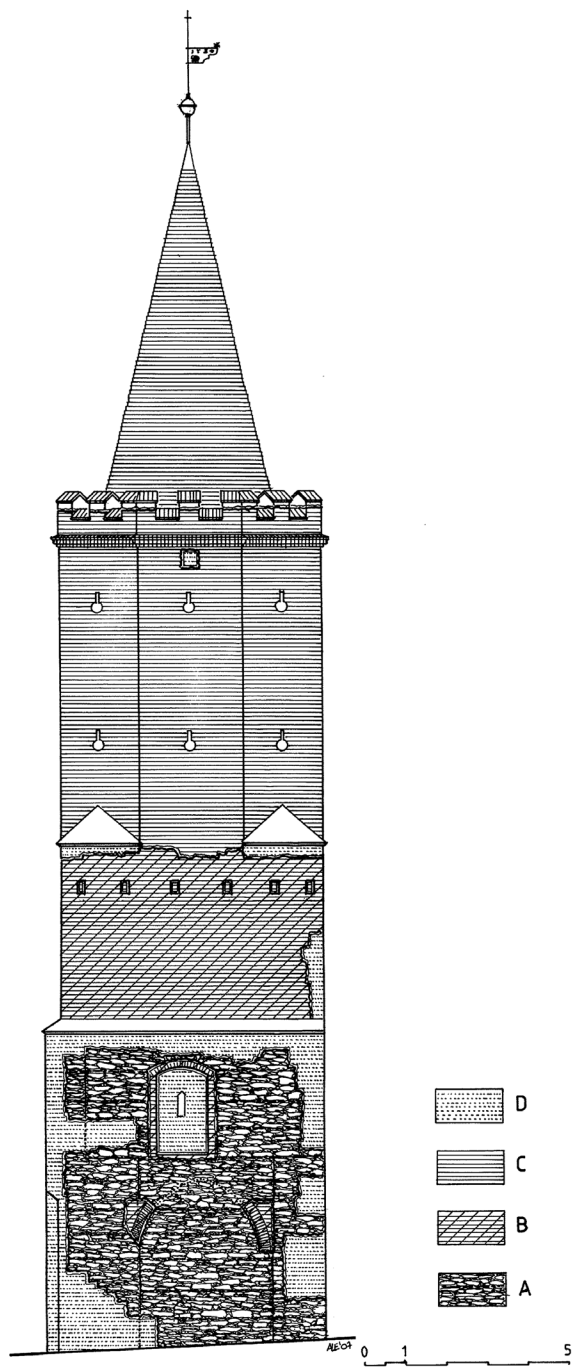

Fig. 21. Prudnik, Dolna Gate's tower, north elevation with chronological wall stratification. A – 1st half of 14th century; B – 2nd half of 15th century; C – around 1580; D – 19th and 20th centuries (drawn by A. Legendziewicz)



Fig. 22. Prudnik, Dolna Gate's tower – view from the east (photo by A. Legendziewicz)

method. The architectural layout of the gate object consisted of a square, a plastered tower, and a gateway adjoining the tower on the north side. Its height could have been about 10 meters and it was higher than the adjoining gateway. The original finial remains unknown, but it was probably crenellation. The tower was accessible through an entrance in the north at the first-floor level. In the basement, where the walls were up to two meters thick, there was a prison dungeon that was originally covered with a ceiling. The gateway ran into the north of the tower. Its outer wall was up to two meters thick and the inner walls were a little over one meter thick. A parapet walk was situated at a level of about 6 meters above the present ground, with an almost 2-metre-high breastwork with probably crenellation merlons of unknown spacing.

The tower and the gateway were rebuilt probably in the second half of the 15th century; the gates might have been preceded by a foregate in a rectangle shape, as was seen in a street map from 1750. The stone finial of the tower was demolished and a brick structure that was about 5 meters high was built on top to a single-stretcher bond pattern. A hoarding was built around the tower wall crown in the east, north and probably south, at a height of over 11 meters above the present cobblestone level. Its construction was based on wooden brackets fixed in the wall at 80–110 cm intervals; a row of wall pockets just beneath the octagonal part survived to the present times. A new finial was probably shaped in the form of a hip roof. The stone and brick parts of the façade were probably integrated by the application of thin mortar,

which is evident in how the brick wall joint was formed. The entrance framing in the north was also transformed, as the entrance opening was enlarged and enclosed with brick jambs and topped with a staple arch. Inside the tower, above the dungeon, there was a brick barrel vault with a hole to throw prisoners in.

The gateway was rebuilt and took the form of a gatehouse with a roof whose ridge ran in parallel to the curtain line. A cross vault, with retainers carved in the stone wall of the tower in the south, was built in the basement above the gateway. Above, there was a fortified storey accessible through a door opening in the tower.

The renaissance transformations that took place probably in 1580 involved the demolition a Gothic finial and the construction of a two-storey, about 7-metre-high octagonal structure on top of the tower. The walls were crowned with a low crenellation-type attic, with a high pyramid copula and a sandstone spire with a mast and a knob and a decorative spire element showing the date of the rebuild.

8. Summary

The conservation projects implemented over recent years made it possible to undertake research into medieval gates in several of Silesia's cities. The results formed the grounds for the verification of the propositions published to date in literature and at the same time they revealed the complexity of the construction and evolution of the city gate objects. The examples presented above indicate that decisions on the construction of fortified walls were taken by municipal authorities relatively quickly after city charters had been granted and these cities had become established. Originally, the cities were presumably surrounded with wooden and earthen embankments, which from the end of the 13th century were replaced with masonry circuits. When they were erected, particular emphasis was placed on the form and military functions of the city entrances. The gate openings were strengthened by being located in the tower's basements (*e.g.* Głogowska Gate in Koźuchów) or close to the towers (*e.g.* Dolna Gate in Prudnik). The gateways were secured with doors and portcullises, with the latter being installed in specifically shaped recesses and equipped with runners (*e.g.* Lewińska Gate in Grodków). The towers were higher than the adhering curtains and probably crowned with crenellation and wooden hoardings (*e.g.* the Górna Gate tower in Głucholazy).

The first stage of modernization in the second half of the 14th century and at the beginning of the following century probably consisted in the introduction of foregates. These foregates were usually built on a rectangle plan (*e.g.* Grobnicka Gate in Głubczyce), whose length was as much as 25 meters (*e.g.* Głogowska Gate in Koźuchów). Krośnieńska Gate in Koźuchów was an exception as its foregate was built on an elongated horseshoe plan. It cannot be confirmed unambiguously whether or not the tower was made higher and crowned with hoardings while the neck was being constructed (as was the case with Dolna Gate in Prudnik). The recognized transformations could have been related to the reconstruction after the Hussite wars. The modernization of the gate objects could have involved the erection of new objects, as was the case with Krakowska Gate in Namysłów

Modern transformations to city gate architecture mostly consisted in giving cities a Renaissance look, *inter alia* by the addition of finials in the form of ornamental parapets in the place of a military hoardings. This is one indication that the military significance of the medieval circuits of city walls was slowly disappearing. However, it was also a symbol of the inhabitants' wealth and emphasized a representative form of city entrance.

References

- [1] Archiwum Państwowe w Opolu (akta miasta Głucholaz, akta miasta Grodkowa).
- [2] Andrzejewski T., Szukielowicz Z., *Koźuchów – średniowieczne fortyfikacje*, Nowa Sól 2001.
- [3] Andrzejewski T., Szukielowicz Z., *Mury obronne Koźuchowa w świetle nowych ustaleń*, [in:] *Budownictwo obronne Środkowego Nadodrza. Powiat nowosolski*, [ed.] T. Andrzejewski, Nowa Sól 2003, pp. 66–77.
- [4] Andrzejewski T., Szukielowicz Z., *Mury obronne Koźuchowa*, Koźuchów 2009.
- [5] Bednara E., *Aus der Frühgeschichte der deutsche Stadt Leobschütz, Beiträge zur Heimatkunde Oberschlesiens*, 1931.
- [6] Biermann G., *Geschichte der Herzogtümer Troppau und Jägerdorf*, Vol. 1, Teschen 1874.
- [7] Bimler K., *Die schlesischen massiven Wehrbauten*, Bd. 1, Breslau 1940, pp. 78–90.
- [8] *Codex diplomaticus Silesiae (CDS)*, Vol. 7, ed. C. Grünhagen, *Regesten zur schlesischen Geschichte*, part 2, Breslau 1875.
- [9] Chorowska M., *Średniowieczna kamienica mieszczańska we Wrocławiu*, Wrocław 1994.
- [10] *Chronik der Stadt Grottkau*, von Heide, Grottkau 1867; *Deutsches Städtebuch*, von E.I. Keyser, Stuttgart–Berlin 1939.
- [11] Degen K., Bleyel W., Werbick W., Focke F., *Die Bau und Kunstdenkmäler des Kreises Namslau*, Breslau 1939.
- [12] Dziewulski W., *Głubczyce. Studium historyczno-urbanistyczne miasta*, maszynopis w archiwum Wojewódzkiego Konserwatora Zabytków w Opolu, PKZ, Wrocław 1956.
- [13] Eckert W., *Rewitalizacja starego miasta w Koźuchowie – system fortyfikacyjny ponownie do wykorzystania*, [in:] *Renowacja budynków i modernizacja obszarów zabudowanych*, Vol. 4, ed. T. Biliński, Zielona Góra 2008, pp. 109–118.
- [14] Eysymontt J., *Studium historyczno-architektoniczne murów miejskich w Głubczycach*, maszynopis w archiwum WKZ w Opolu, PKZ, Wrocław 1974.
- [15] Förster G., *Analecta Freystadiensia oder Freystädtische Chronika theils aus denen in vielen jahren gesammelten Miscellaneis Herrn M. Johann Gottfried Arts ...*, Lissa 1751.
- [16] Froben J., *Annales Ioannis Frobenii ab anno 1347*, Archiwum Państwowe we Wrocławiu, Rep. 135, E 99a, sygn. 679.
- [17] Goliński M., Kościk E., Kęsik J., *Namysłów. Z dziejów miasta i okolic*, Namysłów 2006.
- [18] Hofrichter R., *Geschlichliche Einzelbilder der Stadt Leobschütz*, [in:] *Heimatkunde des Kreises Leobschütz*, part 2, Vol. 2, Leobschütz 1911.
- [19] *Die Inventare der nichtstaatlichen Archive Schlesiens I. Kreis Grünberg und Freystadt, Codex Diplomaticus Silesiae*, Bd. XXIV, hrsg. K. Wutke, Breslau 1908.

- [20] Jurek T., *Trzynastowieczne lokacje miejskie w dobrach Pogorzeliów*, [in:] *Civitas & Villa. Miasto i wieś w średniowiecznej Europie Środkowej*, Wrocław–Praha 2002, pp. 89–93.
- [21] *Katalog Zabytków Sztuki w Polsce, województwo opolskie, powiat Głubczycki*, Vol. VII, Issue 2, ed. T. Chrzanowski, M. Koniecki, Warszawa 1961.
- [22] *Katalog Zabytków Sztuki w Polsce, woj. opolskie, pow. Grodkowski*, Vol. VII, Issue 3, ed. T. Chrzanowski, M. Koniecki, Warszawa 1964.
- [23] *Katalog zabytków sztuki w Polsce, woj. opolskie, pow. Namysłowski*, Vol. VII, Issue 7, ed. T. Chrzanowski, M. Koniecki, Warszawa 1965.
- [24] *Katalog Zabytków Sztuki w Polsce, woj. opolskie, powiat Nyski*, Vol. VII, Issue 9, ed. T. Chrzanowski, M. Koniecki, Warszawa 1963.
- [25] *Katalog Zabytków Sztuki w Polsce – woj. opolskie, pow. Prudnicki*, Vol. VII, Issue 12, ed. T. Chrzanowski, M. Koniecki, Warszawa 1960.
- [26] Kowalski S., Muszyński J., *Koźuchów*, Poznań 1959.
- [27] Kowalski S., Muszyński J., *Koźuchów*, [in:] *Studia nad początkami i rozplanowaniem miast nad Środkową Odrą i Dolną Wartą*, Vol. 2. Zielona Góra 1967, pp. 235–248.
- [28] Kowalski S., Muszyński J., *Koźuchów. Zarys historii*, Koźuchów 1995.
- [29] *Koźuchów. Zarys dziejów*, ed. T. Andrzejewski, Koźuchów 2003.
- [30] Königer E., *Kunst in Oberschlesien*, Breslau, 1938.
- [31] Kutzer P., *Aus einer kleinen Fürstenstadt, Historischer Rückblick auf die Vergangenheit von Ziegenhals*, Ziegenhals 1928.
- [32] Kutzer P., *Kirchengeschichte von Ziegenhals*, Ziegenhals 1932
- [33] Kutzner M., *Studium historyczno-urbanistyczne miasta Grodkowa*, maszynopis w archiwum WKZ w Opolu, PKZ Wrocław, 1962.
- [34] Lasota C., Legendziewicz A., *Wyniki badań architektonicznych i wnioski konserwatorskie do remontu ratusza w Grodkowie pl. Rynek 1 i jego otoczenia (mury i wieże obronne)*, maszynopis w archiwum Wojewódzkiego WKZ w Opolu, Wrocław 2005.
- [35] Lasota C., Legendziewicz A., *Badania gotyckiej architektury Namysłowa. Kościół parafialny miasta lokacyjnego*, Architectus Vol. 1–2 (17–18)/2005, Wrocław, pp. 21–33.
- [36] Lasota C., Legendziewicz A., *Badania gotyckiej architektury Namysłowa. Fortyfikacje miejskie*, maszynopis w bibliotece Instytutu Historii Architektury Sztuki i Techniki Politechniki Wrocławskiej, Wrocław 2006.
- [37] Legendziewicz A., *Wieża Bramy Dolnej w Prudniku. Wyniki badań architektonicznych oraz wnioski konserwatorskie*, maszynopis w archiwum WKZ w Opolu, Wrocław 2006.
- [38] Legendziewicz A., *Wieża Bramy Dolnej w Prudniku w świetle w światła najnowszych badań*, [in:] *Ziemia Prudnicka* 2007, s. 182–187.
- [39] Legendziewicz A., *Wieża Bramy Górnej w Głucholazach (pow. Nysa). Wyniki badań architektonicznych oraz wnioski konserwatorskie*, maszynopis w WKZ w Opolu, Wrocław 2008.
- [40] Legendziewicz A., *Problematyka badawczo-konserwatorska wybranych zespołów bramnych na Śląsku*, [in:] *Obwarowania miast – problematyka ochrony, konserwacji, adaptacji i ekspozycji*, [ed.] A. Górski, Materiały Międzynarodowej Konferencji Naukowej, Koźuchów 2010, s. 105–117.



- [41] Legendziewicz A., *Rewaloryzacja wybranych obiektów zabytkowych – element podnoszący atrakcyjność turystyczną gminy Głuchołazy*, [in:] *Transgraniczny potencjał turystyczny Gór Opawskich*, Materiały Konferencji Naukowej, Głuchołazy 2011, pp. 76–96.
- [42] Legendziewicz A., *Mury Miejskie w Kozuchowie. Wyniki badań architektonicznych oraz wnioski konserwatorskie*, maszynopis w archiwum Inwestora, Wrocław 2011.
- [43] Legendziewicz A., *Brama Grobnicka w Głubczycach. Wyniki badań architektonicznych oraz wnioski konserwatorski*, maszynopis w archiwum WKZ w Opolu, Wrocław 2012.
- [44] Legendziewicz A., *Wyniki badań architektonicznych relikwów bramy Wrocławskiej w Namysłowie*, mps w archiwum WKZ w Opolu, Wrocław 2012.
- [45] Legendziewicz A., *Średniowieczne fortyfikacje Kozuchowa*, [in:] *Lubuskie Materiały Konserwatorskie*, ed. B. Bielinis-Kopeć, tom 9, Zielona Góra 2012, pp. 63–72.
- [46] Legendziewicz A., *Badania architektury Grodkowa. Średniowieczne fortyfikacje miejskie*, [in:] *Z dziejów Grodkowa i ziemi grodkowskiej, cz 2*, ed. A. Dawid, Dom Współpracy Polsko-Niemieckiej, Grodków 2015, pp. 67–88.
- [47] Legendziewicz A., *Od średniowiecznej warowni do barokowego klasztoru. Historia powstania i przekształceń zamku w Kozuchowie*, [in:] *Lubuskie Materiały Konserwatorskie*, Vol. 12, Zielona Góra 2015, pp. 23–37.
- [48] Loose K., *Mury obronne Kozuchowa*, maszynopis w archiwum WKZ w Zielonej Górze, 1962.
- [49] Lutsch H., *Verzeichnis der Kunstdenmäler der Provinz Schlesien*, Bd. II, *Die Landkreise des Reg. – Bezirks Breslau*, Breslau 1889.
- [50] Lutsch H., *Verzeichnis der Kunstdenmäler der Provinz Schlesien*, Bd IV, *Die Kunstdenkmäler des Reg.-Bezirks Oppeln*, Vol. 4 Breslau 1894.
- [51] Lutsch H., *Bilderwerk Schlesischer Kunstdenkmäler*, Breslau 1903.
- [52] Maler K., *Głubczycki mur obronny*, [in:] *Kalendarz Głubczycki*, 2001, pp. 159–167.
- [53] Maler K., *Dzieje Głubczyc do 1742 roku*, Opole 2003.
- [54] Maler K., *Dzieje Głubczyc w latach 1742–1945*, Głubczyce bd.
- [55] Minsberg F., *Geschichte der Stadt Leobschütz*, Neisse 1882.
- [56] Piechaczek B., *Bramy miejskie w Głubczycach i ich przedbramia przed 1770 r.*, [in:] *Głos Głubczyc*, 9/2005, s. 19.
- [57] Piechaczek B., *Średniowieczne kamienne obwarowania miast Opolszczyzny do końca XV wieku*, praca doktorska, Katolicki Uniwersytet Lubelski Jana Pawła II, Lublin 2006.
- [58] Pilch J., *Leksykon zabytków architektury Górnego Śląska*, Warszawa 2006.
- [59] Prix D., Wilhoda M., *Hlubčice jako mocenský nástroj Přemyslovské dynastie*, [in:] *Allir unser getrawen Burger*, Časopis Slezského Zemského Muzea, 50/2001, pp. 193–203.
- [60] Przyłęcki M., *Miejskie fortyfikacje średniowieczne na Dolnym Śląsku, Ochrona, konserwacja, ekspozycja 1850–1980*, Warszawa 1987.
- [61] Przyłęcki M., *Budowle zespoły obronne na Śląsku*, Warszawa 1998.
- [62] *Reisealbum Pfalzgraf Ottheinrichs von seinem Zug nach Krakau*, [in:] *Reise, Rast und Augenblick: Mitteleuropäische Stadtansichten aus dem 16. Jahrhundert*, red. Angelika Pabel, Universitätsbibliothek Würzburg, sygn Delin IV, Dettelbach 2002.
- [63] *Schlesisches Urkundenbuch*, Bd. 2, bearb. v. W. Irgang, Wien 1977.

- [64] Stein R., *Das Bürgerhaus in Schlesien*, Tübingen 1966.
- [65] Steinborn B., *Otmuchów, Paczków. Śląsk w zabytkach sztuki*, Ossolineum, Wrocław 1982
- [66] Strzymiński A., *Rys historyczny fortyfikacji Kozuchowa*, [in:] *Fortyfikacje Ziemi Lubuskiej*, Zeszyt sesyjny Vol. 4, Zielona Góra 1998, pp. 9–13.
- [67] Troska F., *Geschichte der Stadt Leobschütz*, Leobschütz 1892.
- [68] Weltzel A., *Historia miasta Prudnika na Górnym Śląsku* (tłum. „*Geschichte der Stadt Neustadt in Oberschlesien*” Neustadt 1870), Prudnik 2005.
- [69] Zlat M., *Attyka renesansowa na Śląsku*, [in:] *Biuletyn Historii Sztuki*, Vol. XVII, 1955.