

PIOTR CYKLIS*

SELECTED ISSUES OF THE MULTISTAGE EVAPORATOR THERMODYNAMICS

WYBRANE ELEMENTY TERMODYNAMIKI WYPARKI WIELOSTOPNIOWEJ

Abstract

The well known multi-stage evaporation is an energy efficient process applied for concentrate juice production. There are however, some important issues concerning its thermodynamics which are not commonly revealed by the producers. The multi-stage design requires a properly designed control system to achieve maximum efficiency and capacity of the evaporator. In this paper, results of the author's practical experience concerning the thermodynamics of the operation of the multi-stage evaporator in the industrial environment are presented. The report describes problems concerning the steady-state evaporator operation, choice of control parameters, and thermodynamics of the transient states.

Keywords: multi-stage evaporation, thermodynamics of the industrial evaporation processes

Streszczenie

Wielostopniowe odparowanie jest powszechnie znanym, energetycznie wydajnym procesem, który jest stosowany przy produkcji koncentratu soku owocowego. Jest jednak szereg problemów dotyczących termodynamiki procesu, które nie są chętnie pokazywane przez wytwórców. Wielostopniowy proces odparowania wymaga zastosowania odpowiedniego sterowania do osiągnięcia maksymalnej sprawności energetycznej i wydajności wyparki. W publikacji pokazane zostały wyniki praktycznego doświadczenia autora dotyczące termodynamiki projektowania i pracy wyparki w zakładzie przetwórczym. Opisane problemy dotyczą pracy wyparki w warunkach ustalonych, doboru parametrów sterowania i termodynamiki stanów niustalonych.

Słowa kluczowe: wyparka wielostopniowa, termodynamika przemysłowych procesów wyparnych

* Prof. Ph.D. D.Sc. Eng. Piotr Cyklis, Faculty of Mechanical Engineering, Cracow University of Technology.

Notation

- \dot{m} – mass flow rate,
 i – specific enthalpy,
 c_w – specific heat,
 t – temperature,
 Q_{stri} – heat loss on the i -th stage,

subscripts

- p – steam,
 k – condensate,
 s – juice,
 i – the parameters and function values at the entrance to the i -th stage, $i+1$ the outlet from the i -th stage.

1. Introduction

The multi-stage evaporation process is widely known [1, 2]. It is applied in sea water desalination, condensed milk production, sugar production, waste drying, paper production etc. [3, 7, 8]. The most important cost of the process is the energy consumption of the evaporator. The first stage of the evaporator is usually powered by fresh steam from steam boiler. The amount of fresh steam from the boiler is dependent upon: the evaporator design; the number of stages (most important factor); the requirements for cleaning periods and ambient conditions. The number of stages for juice concentrate production is limited due to process requirements. There are two design types of multi-stage evaporator – plate heat exchangers, and tube heat exchangers. Plate heat exchangers require less space and are less expensive in production [7, 8]. Tube heat exchangers with falling liquid film are more expensive, but are less affected by the possibility of clogging by particles in juice. Currently, the development of evaporators is concentrated mostly on the control and automation process [3, 5, 9]. The control system, when properly applied, has to implement ambient conditions into the algorithm and consider time delay reactions for each parameter. A properly designed control system results in lower energy consumption and better product quality.

2. Steady state operation of the evaporator

Juice concentrate production has specific temperature requirements. The maximum temperature is limited specific to the fruit type (about 98°C for apple juice, 85°C for so called “soft”, “coloured” fruits). These limits are due to the quality requirement regarding colour and taste. The theoretical low temperature limit of the condenser is the ambient wet thermometer temperature value. The actual produced evaporator capacities in Poland are mostly within 10–30t/h. It is usually the requirement of the user to control the evaporator capacity within 30–100% of the nominal value, because at the beginning and at the end of the season the available amount of fruits is much lower. Fortunately, at the season beginning also the

requirement for fresh steam temperature is lower because of the nature of coloured fruit processing (strawberries, cherries, blackcurrant).

In the multi-stage process, the fresh steam is introduced only in the first stage evaporator, the next stage is powered by the steam evaporated in the previous stage. At each stage, the temperature difference between the inlet juice and inlet steam has to be maintained. Furthermore, at each stage a similar amount of liquid has to evaporate. This amount lowers towards the later stages. The total available temperature difference is the difference between the required first-stage fresh steam temperature and the condensation temperature in the condenser (Fig. 1). The total available temperature difference is distributed according to the energy balance for all stages and the condenser. Since first stages have better heat transfer coefficients due to the juice properties, the temperature differences are lower for first evaporator stages and increase towards the last stages. The minimum acceptable value is 1–2 K on the first stage. During operation, the heat exchanger surfaces are slowly covered with juice deposit. This reduces the heat transfer rate and requires the surfaces to be cleaned. The cleaning is an energy consuming process and therefore negatively influences the energy consumption in the juice processing plant [6].

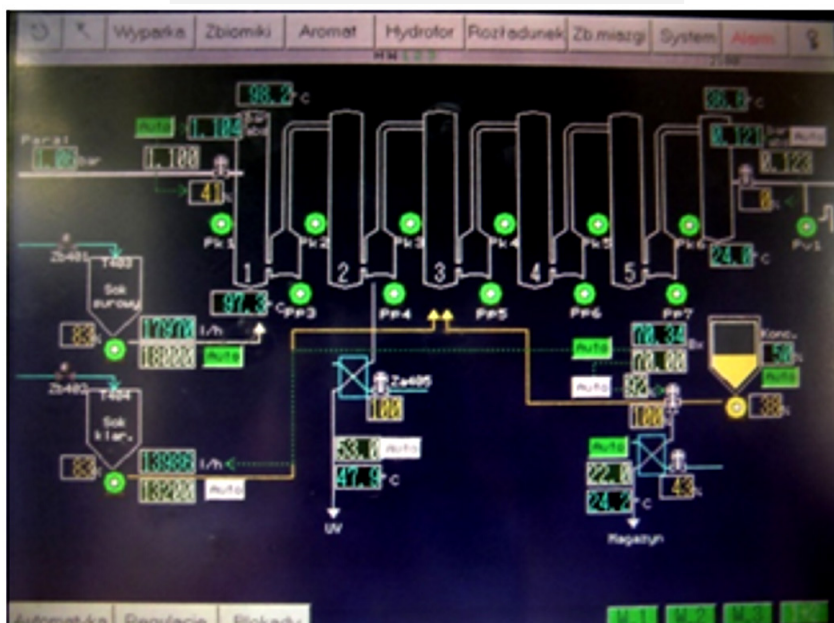

Fig. 1. The screen shot with the schematic diagram of the five stages evaporator in operation

If only energy efficiency of the evaporator during concentrate production is considered, as many stages as possible is the most energy efficient choice. However, in a real plant, six stages in series are the maximum due to operation problems. Considering that the amount of energy required for more frequent cleaning increases with number of stages, five stages are better than six in practical long term exploitation.

The designer of the evaporator has to consider the overall heat transfer coefficients shown in Table 1. Theoretical values differ substantially from ‘industrial experiments’. Measurements undertaken during evaporator operation are both easily obtained and accurate: the amount of evaporated steam is measured on the basis of sugar content [brix] after each stage, and temperatures are measured before and after the stage on both sides of heat exchanger. On this basis, the averaged overall heat transfer coefficient for the whole heat exchanger can be calculated using equations 1 and 2. Results show that this coefficient is also a function of the heat exchanger height [1, 3, 12, 13].

Table 1

The overall heat transfer coefficients according to different sources and industrial experiment

Evaporator stage	k ($\text{W}\cdot\text{m}^{-2}\cdot\text{K}^{-1}$)					
	VDI formula	Chemical resources formula	WIEGAND formula	[www.sugartech.co.za] software	Authors experiment tubes: 6m	Authors experiment tubes: 9m
I	1932	2056	3991	3994	2646	2200
II	1703	1700	3574	2934	2460	2000
III	1580	1471	3050	1950	2175	1300
IV	1284	1364	2401	1225	1709	1000
V	1064	704	1451	601	1215	800

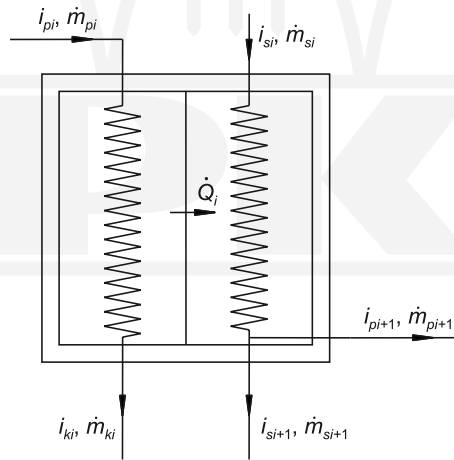

Fig. 2. The schematic drawing of the evaporator stage for energy balance analysis

Figure 2 shows the schematic diagram for the energy balance for the heat exchangers:

$$\dot{m}_{pi}i_{pi} + \dot{m}_{si}i_{si} = \dot{Q}_{str_i} + \dot{m}_{ki}i_{ki} + \dot{m}_{si+1}i_{si+1} + \dot{m}_{pi+1}i_{pi+1} \quad (1)$$

$$\dot{m}_{pi}(i_{pi} - i_{ki}) = A_i \cdot k_i \cdot \Delta t_i = \dot{m}_{pi+1}(i_{pi+1} - c_{wi}t_i) \quad (2)$$

Equations (1) and (2) are used during the design process of the evaporator, for each stage and the condenser.

3. Transient operation states

During every-day operation the system also has to control transient states of evaporator operation. The transient processes occur during start-up, shut-down, load change, juice properties change, and change of the ambient conditions. The issue of non-stationary evaporator process has been considered by [3, 4, 9]. There are two main approaches for transient processes in the evaporator: first one based upon the full mathematical description of the process; the second upon using expert system analysing where a “black box” system is characterised only by its response to excitation [11].

As an example, let's consider Δt_{sri} as the average temperature difference on a heat exchanger. There are several parameters having an influence on its value, of which the most important is the evaporation temperature – t_{si} . The evaporation temperature is a function of the saturation temperature t'' for the pressure p_{si} and boiling point elevation $\Delta t(b, t_i)$ due to the sugar content in the solution.

$$t_{si} = t''(p_{si}) + \Delta t(b, t_i) \quad (3)$$

Differentiating this equation with respect to time τ results in the following equation:

$$\frac{dt_{si}}{d\tau} = \frac{\partial t''}{\partial p_{si}} \cdot \frac{dp_{si}}{p_{si}} + \frac{\partial(\Delta t)}{\partial b} \cdot \frac{db}{d\tau} + \frac{\partial(\Delta t)}{\partial t_{si}} \cdot \frac{dt_i}{d\tau} \quad (4)$$

The functions

$$\frac{\partial t''}{\partial p_{si}} = a_p, \quad \frac{\partial(\Delta t)}{\partial b} = a_b, \quad \frac{\partial(\Delta t)}{\partial t_{si}} = a_t \quad (5)$$

are given for small parameter disturbances and can be calculated from the saturation curve, or derived from the experimental results.

The same mathematical algorithm can be applied for other linear elements of the balance equations, where the ordinary differential equation system is derived after the settlement of the coefficients resulting from partial derivatives.

A practical approach, which in fact is commonly used by the evaporator operators, is the analysis of the recorded experimental parameter changes. In this case, the evaporator is treated as a black-box. This allows for the inclusion of not only liquid and gas parameters, but also the thermal capacity of the heat exchangers and manifold. The model is elaborated to assess the influence of the following factors on the amount of mass evaporated: the steam mass flow rate m_{pi} ; raw juice inflow m_{si} ; pressure after heat exchanger; the inlet juice sugar mass fraction; the cooling water mass flow rate and temperature of the condenser. An example of such a function is displayed in Fig. 3. Similar relationships can be found also in the literature [5].

The function shape is heavily dampened however, the oscillatory character at the beginning of the curve is clearly visible. This function can be described by mathematical formulae of the first or second order Laplace transformation:

$$G(s) = K \frac{e^{-\Delta\tau s}}{1 + \zeta \cdot s}, \quad G(s) = K \frac{\omega^2 \cdot e^{-\Delta\tau s}}{s^2 + 2\zeta\omega s + \omega^2} \quad (6)$$

where:

- K – coefficient of the linearised response,
- $\Delta\tau$ – time delay,
- ζ – damping coefficient,
- ω – free frequency.

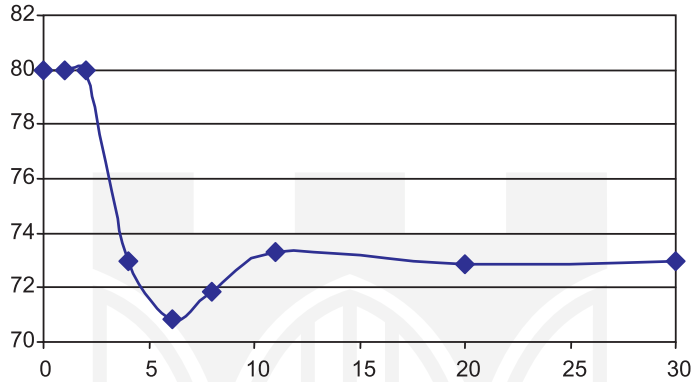

Fig. 3. Registered by the author, influence of the steam supply reduction on the outlet vacuum level in [%] with respect to time [min]

On the basis of the analysis of the registered functions, the dynamic model of the evaporator can be formulated. The graphical method for the determination of the coefficient using registered function in time is presented in Fig. 4. Additional definitions are needed:

$$\zeta = \frac{-\log M}{\sqrt{\pi^2 + (\log M)^2}}, \quad \omega = \frac{2}{T} \sqrt{\pi^2 + (\log M)^2} \quad (7)$$

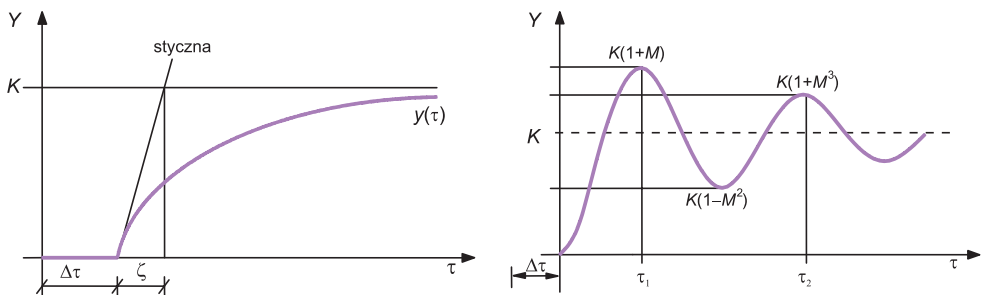

Fig. 4. Determination of the basic transform parameters using graphical approach

4. Evaporator control design

The evaporator control system has to meet the following conditions:

- assuring long and steady state evaporator work including consideration to the fact that during operation, external weather conditions (humidity and temperature) may change. Other problems, for example the possible fouling of the heat exchangers surfaces, also have to be considered;
- possibility of controlled operation within the range between nominal and minimal desired evaporator load;
- all non-desired states of the evaporator have to be reported to the operators;
- ease of operation for evaporator crew has to be ensured.

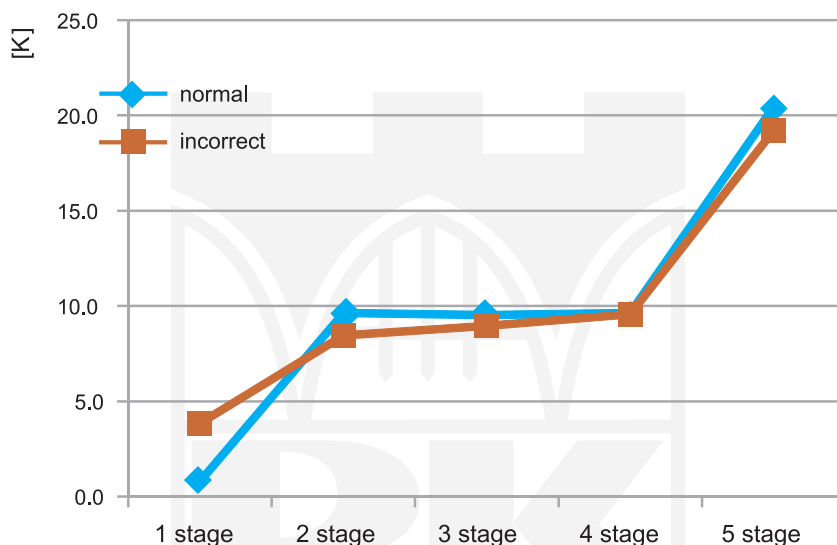

Fig. 5. Temperature differences during normal and incorrect operation

The vacuum control within the condenser is one of the issues because it depends on the ambient conditions. Over the course of a season the cooling water temperature for the condenser may vary within 5–30°C. In consequence, the condenser temperature may change within the range 20–55°C. This results in a condensing pressure change within the range 3–17 kPa (97–83% vacuum). For apple juice concentration, the available temperature difference on the evaporator is within the range 43 K–78 K. This means $60 \text{ K} \pm 18 \text{ K}$. The vacuum pump control is important because its main role is the removal of the non-condensing gases. If the assumed pressure resulting from condensing temperature is too low, then the total heat transfer process in the evaporator may collapse. Fig. 5 shows the distribution of the total available temperature difference of five evaporator stages. The incorrect temperature distribution is close to normal operation. In this specific case incorrect operation has been as of a result of heat exchanger fouling on stage I. The same result may be due to a non-condensing gases film forming on the surface.

5. Conclusions

Evaporator design and operation requires solution to the following issues:

- a) Heat transfer rates for each evaporator stage are determined with no more than 20% accuracy. The design has to take into consideration the minimum juice flow needed to cover internal tube surface;
- b) It is necessary to implement ambient condition compensation into the evaporator control algorithm;
- c) The control algorithm also has to consider dynamic conditions which occur during evaporator start up, shut down and parameter changes. In the algorithm, a time delay has to be introduced based on experimental tests. The oscillations of temperature functions have to be used for delay coefficient determination;
- d) The control system has to consider the fact that the evaporation is always determined by the worst stage.

References

- [1] Kubasiewicz P., *Wyparki. Konstrukcja i obliczanie*, WNT, Warszawa 1997.
- [2] Lewicki P. i in., *Inżynieria procesowa i aparatura przemysłu spożywczego*, WNT, Warszawa 2005.
- [3] Aly N.H., Marwan M.A., *Dynamic response of multi-effect evaporators*, Desalination 114, 1997, 189-196.
- [4] Aprea C., Renno C., *Experimental analysis of a transfer function for an air cooled evaporator*, Applied Thermal Engineering, 21, 2001, 481-493.
- [5] Cyklis P., Żelasko J., *Optymalne sterowanie procesami wymiany ciepła i masy w wielostopniowej wyparce cienkwarstwowej*, XIII Sympozjum Wymiany Ciepła i Masy, 2007, 379-386.
- [6] Cyklis P., *Dynamika pracy wielostopniowej wyparki cienkwarstwowej z opadającym filmem cieczy*, Materiały konferencyjne IV Warsztatów „Modelowanie przepływów wielofazowych w układach termochemicznych, Stawiska 2007.
- [7] Hoffman P., *Plate evaporators in food industry – theory and practice*, Journal of Food Engineering, 61, 2004, 515-520.
- [8] Jariel O., Reynes M., Courel M., Durand N., Dornier M., *Comparison de quelques techniques de concentration des jus de fruits*, Fruits, vol. 51 (6), 2007, 437-450.
- [9] Stefanov Z., Hoo K.A., *Control of a Multiple-Effect Falling-Film Evaporator Plant*, Ind. Eng. Chem. Res., 44, 2004, 3146-3158.
- [10] VDI – Wärmeatlas Berechnungsblätter für den Wärmeübertragung, *VDI-Verlag*, GmbH, Dusseldorf 1977.
- [11] Lovett D.J., Mackay M.E., *Improving Quality and Profitability with Evaporators and Dryers using Advanced Control Technology* (www.cidip.com).
- [12] www.sugartech.co.za/rapiddesign/juiceheater/index.php.
- [13] www.cheresources.com.