

Piotr Duda (pduda@mech.pk.edu.pl)

Łukasz Felkowski

Department of Thermal Power Engineering, Faculty of Mechanical Engineering, Cracow  
University of Technology

## AN ANALYSIS OF THE STEAM SUPERHEATER COIL OPERATION DEPENDING ON DIFFERENT METHODS OF COIL SUPPORT

---

### ANALIZA PRACY WĘŻOWNICY PRZEGRZEWACZA PARY PRZY RÓŻNYCH METODACH JEJ UTWIERDZENIA

#### Abstract

The paper presents the main types of power boiler steam superheater loads together with relevant standards applicable to superheater calculations. In the case of horizontal superheaters, due to their thermal expansion and assembly errors which are the effect of non-uniform support of the hanger tubes, extra loads are generated on the coil pipes. An FEM analysis performed for a selected superheater structure indicates that maximum stress values and the location where the stresses occur depend on the method of support of the superheater tubes. It is shown that maximum stresses in this structural element can be reduced by introducing appropriate tension of hanger bars supporting the superheater hanger tubes.

**Keywords:** power boiler, creep, stress, FEM analysis

#### Streszczenie

W artykule przedstawiono główne rodzaje obciążeń przegrzewacza pary kotłów energetycznych oraz normy obowiązujące przy ich obliczeniach wytrzymałościowych. W przypadku przegrzewaczy poziomych, ze względu na ich rozszerzalność cieplną oraz błędy montażowe spowodowane nierównomiernym zawieszeniem rur przegrzewacza następuje generowanie dodatkowych obciążeń na rurach wężownicy. Wykonana analiza MES dla wybranej konstrukcji przegrzewacza wykazała zależność maksymalnych naprężeń i ich miejsca występowania od sposobu zawieszenia rur przegrzewacza. Pokazano, że wprowadzenie odpowiednich naciągów w prętach wieszakowych podtrzymujących rury wieszakowe przegrzewacza może obniżyć maksymalne naprężenia w tym elemencie konstrukcyjnym.

**Słowa kluczowe:** kotły energetyczne, pełzanie, naprężenia, analiza MES

## 1. Introduction

A large proportion of damage to boiler heating surfaces, including superheater steam coils, is due to material overheating and corrosion. But the coil fixing method is an equally important factor generating concentration of stresses, which has a substantial impact on the structural element time of a failure-free operation. Pressure and high temperatures lead to creep-related damage, changes in material structure and cracks, thus making further operation of the superheater impossible. Experience shows that after the assumed period of operation, individual elements – though operated in conditions which comply with design calculations – are also affected by slight, safe, creep-related strains in areas where no concentration zones arise [1]. In places with the highest stresses and strains, on the other hand, deformations caused by the creep phenomenon are difficult to predict.

The paper presents results of thermal and strength calculations performed for a horizontal superheater whose task is to dry steam and raise its temperature to a required level. In this type of structure, superheater coils need to be supported using hanger tubes. Superheater heating surfaces are made of a large number of coils with pipes made of austenitic steel (due to their exposure to high temperatures exceeding 550 [°C]) [2]. The results of numerous calculations and experiments indicate that for such a temperature range the use of austenitic steels is justified as, unlike most other steel grades, they ensure acceptable values of the superheater coil wall thickness [3, 4].

## 2. Requirements of European standards

The standards concerning boiler pressure element calculations are usually specified for loads resulting from pressure. But the impact of other loads should also be taken into consideration by the designer. In the case of horizontal superheaters, due to thermal expansion affecting them and the hanger tubes, and due to assembly irregularities which are the effect of non-uniform support of the superheater tubes, extra loads are generated on the coil pipes. These loads must be taken into account both at the design and the operation stage [5].

If pipelines operate in creep conditions, longitudinal stresses caused by calculation pressure  $P$ , resultant moment  $M_A$  related to mass and other long-term loads, and resultant moment  $M_C$  related to thermal elongation should satisfy the following equation [6]:

$$\sigma_s = \frac{p d_o}{4 e_{ord}} + \frac{0.75 i M_A}{Z} + \frac{0.75 i M_C}{3 Z} \leq f \quad (1)$$

The stresses calculated according to formula (1) are used to present the results of a thermal and strength analysis performed in the Bentley AutoPipe program. According to the EN 13480-3 Standard (for the creep range), only a third of stresses arising due to thermal elongation is taken into consideration because it is assumed that the other two thirds are released in the relaxation process [6]. The values of the stress increase factor  $i$  (including the reduction factor of 0.75) should be higher than or equal to 1.0 ( $0.75 i \geq 1.0$ ).

The allowable stress after an extended period of operation  $f_{CR}$  – should take account of the creep phenomenon. It depends on the temperature and time of operation. The allowable stress value for creep is established according to Standard EN 13480-3 [6] or Standard EN 12952-3 [7], and it is calculated as  $f_{CR} = S_{RtC} / S_{fcr}$ , where  $S_{RtC}$  is the creep rupture strength and  $S_{fcr}$  is the safety factor. If the design service life is specified as a period of 100,000 h to 200,000 h, and if a service life monitoring system is provided, the safety factor  $S_{fcr}$  value of 1.25 may be used.

### 3. Numerical analysis

The SH3 steam superheater under analysis is an element of the boiler installation presented in Fig. 1, where all 44.5x6.3 pipes of steam coil 1 are supported on 44.5x6.3 hanger tubes 2 by means of hanger straps [8]. The pipes of the steam coils are anchored in membrane wall 3 in all directions:  $DX, DY, DZ, \phi X, \phi Y, \phi Z$ .

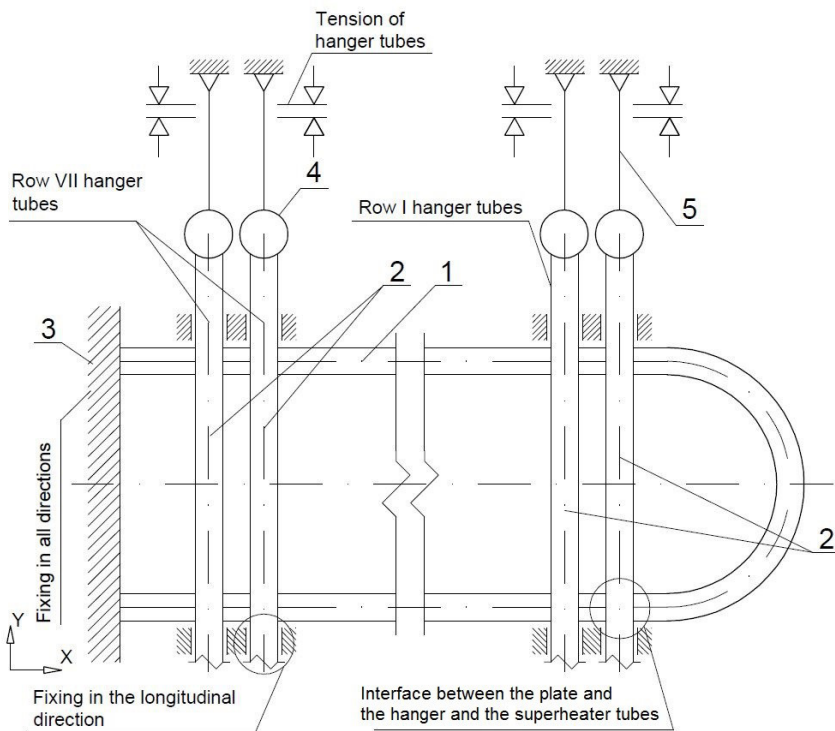

Fig. 1. Diagram of superheater SH3

Hanger tubes 2 are welded to chambers 4 hanging from hanger bars 5 in the structure grid. Tension of the bars can be adjusted to compensate for thermal elongation of the hanger tubes and to remove possible assembly irregularities. The adjustment and the measuring

methods depend on the technical solution adopted by the designer [2, 8, 9]. Superheater SH3 calculation temperature  $T$  is 604 °C, whereas calculation pressure  $P$  acting on the inner surface of the tubes is 284 bar.

The numerical analysis in the Bentley AutoPipe program is performed for two combinations of loads. The first enables an assessment of the coil stress-and-strain state for conditions in which the boiler is not operating, taking account of assembly irregularities. The second combination of loads makes it possible to assess stress concentration assuming a complete set of loads for an operating boiler with a variant with and without adjustment of the hanger bars.

### 3.1. First combination of loads

The analysis results are presented for loads resulting from the mass of the coil and the hanger tubes, and they take account of assembly irregularities introduced into the model in the form of preliminary displacement of the hanger tubes in direction  $DY = -58\text{mm}$ . The maximum stresses occur in point A shown in Fig. 2. They do not exceed allowable values in ambient temperature:  $f = 312/1.5 = 208 \text{ MPa}$ , and for point A they total  $\sigma_A = 202 \text{ MPa}$ .

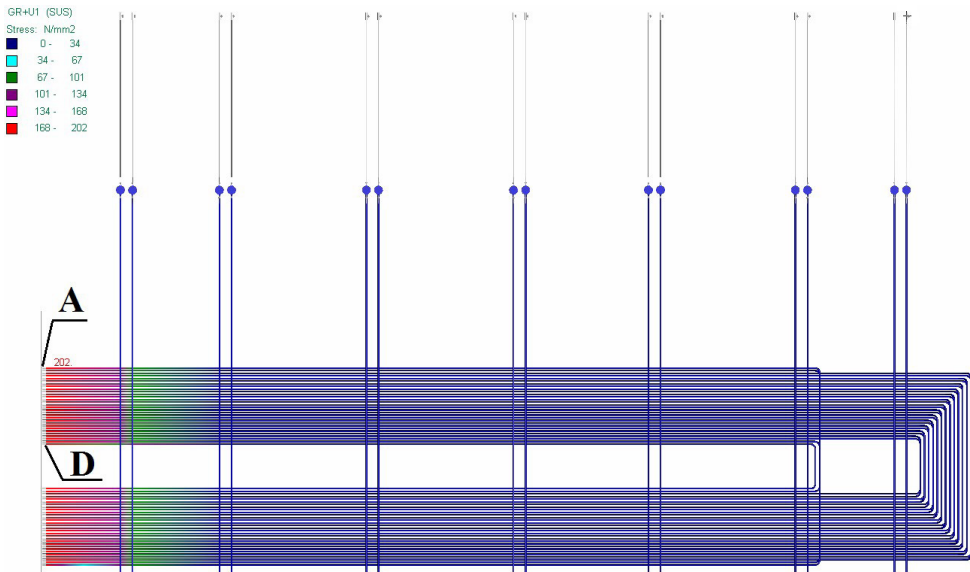

Fig. 2. Longitudinal stresses for the first combination of loads MPa

### 3.2. Second combination of loads

Fig. 3 presents the results of an analysis which takes account of the mass of the coil and the hanger tubes, calculation pressure  $P = 284 \text{ bar}$ , temperature  $T = 604 \text{ °C}$ , assembly irregularities and the variant with no tension of the hanger bars. The maximum stresses occur in point B:  $\sigma_B = 190 \text{ MPa}$  and exceed the allowable value of  $f_{CR} = 209.4/1.25 = 167.5 \text{ MPa}$ .

Stress concentration in point B is caused by the bending moment generated on the interface between the coil pipes and the membrane wall. The moment is an effect of thermal elongation of the hanger tubes of row VII (cf. 1) and a consequence of assembly irregularities taken into account in the analysis.

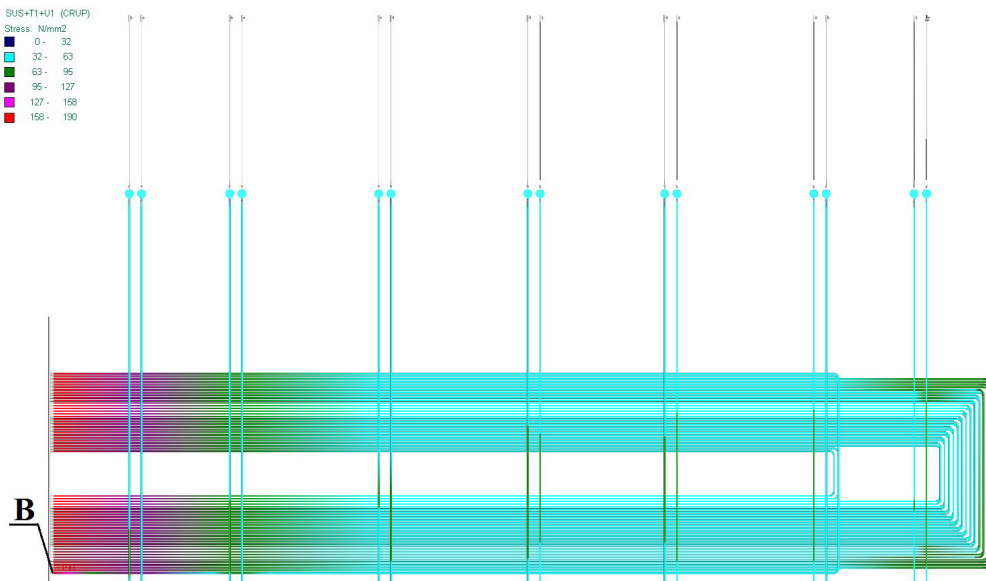

Fig. 3. Longitudinal stresses for the second combination of loads MPa; no tension of the hanger bars

If the calculations are performed taking account of the hanger bars tension as listed in Table 1, stress concentration in the superheater coil appears also in point B, as presented in Fig. 3.

Table 1. Tension adjustment values for the hanger bars

	Hanger tube rows						
	I	II	III	IV	V	VI	VII
Tension	27	29	29	29	29	30	40
DY [mm]	27	29	29	29	29	30	40

However, stresses in point B are lower and total  $\sigma_{B1} = 73$  MPa, which is 44% of the allowable value ( $\sigma_{B1} / f_{CR} = 0.44$ ). Stresses in the coil other areas are at the level of  $\sigma = 44 \div 75$  MPa and are also lower than the allowable value.

Introduction of tension of the hanger tubes has an impact on the stress state also if the coil is not loaded with pressure and temperature. Compared to the results obtained for the first combination of loads, the maximum stresses occur in point D (cf. Fig. 2) and total  $\sigma_D = 181$  MPa. The reduced concentration of stresses is the effect of adjustment of the hanger bars tension. The tension eliminates the non-uniform distribution of loads in the entire steam coil.

## 4. Conclusion

The paper presents a thermal and strength analysis of a steam superheater coil. It is shown that high stresses arise in this element mainly due to raised temperatures and assembly irregularities. The results indicate that the maximum stress values and the location where the stresses occur depend on the method of support of superheater tubes. It is shown that maximum stresses in this structural element can be reduced by introducing appropriate tension in the hanger bars which support superheater hanger tubes. The stress concentration zones indicated in the paper can be of help to make the decision which areas should be checked while operating horizontal superheater coils.

This research was financed by National Science Centre, Poland, UMO-2015/19/B/ST8/00958.

## References

- [1] Dobosiewicz J., Zbroińska-Szczechura E., *Ocena stopnia zużycia ciśnieniowych elementów kotłów pracujących w warunkach pełzania*, Energetyka, 12/2007, 917–922.
- [2] Laudyn D., Pawlik M., Strzelczyk F., *Elektrownie*, WNT, 1997.
- [3] Dobrzański J., Zieliński A., Pasternak J., Hernas A., *Doświadczenia z zastosowania nowych stali do wytwarzania elementów kotłów na parametry nadkrytyczne*, Prace IMŻ 62/1, 2010, 51–60.
- [4] Wala T., Hernas A., *Dobór materiałów na przegrzewacze referencyjnego kotła nadkrytycznego*, Prace IMiUE Politechniki Śląskiej, Book 23, Vol. III, 2009, 221–237.
- [5] Sertić J., Kozak D., Konjatić P., Kokanović M., *Analytical and numerical investigation of elastic-plastic behaviour of the connecting pipes between header and steam superheater*, Proceedings of the 6<sup>th</sup> International Congress of the Croatian Society of Mechanics, Edited by Smojver, I., Sorić, J., Zagreb the Croatian Society of Mechanics, 2009. 119.
- [6] EN 13480-3 Metallic industrial piping. Design and calculation.
- [7] EN 12952-3 Water-tube boilers and auxiliary installations.
- [8] Felkowski Ł., Duda P., *Analiza cieplno wytrzymałościowa węzownicy przegrzewacza pary, Analiza systemów energetycznych*, edited by: Węglowski B., Duda P., Wydawnictwo Politechniki Krakowskiej, Kraków 2013, 387–401.
- [9] Renowicz D., Plaza M., Plaza B., Renowicz E., *Measurement and force adjustment in boiler suspensions and other statically indeterminate mechanical systems*, the 14<sup>th</sup> International Research/Expert Conference, Trends in the Development of Machinery and Associated Technology TMT 2010, Mediterranean Cruise, 11-18 September 2010.