

VOLODYMYR SAMOTYY*, ANDRII PAVELCHAK**,
ULYANA DZELENDZYAK**

THE METHOD SELECTION OF CONTROL SYSTEM'S PARAMETRIC OPTIMIZATION

WYBÓR METODY OPTIMALIZACJI PARAMETRYCZNEJ SYSTEMÓW STEROWANIA

Abstract

In this article the methods' review of a control system's parametric optimization have been performed. According to the revealed analysis, the genetic algorithms have been chosen as the most appropriate tools for these tasks. Using genetic algorithms, the global optimum could be identified. To demonstrate it the system's parametric optimization, which consists of controlled three phase half wave rectifier and DC motor with independent excitation has been executed, using a classic genetic algorithm.

Keywords: evolutionary algorithms, DC motor, controlled three-phase rectifier, PID-regulator

Streszczenie

W artykule rozpatrzono przegląd metod optymalizacji parametrycznej systemów sterowania. Analiza wykazała, że najbardziej odpowiednią dla takiego rodzaju zagadnień są algorytmy genetyczne, ponieważ umożliwiają obliczenie optimum globalnego. Dla ilustracji realizowano optymalizację parametryczną układu: sterowany trójfazowy prostownik jednopółokwowy – silnik prądu stałego z niezależnym wzbudzeniem, na podstawie klasycznego algorytmu genetycznego.

Słowa kluczowe: algorytm genetyczny, silnik DC, trójfazowy prostownik sterowany, regulator PID

* Prof. D.Sc. Ph.D. Eng. Volodymyr Samotyy, Department of Automation and Information Technologies, Faculty of Electrical and Computer Engineering, Cracow University of Technology.

** Assoc. Prof. Ph.D. Eng. Andrii Pavelchak, Assoc. Prof. Ph.D. Eng. Ulyana Dzelendzyak, Department of Computerized Automatic System, Lviv Polytechnic National University, Ukraine.

1. Introduction

The problem of parametric optimization is not new. Its algorithms' realization could be used for an enterprise's costs optimization, traffic interchanges, models of people's life, animals' population in farms. Also it should be performed for mathematical models' parameters selection, control's rules, cryptography, approximation tasks and others. In fact the abilities of using optimization algorithms are limited only by scientist's imagination. The essence of the parametric optimization task is to find some parameters, using which the local and global optimum will be received for target function. For this reason, the last is the most significant result. The parametric optimization of control system gives an opportunity to design it in the best way for its responsibility to the quality criteria. The process of optimization method selection depends on the amount of information about exploration object, its mathematical model, linearity or nonlinearity and other factors. If the methods depend on exploration of an object some methods such as evolutionary methods can be used for the most widespread fields of tasks.

In our article the parametric optimization for DC motor control system has been performed by genetic algorithm. In fact this article is a continuation of a previous one [1] with contribution of controls' system modifications.

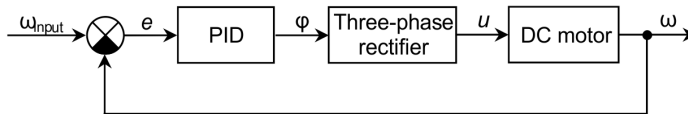

Fig. 1. Structural scheme of DC motor's control system

In system (Fig. 1) the DC motor with independent excitation in which the winding is fed on a separate source of DC voltage has been chosen as an element of control. The feed of the anchor's windings is executed by the thyristor's constant voltage rectifier to alternating voltage. The power of armature windings and motor control is executed by the thyristor's rectifier AC voltage to DC voltage. To reduce feeding voltage pulsations the three phase half wave rectifier was chosen. It gives an opportunity to improve the dynamic characteristics of control system. A DC motor has been connected to a rectifier using a capacity filter, which provides the filtration of the output voltage pulsation of the rectifier.

The regulation of DC motor's speed is executed using a PID-regulator, which is algorithmically realized in the existing microcontroller. The microcontroller receives the meaning of the anchor's speed rotation ω using an incremental encoder, which is connected to the motor's billow and it is compared with set value ω_{input} . Accuracy regulation e , as a difference between this meaning is transmitted on a PID-regulator. Rework set regulation e , the regulator forms the angels of late opening thyristor's valves ϕ . Thus, we change the voltage meaning in the output rectifier and accordingly the angle of the DC motor's valve rotation is also changed. The developed mathematical model of this system gives an opportunity to explore the parameter's impact on the system's work and the parametric optimization of the output system's mechanic characteristics can be executed using genetic algorithms.

2. Analysis of publications

In automatic control's general theory the regulator type is chosen depending on the model of a control object. In our case, the PID regulator has been selected. The most complicated part in PID regulator realization is the process of the coefficient K_p, T_i, T_d selection.

The methodology of PID regulator parameters was proposed by Ziegler and Nichols for the first time in 1942. Two methods of PID regulator were suggested [11]. The first method was based on the parameters of a control's object output signal during the single signal input. The second method based on object's frequency characteristics. The different approach has been proposed in a CHR method [12]. The maximum speed increase criteria could be used if the overshoot does not exist or the overshoot takes no more than 20 percent. In comparison with the Ziegler-Nichols method it has larger reserve of resistance. The methods are easy but it does not provide the sufficient accuracy of regulator's settings.

To increase the precision the regulator's synthesis has been occurred. The regulator parameters are calculated based on the system's model. The approximation of object dynamic by the model of the first and second order occurs with delay. It does not give an opportunity to provide an analytical solution of the equation's system and consider the nonlinear characteristics of control object, which is important during the higher stage model's solution.

The manual selection of PID regulator parameters is frequently used. It is the method of mistakes and attempts. To improve the process of parameters research rules based on experience the theoretical analysis and numerous experiments are used.

To take into account all specifics, especially the nonlinearity of control's object, the numeric methods of optimization should be used. It gives an opportunity to customize the regulator's parameters optimally for the different complexity models. During the process of establishing PID regulator parameters the optimization methods execute the minimization for the quality criteria or even complex criteria consisting of several criteria with different weight coefficient. To receive the necessary form of output characteristic some limits ought to be imposed. The optimization methods give an opportunity to receive an accurate meaning of PID regulator and it does not need the control system simplification. Despite this, these methods could have the continued process of minimum research.

The optimization algorithms used for optimal control system determination have been divided into two classes: deterministic and probabilistic [2]. In each step of deterministic algorithm execution the single variant for its work duration could be used. If it is absent the algorithm will finish its work. Usually for the same input data the deterministic algorithm proposes the same results. But, sometimes, the situation could occur where deterministic algorithms find only a local optimum. If the feedback between the received result and its suitability is not obvious, it changes dynamically, or becomes too complicated, so the usage of the most deterministic approach is not effective. In such situations the probability algorithms could be performed. Usually, the accurate algorithms could be much more effective than probability algorithms in large amount of areas. Moreover, the probability algorithms have an additional disadvantage, it could cause different results when launching the same data.

Between deterministic algorithms [3, 4] the following method's group could be chosen: State space search, the method of Branch and bound, Cutting-plane method and others.

Between probability algorithms the following methods could be chosen [5]: Hill climbing algorithm, Cutting-plane method, Tabu Search, method of extremal optimization, Downhill simplex method. The probability algorithms should be marked as a separate group [5–8]: genetic algorithms, evolutionary strategies, genetic programming, evolutionary programming, differential evolution, the algorithm of division estimation.

During PID parameters optimization the local optimums ought to be exist, so the usage of deterministic methods have not been appropriated. For example, the method of gradient descent gives an opportunity to find the global optimum for convex function. The existing probability optimization methods have been analyzed and genetic algorithms have been chosen as the most optimal solution for our task.

3. The mathematical model of control system

The model of a DC motor's control system with independent excitation, which was explored in the previous article [1], was insignificantly changed. Instead the tachogenerator incremental encoder had been used (Fig. 2). Also additional resistance to the anchors windings and the motor's stator was connected. This resistance is appropriated to quality improvement of motor's dynamic characteristics.

Because the full derivation of dynamic equation for three phase half wave rectifier and DC motor with independent excitation was shown in [1], the final equations would be performed in this article. The parameters of secondary windings have been led to the primary parameters by the amount of wind.

In normal Cauchy form the equation's condition of three phase half wave rectifier has the following performance:

$$\frac{dX}{dt} = BZ(t), \quad (1)$$

where:

$$X = (\psi_A, \psi_B, \psi_C, i_{2A}, i_{2B}, i_{2C}, u_C)^T, \quad B = \text{diag}(M, 1/C), \quad M = (D^{-1}\Lambda, A)^T,$$

$$D = P + \alpha_0 \cdot E_{33} + \alpha_1 + \alpha_2, \quad P = \text{diag}(\alpha''_A, \alpha''_B, \alpha''_C), \quad \Lambda = (\alpha_1, \alpha_2),$$

$$\alpha_1 = \text{diag}(\alpha_{1A}, \alpha_{1B}, \alpha_{1C}), \quad \alpha_2 = \text{diag}(k_A \alpha_{2A}, k_B \alpha_{2B}, k_C \alpha_{2C}),$$

$$A = (-\alpha_2 D^{-1} \alpha_1, \alpha_2 (E - D^{-1} \alpha_2)), \quad E_{33} = (E_3, E_3, E_3), \quad E_3 = (1, 1, 1)^T,$$

$$Z(t) = (U - RI, i_{2A} + i_{2B} + i_{2C} - i_a)^T, \quad U = (u_{1A}, u_{1B}, u_{1C}, -u_C, -u_C, -u_C)^T,$$

$$R = \text{diag}(r_{1A}, r_{1B}, r_{1C}, r_{2A}, r_{2B}, r_{2C}), \quad i = (i_{1A}, i_{1B}, i_{1C}, i_{2A}, i_{2B}, i_{2C})^T,$$

$$i_{1j} (j = A, B, C) = \varphi(\psi_j) + \alpha_0 \cdot (\psi_A + \psi_B + \psi_C) - i_{2j}.$$

Values determination: u_{1A}, u_{1B}, u_{1C} is the input three phase voltage; Ψ_A, Ψ_B, Ψ_C is the working linkage phase; $i_{1A}, i_{1B}, i_{1C}, i_{2A}, i_{2B}, i_{2C}$ is the working winding's current of primary

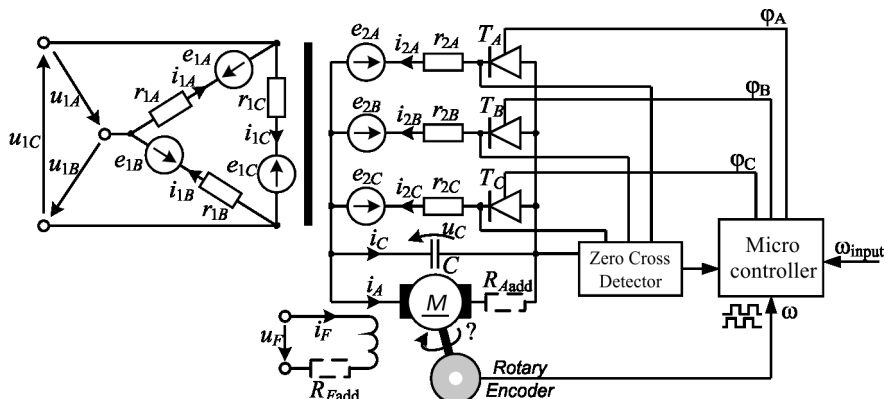

Fig. 2. Control system of DC motor with independent excitation

and secondary transformer's; $r_{1A}, r_{1B}, r_{1C}, r_{2A}, r_{2B}, r_{2C}$ is the transformer windings' resistance; $\alpha_{1A}, \alpha_{1B}, \alpha_{1C}, \alpha_{2A}, \alpha_{2B}, \alpha_{2C}$ is the inverse scattering windings' inductance; $\varphi(\Psi_A), \varphi(\Psi_B), \varphi(\Psi_C)$ is the magnetic voltage in the transformer's core, determined by its magnetization curves; α_0 is the inverse inductance of zero sequence scattering; C is the filter capacitor; k_A, k_B, k_C is the additional logical changes, which could receive the meaning 0 or 1.

The thyristors would be opened if the additional voltage was higher than the voltage of the thyristor's inclusion and administer microcontroller's permission signal:

$$-\frac{d\Psi_i}{dt} - u_c > U_{ON}; \quad i = A, B, C. \quad (2)$$

In our model the simplifications were introduced and charged with the minimal anode voltage. Using it the thyristor will switch on and it will be equal to zero $U_{ON} = 0$.

If the microcontroller does not manage the input voltage of thyristor's rectifier it usually ought to pass the permission signal on thyristors' work will be determined only by the condition (2). In our mathematical model the permission signal of thyristors' open are modeled by logical variables. k_A, k_B, k_C . If it is necessary to model output voltage of the thyristor's rectifier for microcontroller in determined time moments it should pass the control signals on thyristors. The additional detection modulus of zero intersection determines the points of intersection (from negative to positive area) for all thyristors.

Then, the administer microcontroller using peripheral timers account for the necessary holdbacks for the thyristor's opening. For example if a frequency of input voltage 50 Hertz and the angle of the holdback thyristor's opening is 30° the time of holdback is $\Delta\tau = 30^\circ / (50 \cdot 360^\circ) \approx 1.67$ msec. So, the microcontroller individually for each phase pass the administer signal for this thyristor's opening after its zero intersection. The administer

signal is decontaminated during the part of time equal to period's half of input signal minus $\Delta\tau$. Also this interval of time is accounted by peripheral timers of administer microcontroller.

Thyristors are closed if the administer signal is absent and if the current is less than current of thyristor's hold.

$$i_{2i} = 0, \quad \frac{di_{2i}}{dt} < 0; \quad i = A, B, C. \quad (3)$$

In mathematical model the thyristors' are closed if condition (3) is performed, the additional variables get the meaning $k_i = 0$. During modeling when the current is $i_{2i} \leq 0$, then the additional logical variables assigned $k_i = 0$ and the current is established in zero.

The mathematical model of control system, apart from the seven condition equations of three phase half wave rectifier, includes two differential equations for DC motor and one equation of movement.

The differential current's equations of DC motor winding with independent excitation are shown as:

$$\frac{di_A}{dt} = S_A \cdot u_C + T_A \cdot u_F + E_A, \quad \frac{di_F}{dt} = T_F \cdot u_C + S_F \cdot u_F + E_F, \quad (4)$$

where:

$$S_A = 1 / (L_A + L_{AF}L_{FA} / L_{FF}), \quad T_A = -S_A L_{AF} / L_{FF}, \quad T_F = -S_A L_{FA} / L_{FF},$$

$$E_F = -(L_{FA} \cdot E_A + (r_F + R_{Fadd}) \cdot i_F) / L_{FF}, \quad S_F = (1 - L_{FA} \cdot T_A) / L_{FF},$$

$$E_A = S_A (L_{AF} \cdot (r_F + R_{Fadd}) \cdot i_F / L_{FF} - c \cdot \omega \cdot \Phi - \Delta u - (r_A + R_{Aadd}) \cdot i_A).$$

The description of values: L_A – is the summary inductance of series anchor's circle; L_{FF} is the inductance of excitation winding; L_{AF} , L_{FA} are the mutual inductances of the anchor's circle and excitation circle; ω is the angle speed of anchors rotation; Φ is the magnetized motor's flow; c is the constructive anchor's stable MPC; Δu is voltage reduction in brush contact.

In compensated motors the consideration of a magnetic conductor's saturation could be executed approximately by the magnetized curve $\Phi = \Phi(i_F)$, $L_{FF} = L_{FF}(i_F)$. In an unsaturated motor $\Phi = ki_F$, $L_{FF} = \text{const}$.

The dynamic equation is written according to Dalamber's equation:

$$\frac{d\omega}{dt} = (c\Phi i_A - \text{sign}(\omega) \cdot M_O) / J, \quad (5)$$

where:

J – a moment of a motor's rotor inertia,

M_O – a moment of resistance.

During D motor's work modeling the condition of the motor's rotation start is important

$$|c \cdot \Phi i_A| > M_O, \quad (6)$$

If condition (6) is not executed, the meaning $\omega = 0$ is charged.

4. Implementation of PID-controller

For this system of DC motor control it is necessary to keep some speed of motor's shaft according to charged meaning ω_{input} . The charged meaning could rapidly change in time. The PID-regulator is involved in the system. It is realized in administering the microcontroller. For algorithm implementation of PID-regulator its discrete form, in which continual integration is performed using the method of rectangles.

$$u(n) = K_p \cdot \left(e(n) + \frac{\Delta t}{T_i} \cdot \sum_{k=0}^n e(k) + \frac{T_d}{\Delta t} \cdot (e(n) - e(n-1)) \right), \quad (7)$$

where:

- Δt – a time of discretization,
- K_p – a proportional coefficient,
- T_i, T_d – constants of time integration and differentiation.

For control system the implementation of discrete PID-regulator has a range of specifics: it is necessary to limit the meaning of integrator's sum accumulation, to choose the form administer signal's presentation; to establish the additional limits on the range of control signal meanings. In this system the administer signal from entrance of PID-regulator is performed by the angle of holdback of thyristor's open. The particularity of DC motor control's system means that the DC motor's shaft will be rotated if the holdback's angle of thyristor's opening gets the meaning from 0 до 150°. This fact was fixed during of thyristor rectifier modeling. Taking in to account these comments the algorithmic implementation of discrete PID-regulator could be performed by this pseudocode:

```

error = inputOmega - currentOmega
integral = integral + error
if(integral > Imax) than integral = Imax
if(integral < Imin) than integral = Imin
derivative = (error - previous_error)
output = Kp * (error + dt / Ti * integral + Td / dt * derivative)
if(output >= 150) than angleThyristor = 0
else if(output <= 0) than angleThyristor = 150
else angleThyristor = 150 - output
previous_error = error

```

Before the first usage of PID-algorithm the variables *previous_error* and *integral* are performed by zero. The meaning of current mistake for each time is saved for repeated usage in following iterations of PID-algorithm. The meaning of time discreet *dt* is selected. It should have meaning less than 1/10 of constant meaning of transient objet characteristics. In this case for transient objet characteristic of rotation motor's spindle. In our case transitional characteristic is performed as a speed of motor's rotation. The meaning *dt* determines the periodicity of PID-algorithm download.

5. Implementation of genetic algorithm

The parametric optimization of this task is executed by classic binary genetic algorithm. [6, 7]. For optimization in binary genes the coding of chosen parameters are executed by quantization of possible parameters' meaning.

$$step_i = \frac{valueMax_i - valueMin_i}{2^n - 1}, \quad gene_i = \frac{param_i - valueMin_i}{step_i} \quad (8)$$

The inverse decode is executed by formula (9).

$$param_i = valueMin_i + gene_i \cdot step_i \quad (9)$$

In this algorithmic implementation the chromosome is performed by genes structures of unsigned whole data type. For parameters codation an arbitrary number of bits could be chosen. In this case it could be from 8 to 32 bits. The lower amount of bits gives an opportunity to cover the field of investigation more quickly. The larger amount provides better accuracy of investigation. For a genetic algorithm operator the developed algorithms could work only in chosen bits. The remaining bits in the gene structure have been established in zero and could be ignored:

The developed realization of binary genetic algorithm has the following sequence of actions:

1. *The creation of primary population with chromosomes initialization and fitness meaning calculations.* The engeneration of the binary strip is executed bit by bit using a randomizer. The primary amount of population depends on task type, which should be optimized. Theoretically, the larger amount of population will be occurred, the better result is received. But in practice the execution requires a significant time expenses. Then, in the process of genetic algorithm execution the amount of population could be reduced or increased. For our task the amount of population are 30–40 chromosomes, because the calculation of mathematical model's transcendent process is protracted operation. The calculation of fitness meaning is parallelized depending on the amount of physical and logical nucleus of PC's processor.
2. *Population's sorting by fitness meaning.* It is executed by the best fitness meanings (minimal or maximal). The best fitness meaning locates at the bottom of population. The worst fitness meaning locates in the beginning of population.
3. *Selection.* The chromosomes selection for population is executed by linear ranking:

$$Fitne\beta(Pos) = 2 - SP + 2 \cdot (SP - 1) \cdot \frac{Pos - 1}{Nind - 1} \quad (10)$$

where:

- $Nind$ – chromosomes' amount in population,
- Pos – chromosomes' position in population (the worst accommodated chromosomes have $Pos = 1$, the best accommodated chromosomes have $Pos = Nind$),
- SP – a pressure selection's coefficient, which reaches the meaning in limits [1; 2].

According to received meaning Fitness the amount of chromosome's inputs is determined. The additional best chromosomes' copies are compared with the worse replacement in the beginning of the population. During genetic algorithm's testing the coefficient *SPhave been shown as optimal* with the meaning 1.6–1.8.

1. *The elite chromosomes' selection.* The preset amount of the best chromosomes should be copied into intermediate buffer.
2. *Crossing.* The binary operator of crossing (crossover) is used. Mating is executed according to ranking. At the first time the best would be ranked then the worst would be ranked. In general the option when the best chromosomes are ranked with the worst chromosomes has given the worst result as the option of accidental chromosomes' selection for crossing.
3. *The fitness meaning calculation for received population after crossing.* The calculation of fitness meaning is parallelized and depends on amount of physical and logical nucleus of PC's processor.
4. *The sorting of population according to fitness meaning.* At this stage sorting is necessary for the most accommodated chromosome determination, which would not be mutated.
5. *Mutation.* For this procedure the percent of expectation in the whole population is defined. Based on this meaning the amount of bits, which should be mutated (inverted its meanings from 0 into 1 or vice versa) had been calculated. The structure of masks, where the positions of these bits have been determined casually, should be created. Firstly in population the chromosome's number is determined casually, than the number of bits will be determined. The masks' structure is added to the chromosomes' structure by labeled XOR operation. Thus, the inversion operation is executed. The most accommodated chromosome is excluded from the mutation procedure. During genetic algorithm testing the meaning of mutation percentage has been optimal in 1–5% limits.
6. *The fitness meaning calculation for mutated succession.* The calculation of fitness meaning is parallelized depending on the amount of physical and logical nucleus of PC's processor.
7. *Population's sorting by fitness meaning.* This step could be excluded if the elitism's meaning would be equal to 0.
8. *Elitism.* This procedure pastes selected chromosomes in 4 with worse chromosomes' changes in the beginning of population.
9. *Population's sorting by fitness meaning.*
10. *Population's copies creation.* These copies would be necessary if the optimum research continued using genetic algorithm. It is possible that during genetic algorithm some parameters could be changed as an optimization's object or as an algorithm. For example, some research limits ought to be replaced for investigated parameters. For this it is necessary to stop genetic algorithm's work, choose new parameters and continue optimization.
11. If the adjusted amount of the population was reworked the genetic algorithm's performance would be finished. If the genetic algorithm's performance wouldn't be finished step 3 has been executed. The genetic algorithm implementation was executed in C# language. Appropriately, the built-in integrator of pseudorandom numbers with equable divisions' law was used. NET Framework, based on subtractive algorithm of D. Knuta has been created. To fitness meaning parallelization the meaning's class Task

has been used. The genetic algorithm implementation was approved on the tests' task for optimization [10]: De Jong's function 1, Axis parallel hyper-ellipsoid function, Rotated hyper-ellipsoid function, Rastrigin's function 6, Schwefel's function 7. For all testes' tasks the realized algorithm has found determined function's minimum and maximum.

6. Results of control system optimization

For development of our system's mathematical model the program was written in C# and its dynamical process' simulation was executed.

The feeding voltage of three phase half wave rectifier was preset by expressions:

$$u_{1A} = U_m \sin(2\pi ft), u_{1B} = U_m \sin(2\pi ft - 2\pi / 3), u_{1C} = U_m \sin(2\pi ft + 2\pi / 3), \quad (11)$$

where:

$$U_m = 311 \text{ V}, f = 50 \text{ Hz}.$$

The calculations of the system's dynamic process have been executed by these meanings. Transformator's parameters:

$$r_{1A} = r_{1B} = r_{1C} = 2 \Omega; r_{2A} = r_{2B} = r_{2C} = 1 \Omega; \alpha_{1B} = \alpha_{1C} = 172 \text{ H}^{-1}; \alpha_{1C} = 172 \text{ H}^{-1};$$

$$\alpha_{2A} = \alpha_{2B} = \alpha_{2C} = 200 \text{ H}^{-1}; \alpha_{2B} = \alpha_{2C} = 200 \text{ H}^{-1}; \alpha_0 = 1.2 \text{ H}^{-1}; C = 9 \text{ mF}.$$

The magnetized curve was approximated by expression:

$$\varphi(\psi) = \begin{cases} m_1 \psi & \text{if } |\psi| > \psi_1 \\ S_3(\psi) & \text{if } \psi_1 \leq |\psi| \leq \psi_2; \\ m_2 \psi - m_0 & \text{if } |\psi| > \psi_2 \end{cases} \quad (12)$$

where:

$$m_1 = 0.25 \text{ H}^{-1}, m_2 = 3 \text{ H}^{-1}, \alpha_0 = 1.8 \text{ A}, \psi_1 = 0.2 \text{ Wb}, \psi_2 = 0.9 \text{ Wb},$$

$$\varphi(\psi_1) = 0.05 \text{ A}, \varphi(\psi_2) = 0.9 \text{ A}, S_3(\psi) \text{ is a cubic spline}.$$

DC motor's parameters:

$$L_A = 9.67 \text{ H}, L_{FF} = 110.8 \text{ H}, L_{AF} = L_{FA} = 0 \text{ H}, r_A = 33.2 \Omega, r_F = 173 \Omega,$$

$$J = 0.09 \text{ Nms}^2/\text{rad}, M_O = 4 \text{ Nm}, c = 70.8 \text{ Nm}/(\text{WbA}), u_f = 300 \text{ V}, k = 0.04.$$

On Fig. 3a the results of our system work simulation by DC motor without PID-regulator have been shown. The transient motor's characteristic has the overshoot before system's entrance into steady-state regime. On Fig. 3b condenser's voltage fluctuation has been shown in increase measure. These fluctuations consist $< 0.5 \text{ V}$ that's why it could be not taken into account.

On Fig. 4 the main dependences of control system without PID-regulator taken in steady-state regime were shown. The input voltage dependence u_c of filter's capacity rectifier on feeding voltage of three phase half wave rectifier has linear character. The dependence of DC motor's shaft speed rotation on input voltage also has a linear dependence (Fig. 4a). It is important to mark that voltage u_c for DC motor's start with independent excitation

and established parameters ought to have the meaning no less than 28 V. These values' dependences on angle of delays have a nonlinear character (Fig. 4b).

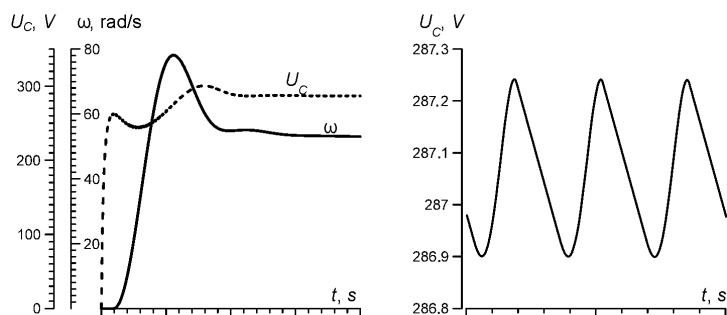

Fig. 3. Transient response of control system of DC motor without PID-controller

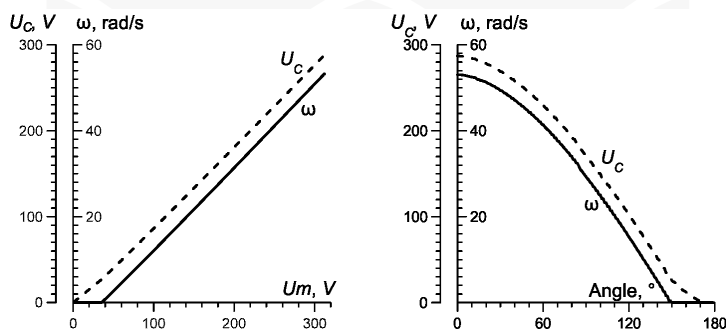

Fig. 4. Main dependences of control system without PID-controller

The parametric optimization of our control system has two components. The first predicates the improvements of dynamic characteristics using additional resistances R_{Add} , and the second predicates the selection of PID-regulator coefficients.

Using control system modeling it is established, that resistance R_{Add} reduces reregulation and the speed of DC motor's shaft will be also reduced. The resistance R_{Add} gives an opportunity to increase the speed.

For dynamic characteristic optimization of control system the described in chapter 5 genetic algorithms has been used. As the criteria for fitness function meaning the deviation of discrete instantaneous points on set meaning has been used. So, fitness-meaning is calculated by such a formula:

$$Fitness = \sum_i |\omega_{input} - \omega(t_i)|. \quad (13)$$

The control system modeling is executed by the Runge-Kutta method of fourth order. At the first investigation stage system's optimization is executed only for PID regulator parameters: K_p, T_i, T_d and the meaning of the integrator's commutation sum. Optimization

was executed for $\omega_{input} = 40 \text{ rad/s}$. At this stage it was charged that the optimal meaning for integrator's limit is ± 62 .

At the second investigation stage the system's optimization was executed by 5 parameters for which those limits was determined: $K_p = [0; 30]$, $T_i = [0; 1]$, $T_d = [0; 1]$, $R_{Aadd} = [0; 30] \Omega$, $R_{Fadd} = [0; 100] \Omega$. System's integration was executed during 4 seconds.

For genetic algorithm such settings have been chosen: 16 or 32 bites for gene's meaning quantization, the amount of population differs between 30–50 chromosomes, the probability of mutation differs in limits of 1–5%, pressure coefficient of selection was chosen as 1.7 or 1.8, for elitism 1 chromosome was chosen.

For optimized parameters $\omega_{input} = 40 \text{ rad/s}$ the dynamic characteristic of control system has a quality performance but for another determined meanings the dynamic characteristic becomes worse. So, it was decided to sum the fitness meaning for several ω_{input} (10 and 40 rad/s).

On Fig. 5 the transient processes were received and shown by genetic algorithm parameters meaning using: $K_p = 19.86$, $T_i = 0.172$, $T_d = 0.282$, $R_{Aadd} = 21,49 \Omega$, $R_{Fadd} = 66.63 \Omega$.

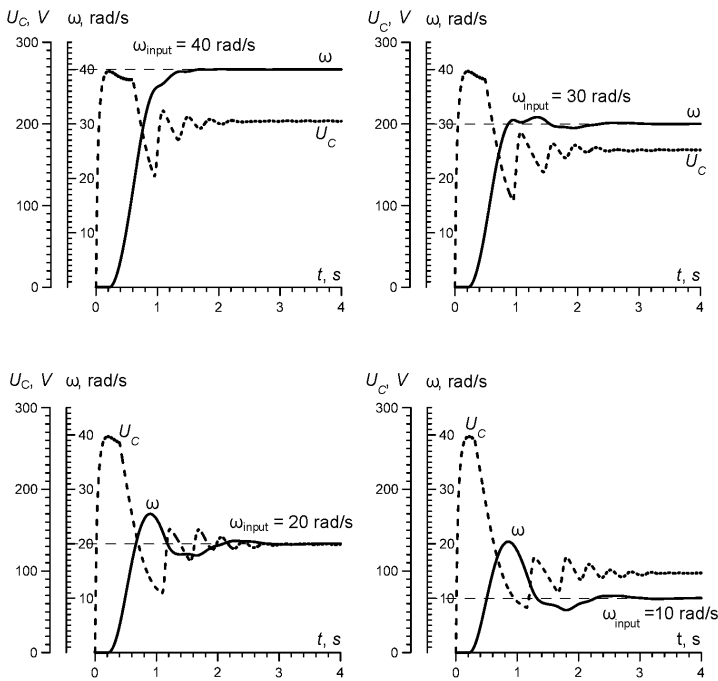

Fig. 5. Dynamic characteristics of the control system for different ω_{input}

On Fig. 6 the dynamic characteristics for optimized PID-regulator's coefficients and additional resistance have been shown. Determined meanings ω_{input} changed every 3 second (40, 10 and 30 rad/s). During this control system has been shown quality dynamic characteristic and stable character.

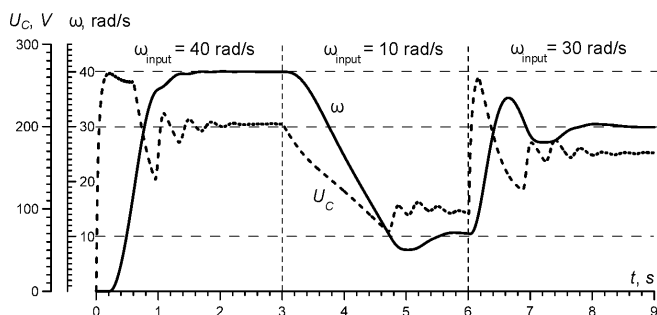

Fig. 6. Dynamic characteristic of the control system with change ω_{input}

7. Conclusions

Using the proposed mathematical model of thyristor control system of a DC motor's speed rotation with independent excitation the parametric optimization of control system has been executed. Using binary genetic algorithm the coefficients of PID-regulator and additional resistances for DC motor have been selected. The executed optimization gives an opportunity to receive the quality dynamic characteristics of DC motor's control system with independent excitation. The developed mathematical model of control system is universal and simple for algorithmization.

References

- [1] Samoty V., Dzelendzyak U., *Mathematical model of thyristor's system control of DC motor with independent excitation*, Technical Transactions, vol. 1-AC/2013, Cracow University of Technology Press, 2013, 79-91.
- [2] Chong E.K.P., Zak S.H., *An Introduction to Optimization*, 4th Edition, John Wiley & Sons, 2013.
- [3] Reiner Horst, Tuy Hoang, *Global Optimization: Deterministic Approaches*, 3rd edition, Springer-Verlag GmbH: Berlin, Germany, 1996.
- [4] Mordecai Avriel, *Nonlinear Programming: Analysis and Methods*, Dover Publications: Mineola, NY, USA, 2003.
- [5] Weise T., *Global optimization algorithms: theory and application*, 3rd Edition, Thomas Weise, 2011.
- [6] Sivanandam S.N., Deepa S.N., *Introduction to Genetic Algorithms*, Springer-Verlag Berlin Heidelberg, 2008.
- [7] Randy L. Haupt, Sue Ellen Haupt, *Practical genetic algorithms*, 2nd ed., John Wiley & Sons, Inc., Hoboken, New Jersey 2004.
- [8] Mitchell M., *An Introduction to Genetic Algorithms*, A Bradford Book The MIT Press, 1999.
- [9] Astrom K.J., Hagglund T., *Advanced PID control*, ISA - The Instrumentation, Systems, and Automation Society; Research Triangle Park, NC, 2006.
- [10] Hartmut Pohlheim, *Examples of Objective Functions*, 2006, www.geatbx.com.

