

WOJCIECH MYSIŃSKI, NATALIA PRAGŁOWSKA-RYLKO*

USE OF MIDDLEBROOK'S METHOD IN FREQUENCY ANALYSIS OF POWER ELECTRONIC CIRCUITS

WYKORZYSTANIE METODY MIDDLEBROOK'A DO ANALIZY CZĘSTOTLIWOŚCIOWEJ UKŁADÓW ENERGOELEKTRONICZNYCH

Abstract

The article presents Middlebrook's method, which allows one to obtain the frequency analysis of power electronic circuits based on time analysis. The authors carried out their simulations in LTspice. The article discusses selected examples of circuits, such as an active filter, a resonant RLC circuit and a Buck-Converter with a correction circuit. An important advantage of Middlebrook's method is that it allows for the determination of the amplitude and phase characteristics for nonlinear circuits, as opposed the common .AC method. Simulation tests of non-linear circuits indicate that, in order to obtain correct results using Middlebrook's method, the values of input signals need to be selected very carefully.

Keywords: Middlebrook's method, AC analysis, Buck-Converter

Streszczenie

W artykule przedstawiono metodę Middlebrook'a, która umożliwia otrzymanie charakterystyki częstotliwościowej, np. układów energoelektronicznych na podstawie analizy czasowej. Autorzy przeprowadzili badania symulacyjne w programie LTspice, aby sprawdzić zalety i wady tej metody. Wzięto pod uwagę kilka układów, takich jak filtr aktywny, obwód rezonansowy RLC oraz przekształtnik DC/DC obniżający napięcie z torem korekcyjnym. Zaletą metody Middlebrook'a jest możliwość wyznaczania charakterystyki amplitudowej i fazowej w przypadku obwodów nieliniowych w porównaniu do zwykłej metody .AC. Badania symulacyjne układów nieliniowych pokazują, że należy bardzo starannie dobrać wartości sygnału wymuszającego, aby uzyskać poprawne wyniki w metodzie Middlebrook'a.

Słowa kluczowe: Metoda Middlebrook'a, analiza częstotliwościowa, Buck-Converter

* Ph.D. Eng. Wojciech Mysiński, M.Sc. Eng. Natalia Pragłowska-Rylko, Institute of Electrotechnics and Computer Science, Faculty of Electrical Engineering and Computer Science, Cracow University of Technology.

1. Introduction

AC analysis is widely used in the case of electronic devices. One of the methods used to obtain frequency characteristics is Middlebrook's method. The significant advantage of this method is the retention of non-linear element characteristics, as compared with the classic AC analysis, which linearizes non-linear circuits, causing errors.

Middlebrook's method was published by R. David Middlebrook in 1975 in "Measurement of Loop Gain in Feedback Systems" [4]. Middlebrook's method determines frequency responses by employing time analysis (.TRAN analysis). The authors have added to the circuit a voltage sine source [2] which generates signals with the same amplitude but a different frequency for each iteration (for each .TRAN). The number of iterations is defined by a frequency step change. All sine signals have the same period number, but different duration and the stop time for each .TRAN analysis is different. The amplitude of sine signals determines the noise level [7].

In order to determine the frequency response of circuits, Middlebrook's method uses measured time-dependent values, frequency step changes and signal recalculations from the time domain to the field of complex. To obtain the frequency characteristics, the authors defined two measurement points *a* and *b* (as in Fig. 1) [3]. The location of the points depends on the location of circuit elements influencing the frequency characteristics.

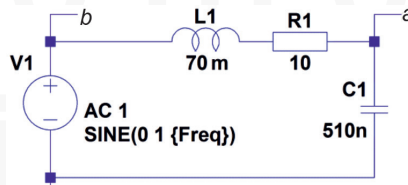

Fig. 1. Simple RLC resonant circuit

2. Middlebrook's method in LTspice

In Middlebrook's method frequency characteristics are based on the .TRAN analysis. Voltage values in points *a* and *b* are saved using the LTspice formula `.save V(a) V(b)`.

The LTspice uses the following formulas, described below [1, 4, 5].

$$\begin{cases} \text{.tran 0 } \{5 / \text{Freq} + 0.1 \text{ m}\} 0.1 \text{ m} \\ \text{.step dec param Freq 10 10k 10} \end{cases} \quad (1)$$

The analysis declaration defines the .TRAN analysis and frequency step change of input signal using the global parameter „Freq”.

$$\begin{cases} \text{.measure Aavg avg } V(a) \\ \text{.measure Bavg avg } V(b) \end{cases} \quad (2)$$

The first two above formulas allow us to measure mean voltage values in points a and b (3) for each. TRAN analysis.

$$\begin{cases} A_{avg} = \bar{V}(a) \\ B_{avg} = \bar{V}(b) \end{cases} \quad (3)$$

where:

A_{avg}, B_{avg} – mean voltage values in points a and b ,
 $V(a), V(b)$ – output and input voltage.

The next formulas eliminate the DC component from voltage signals (subtracting the mean voltage signal value from the current voltage value).

$$\begin{cases} \text{.measure Are avg } (V(a) - A_{avg}) \cdot \cos(360 \cdot \text{time} \cdot \text{Freq}) \\ \text{.measure Aim avg } - (V(a) - A_{avg}) \cdot \sin(360 \cdot \text{time} \cdot \text{Freq}) \\ \text{.measure Bre avg } (V(b) - B_{avg}) \cdot \cos(360 \cdot \text{time} \cdot \text{Freq}) \\ \text{.measure Bim avg } - (V(b) - B_{avg}) \cdot \sin(360 \cdot \text{time} \cdot \text{Freq}) \end{cases} \quad (4)$$

In the same step, the following equations transform the signals from the time domain to the field of complex (5). The LTSpice formulas convert the signals in points a and b to location vector with defined real and imaginary part, as shown below:

$$\begin{cases} A_{re} = \overline{(V(a) - \bar{V}(a)) \cos(2\pi tf)} \\ A_{im} = -\overline{(V(a) - \bar{V}(a)) \sin(2\pi tf)} \\ B_{re} = \overline{(V(b) - \bar{V}(b)) \cos(2\pi tf)} \\ B_{im} = -\overline{(V(b) - \bar{V}(b)) \sin(2\pi tf)} \end{cases} \quad (5)$$

where:

A_{re}, B_{re} – real parts of signals in points a and b ,
 A_{im}, B_{im} – imaginary parts of signals in points a and b ,
 f – input signal frequency,
 t – time,
 $\bar{V}(a), \bar{V}(b)$ – voltage in point a and b .

The last two formulas determine amplitude and phase characteristics. In order to define the final equations, the authors defined module (6) and argument – phase shift (7) of the spectral transfer function as:

$$|G(\omega)| = \frac{A(\omega)}{B(\omega)} \quad (6)$$

$$\varphi(\omega) = \arg G(j\omega) = f_A(\omega) - f_B(\omega) \quad (7)$$

where:

$A(\omega), B(\omega)$ – voltages in points a and b in function of pulsation ω ,
 $f_A(\omega), f_B(\omega)$ – phase shift of signals in points a and b in function of pulsation ω .

The transfer function can be also defined by the equation:

$$G(j\omega) = G_{re}(\omega) + jG_{im}(\omega) \quad (8)$$

where:

$$\begin{cases} G_{re}(\omega) = \text{Re}(G(j\omega)) \\ G_{im}(\omega) = \text{Im}(G(j\omega)) \end{cases} \quad (9)$$

The module of transfer function can be also defined as:

$$|G(j\omega)| = \sqrt{G_{re}^2(\omega) + G_{im}^2(\omega)} \quad (10)$$

The following equations are the final definition for amplitude and phase characteristics:

$$\begin{cases} |G(\omega)| = 20 \log |G(j\omega)| \\ \varphi(\omega) = \arctg \frac{G_{im}(\omega)}{G_{re}(\omega)} \end{cases} \quad (11)$$

The LTspice formulas using the equations from (7) are presented below:

$$\begin{cases} \text{.measure GainMag param } 20 \cdot \log_{10}(\text{hypot}(A_{re}, A_{im}) / \text{hypot}(B_{re}, B_{im})) \\ \text{.measure GainPhi param mod}(\text{atan2}(A_{im}, A_{re}) - \text{atan2}(B_{im}, B_{re}) + 180, 360) - 180 \end{cases} \quad (12)$$

In the case of amplitude characteristic (GainMag), the authors used the hypot function to define the magnitude of A and B vectors. The final result is given in [dB].

Based on (7)–(11), the authors determined the phase characteristics (GainPhi). They also used the modulo function (mod) to move all values to one period (remainder from division by 360). What is more, in order to obtain the positive value in mod function, one should add 180 degrees (subtracting it later to obtain proper conditions), thus arriving at the final results.

2. Simulation results

Simulations were carried out for three different circuits: an RLC resonant circuit, an active filter, and the power stage of a Buck-Converter. Determining the open loop gain from a closed loop switch mode power supply is best accomplished using Middlebrook's method.

2.1. Resonant circuit

The first example shows the results for the simple linear RLC circuit from Fig. 1 – capacitor voltage in relation to input voltage. In order to compare the classic. AC analysis with Middlebrook's method, the authors made a frequency analysis using both methods. The results for 1000 measurement points per decade for. AC analysis and Middlebrook's method are presented in Fig. 2. and Fig. 3.

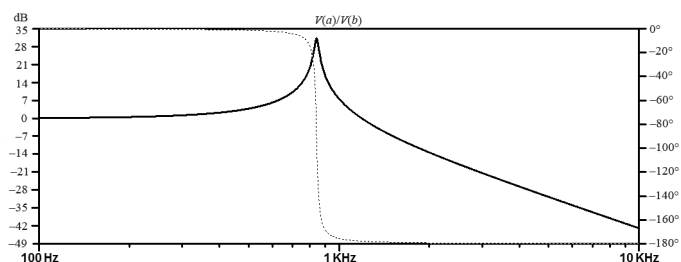

Fig. 2. Resonant circuit – classic .AC analysis

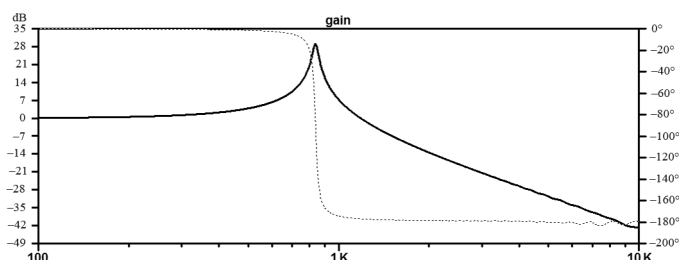

Fig. 3. Resonant circuit – Middlebrook's method

As can be seen in Fig. 2 and Fig. 3, in respect of the simple linear resonant circuit, the results from the classic .AC analysis and from Middlebrook's method are the same. The resonant frequency from calculations is ca. 842.33 Hz. The results from Middlebrook's method depend on the number of frequency changes. This simple exercise was designed to verify whether the mathematical equations and instructions in LTSpice are correct and allow for the determination of the frequency characteristics of the circuit using Middlebrook's method.

2.2. Active filter

The second analysis was carried out for the active low pass filter presented in Fig. 4.

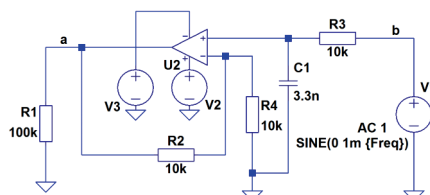

Fig. 4. Low-pass active filter

The frequency characteristics for the above circuit, determined using Middlebrook's method, are presented in Fig. 5.

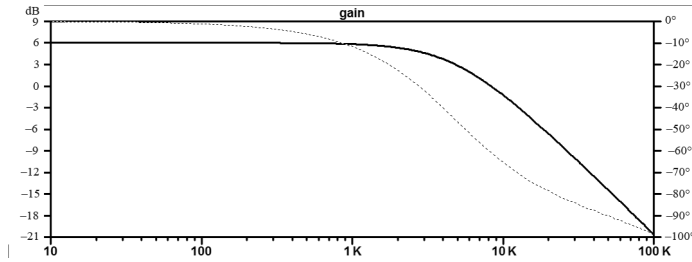

Fig. 5. Low-pass active filter – Middlebrook’s method

The frequency characteristics of the filter are same as the ones obtained from classic .AC analysis. These two simple examples demonstrate that the results obtained using Middlebrook’s method are the same as the ones produced in .AC analysis. However, the time taken to make the calculations with the classic .AC analysis is significantly shorter than the time taken by the other method. This is due to the fact that in order to obtain frequency characteristics of a circuit using Middlebrook’s method, it is necessary to carry out ca. 100. TRAN analyses, which is far more time-consuming.

2.3. Buck converter with a correction circuit

In this part, the authors analyzed a step-down converter with a correction circuit to show Middlebrook’s method for nonlinear circuits (with a transistor switch and a PWM regulator). The authors carried out the following simulations for three cases of additional voltage source locations and amplitudes. All the simulations were done for 100 measurement points per decade. The element values in correction circuit were selected to obtain a visible resonant frequency. In the first case (Fig. 6), the additional voltage signal amplitude was defined as 1 mV (because of significant damping of the amplifier) and the step frequency from 10 Hz to 5 kHz.

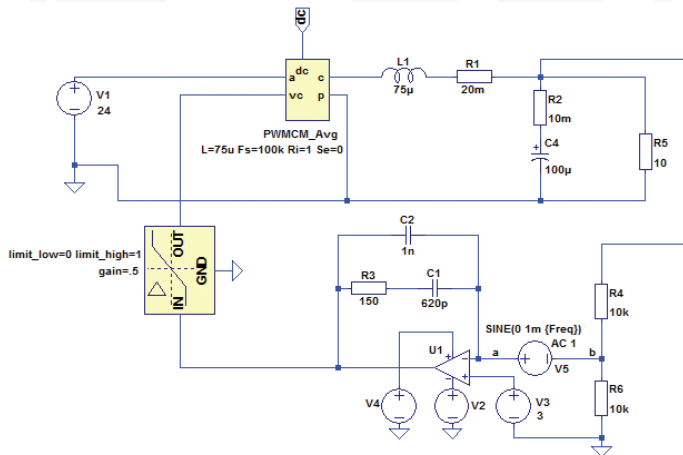

Fig. 6. Step-down converter with a correction circuit – case I

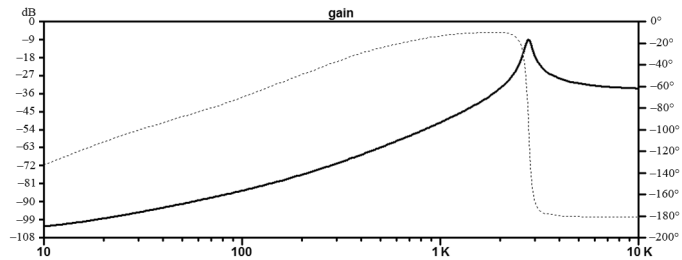

Fig. 7. Frequency analysis result for Step-Down Converter – Middlebrook's method

The analysis of the case shown in Fig. 6 shows the effect of element values from the correction circuit on the frequency characteristics.

In the second case of a buck converter, the voltage signal amplitude was defined as 100 mV in order to show the analysis for changing load current.

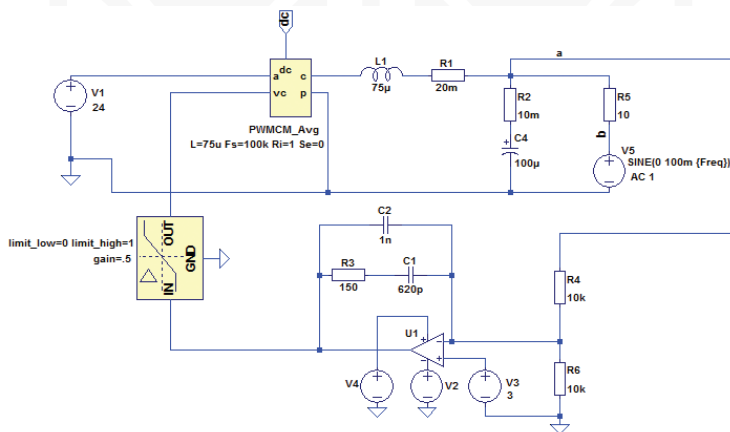

Fig. 8. Step-down converter with a correction circuit – case II

Fig. 9 presents the frequency analysis for the circuit from Fig. 8.

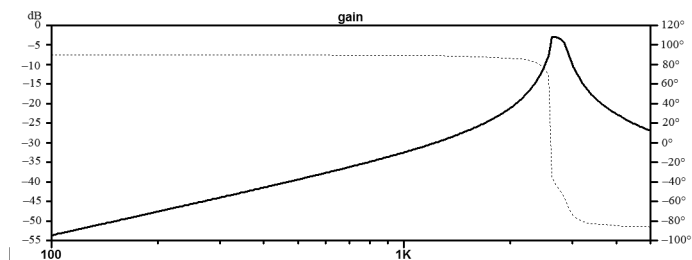

Fig. 9. Frequency analysis result for step-down converter – Middlebrook's method

In order to verify Middlebrook’s method, the authors carried out a dozen or so individual. TRAN analyses (the frequency of V5 ranged from 100 Hz to 5 kHz) and manually determined the frequency characteristics of the circuit, which is shown in Fig. 10.

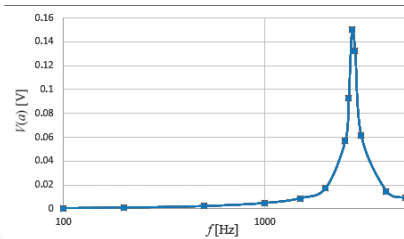

Fig. 10. Output voltage (AC component) for frequency step changes, $f_r = 2.65$ kHz

Comparing the results from Fig. 9 and Fig. 10, one can see that the resonant frequency 2.65 kHz is identical. This confirms the correctness of Middlebrook’s results. Low frequencies of load current have only slight impact output voltage. The oscillations of output voltage appear around the resonant frequency.

The circuit from Fig. 11 has an additional point defined (b1) to obtain the changes of additional voltage signal (V5). The signal amplitude was 10 V to show the effect of the input voltage changes on the output voltage.

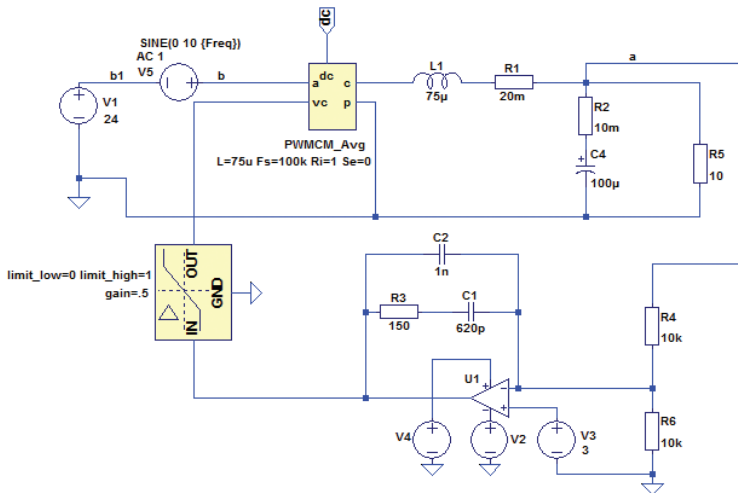

Fig. 11. Step-down converter with a correction circuit – case III

In Fig. 12, one can see a small effect of the input voltage AC component on output voltage. The pulsation of output voltage occurs for resonant frequency about 150 Hz (the damping about 30 dB).

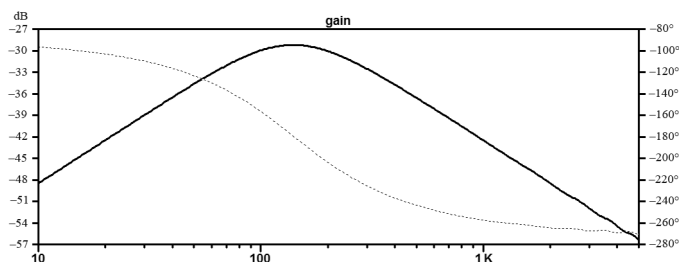

Fig. 12. Frequency analysis result for a step-down converter – Middlebrook's method

2.4. Power stage of a buck converter

In order to show incorrect results from Middlebrook's method, the authors carried out a simulation for the power stage of a buck converter (Fig. 13) with an additional signal amplitude of 1 mV.

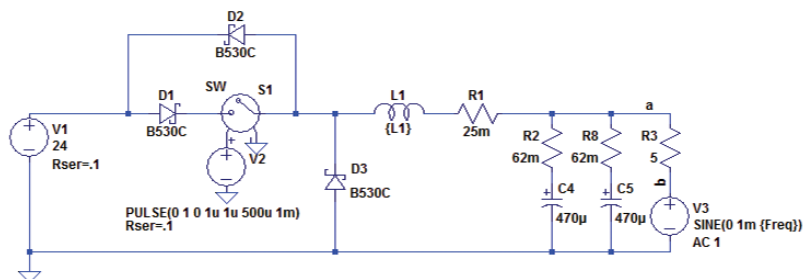

Fig. 13. Frequency analysis result for a step-down converter – Middlebrook's method

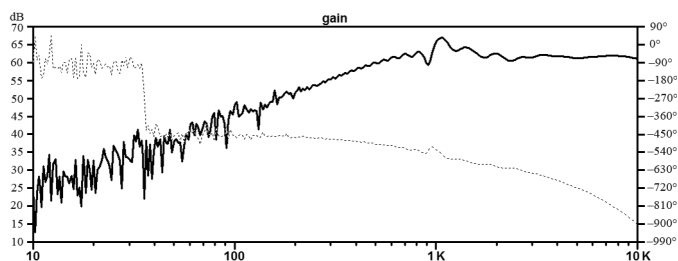

Fig. 14. Frequency analysis result for a step-down converter – Middlebrook's method

The results from Fig. 14 show that the wrong selection of voltage amplitude of the additional source in the Middlebrook's method gives the wrong results: phase shift up to 90° and inaccurate amplitude characteristic.

3. Advantages and disadvantages of Middlebrook's method

Middlebrook's method has both advantages and disadvantages, depending on the analyzed circuit. In this method, it is important to choose enough measurement points to obtain correct results (sufficient number of frequency steps). If the number of points is too small, the frequency characteristics are imprecise. Incorrect results can also be produced when a sine signal in a measurement point (output point) is distorted. This can result from defining an incorrect input signal amplitude. The value of an additional source amplitude varies in the case of different circuits and should be determined separately for each circuit. Another important parameter is the range of input signal frequencies. For example, in switched power supply circuits, power transistor control frequency is found. In order to ensure that frequency analysis results in the method presented are as accurate as possible, the maximum input signal frequency has to be much lower than the power transistor control frequency. An important disadvantage is the simulation time. Because of many iterations, the analysis lasts much longer than in the case of the classic .AC analysis (the duration of Middlebrook's method analysis is tens of seconds, whereas the classic method only takes tens of *milliseconds* to complete – depending on circuit complexity). That is why it is not recommended to use Middlebrook's method for simple, linear circuits.

In order to determine frequency characteristics, it is necessary to carry out .TRAN time analysis many times. The time taken to do that should be added to the time needed by the user to select (find) the right input signal amplitude. Based on the numerous simulation tests on the step-down converter, the authors conclude that, in order to obtain reliable results using Middlebrook's method, simulations have to be performed many times.

The main advantage becomes apparent when comparing Middlebrook's method with classic .AC analysis is that the former involves nonlinear element characteristics (classic .AC analyses linearize circuits in an unknown way, which gives unreal results). It is important to bear this mind in the case of power converters with PWM regulators and transistor switches in their power stage. The results from Middlebrook's method are more real. The frequency characteristics of a circuit are mainly determined in order to verify the gain of a circuit versus frequency, in other words, how the amplitude of an input signal changes relative to the input signal frequency. Middlebrook's method and the capabilities of LTspice allow the user to verify the effect of changes in an input parameter as a function of frequency (this can be e.g. current, voltage, a parameter of an element) on a selected output parameter from the circuit (e.g. voltage or current). This allows engineers to verify the behavior of power circuits, such as DC/DC converters within a given frequency range.

4. Summary

This paper is a development of the considerations made in [6]. The authors presented three types of circuits: a resonant circuit, a low-pass filter and a buck converter. As shown in Fig. 2 and 3, in respect of simple circuits, Middlebrook's method produces the same results as classic .AC analysis. In this case, it is more advantageous to use .AC analysis because it is much faster.

For more complex circuits, such as buck converters (Fig. 6, Fig. 8 and Fig. 11), which contain a nonlinear element, it is recommended to use Middlebrook's method. This technique is precise because it involves nonlinear characteristics of components, but it is important to define the appropriate number of frequency changes.

Middlebrook's method can be very useful while designing the power stages of DC/DC or AC/DC converters, analyzing the effect of elements from correction circuits on output voltage, and testing stability of more complex circuits.

References

- [1] Alonso G., *Basic steps in generating a bode plot of SMPS*, <http://www.linear.com/solutions/4673> (access: 01.07.2016).
- [2] Choi H., *Practical Feedback Loop Design Considerations for Switched Mode Power Supplies*, Fairchild Semiconductor Power Seminar, 2010, 1–14.
- [3] Engelhardt M., *Extracting Switch Mode Power Supply Loop Gain in Simulation and Why You Usually Don't Need To*, <http://www.linear.com/solutions/4672> (access: 01.07.2016).
- [4] Middlebrook R.D., *Measurement of loop gain in feedback systems*, *Int. J. Electronics*, vol. 38, 1975, 485–512.
- [5] Paperno E., *Simulating Return Ratio in Linear Feedback Networks by Middlebrook's Method*, 2012 http://www.ee.bgu.ac.il/~paperno/Lecture_notes_2012_2013/%20%28not%20for%20exam%29%20Additional%20reading%20on%20feedback/Simulating%20return%20ratio.pdf (access: 01.07.2016).
- [6] Prąglowska-Ryłko N., Mysiński W., *Comparison of frequency analysis methods for correction circuits in Step-Down Converters*, *Poznan University of Technology Academic Journals*, 2016, 323–332.
- [7] Zhang Henry J., *Modeling and Loop Compensation Design of Switching Mode Power Supplies*, Linear Technology, Application Note 149, 2014.

