

MICHAŁ MUSIAŁ*

MODELS FOR CALCULATING DYNAMIC CHARACTERISTICS OF FRAME FOUNDATION UNDER THE TURBINE SET

MODELE DO OBLICZANIA CHARAKTERYSTYK DYNAMICZNYCH FUNDAMENTU RAMOWEGO POD TURBOZESPÓŁ

Abstract

The article describes dynamic analyses of frame foundation for a turbine set with a capacity of 20 MW. In the introduction, the author discusses a general method of performing dynamic calculations in building structures. The natural analyses were performed using three methods: a simplified method, a finite element method for the bar structure and the volumetric structure. The course of action was described in detail. The quality of the results was compared. General recommendations for this type of analyses were formulated.

Keywords: frame foundation, turbine set, eigensolution, reinforced concrete

Streszczenie

W artykule opisano analizy dynamiczne fundamentu ramowego pod turbozespół o mocy 20 MW. We wstępie omówiono ogólnie sposób prowadzenia obliczeń dynamicznych w konstrukcjach budowlanych. Analizy własne przeprowadzono trzema metodami: metodą uproszczoną, metodą elementów skończonych dla konstrukcji prętowej i objętościowej. Opisano szczegółowo tok postępowania. Porównano jakość otrzymanych wyników. Sformułowano ogólne zalecenia do tego typu analiz.

Słowa kluczowe: fundament ramowy, turbozespół, zagadnienie własne, żelbet

* Ph.D. Eng. Michał Musiał, Faculty of Civil Engineering, Wrocław University of Technology.

1. Introduction

Dynamic effects are relatively rare problems considered in the design of common civil engineering structures. They depend on the nature of load acting on the structure and its kind. For typical facilities, in case of which a negligible influence of dynamic nature of external effects was demonstrated, additional coefficients increasing the load are used. These coefficients are adopted arbitrarily; on the basis of standards, guidelines, or the experience of the designer. A wind load of typical facilities of common construction industry can serve as an example. The load is treated in calculation as a static one, but increased with an additional coefficient [4, 14, 19]. A similar procedure is used in the case of overhead crane supporting structures [5, 16]. In building engineering, it is possible to indicate the facilities for which the impact of dynamic loads is completely passed over. Such procedure is acceptable, if it does not entail negative effects in terms of the impact on users, safety of the structure and the operation of equipment supported by it.

A special group of structures are those for which a more precise dynamic analysis is needed. These are, among others, facilities with a high susceptibility to wind.

Other examples can be supporting structures of machines, such as block, frame and other foundations (e.g. floor slabs loaded dynamically, stand-alone elevated platforms loaded with machinery, cantilevers fixed to the walls or columns loaded with machines and others). Dynamic analyses can be performed using different methods, depending on the available computational tools, complexity of the issue or other factors. The range of calculations can be reduced to an in-depth analysis of the eigensolution and calculate respective dynamic factors attributed to the considering case [9]. For this purpose, a known dependence to the dynamic factor should be applied, when $f_m < f_e$:

$$v = \frac{1}{\sqrt{\left(1 - \left(\frac{f_m}{f_e}\right)^2\right)^2 + \left(\frac{\Delta}{\pi}\right)^2 \left(\frac{f_m}{f_e}\right)^2}} \quad (1)$$

where:

- f_m – frequency of excitation from machine [Hz, rad/s, cycles/min, etc.],
- f_e – eigenfrequency of the structure [Hz, rad/s, cycles/min, etc.],
- Δ – logarithmic decrement of damping.

In case of transient resonance, when $f_m > f_e$ it must be assumed:

$$v_{\max} = \frac{\pi}{\Delta} \quad (2)$$

The exciting force is then subject to reduction with coefficient $\left(\frac{f_e}{f_m}\right)^2$.

The above calculation method seems to be the most popular in the analyses of engineering structures. Therefore, in the remainder of the article, only this method was described. The calculations at the highest stage of progress, involving the numerical modelling of structure

along with the dynamic loads (variables in time), should also be mentioned. In that case, dynamic analysis should be performed in two steps [7]. First of them is the eigenanalysis. Second is the harmonic forced vibration analysis. However, due to the complexity of this process and the need for large-scale computing systems, such analyses do not seem to be always effective, and they are often impossible.

The identification of foundation parameters is also possible with other methods (e.g. the least square method [17]).

2 The subject of analyses, formulation of problem

The subject of the dynamic analyses described in this article is the frame foundation under the turbine set with a capacity of 20 MW. The structure was erected in the 1960s. So far, it has been a supporting structure under the turbine set with a capacity of 19 MW. The foundation consisted of the bottom plate with dimensions of $18.00 \times 5.80 \times 2.50$ m. 8 columns (in 2 rows of 4) were erected on the plate. They were joined with 2 longitudinal beams and 4 transverse beams. The beams joined each other over the columns and constituted the so-called upper plate. The old turbine set was fixed rigidly to the foundation frame, without vibration isolators. Based on destructive tests, a characteristic strength of the concrete of f_{ck} bottom plate and columns was determined. It was 24.8 and 17.0 MPa, respectively.

As part of the modernisation, the existing base plate was left. Because of the low strength of the concrete of columns and transmission of loads from turbine set in other places, it was decided to erect new columns on the old plate with the upper plate in the form of grate using C30/37 concrete. Technological issues of the modernisation process are described in more detail in [13]. The geometry of a new frame foundation, together with the points of the application of loads, is shown in the figures below (Fig. 1 – axonometric view, Fig. 2 – cross-sections with dimensions in cm).

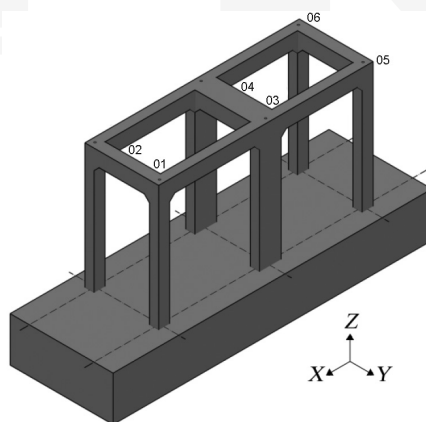

Fig. 1. Axonometric view

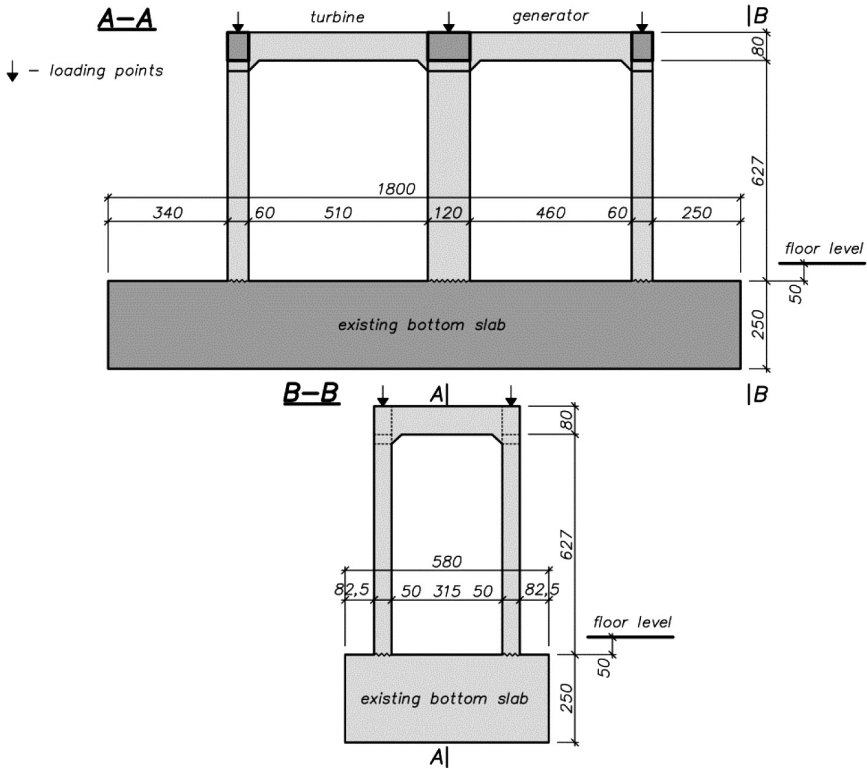

Fig. 2. Longitudinal view and cross-section (dimensions in cm)

In the new system, loads from the turbine set are transmitted to the structure by means of vibration isolators with parameters shown in Table 1.

Table 1

Stiffness of vibration isolators

Parameter	Over the external column	Over the middle column
Vertical stiffness	7720 kN/m	15520 kN/m
Horizontal stiffness	7570 kN/m	15140 kN/m

In calculations of cross-section forces, the following loads were taken into consideration:

- 1) deadweight of reinforced concrete structure,
- 2) deadweight of condenser on the bottom slab, working platforms and installations,
- 3) deadweight of soundproof casing,
- 4) thermal load (even heating of structure with $\Delta t = 30^{\circ}\text{C}$),
- 5) concrete shrinkage (shrinkage deformation $\epsilon_s = 0.15\%$),
- 6) loads from the deadweight of machine,

- 7) loads caused by the normal operation of the machine,
- 8) loads from the moment of short circuit,
- 9) loads caused by the failure of machine.

Loads 6)–9) were provided by the supplier of machine. Exciting forces acting in three directions are given in Table 2. Coordinate system and the numbers of bearings are shown in Fig. 1.

Table 2

Exciting forces provided by the supplier of the machine

Bearing	Load case	F_x [kN]	F_y [kN]	F_z [kN]
01	7)	-0.26	0.04	-2.11
	8)	-0.16	-0.5	-0.78
	9)	1.48	4.34	2.62
02	7)	0.24	0.09	2.18
	8)	-0.31	-0.39	1.32
	9)	2.2	3.45	6.61
03	7)	-1.48	0.67	-1.57
	8)	0.88	-1.78	-4.26
	9)	8.24	14.16	27.67
04	7)	1.49	0.58	1.42
	8)	-0.77	-1.69	4.83
	9)	6.79	13.34	32.6
05	7)	-0.54	-0.69	3.68
	8)	0.39	-1.85	-4.87
	9)	3.70	16.17	47.27
06	7)	0.55	-0.69	-3.60
	8)	-0.25	-1.85	4.33
	9)	4.18	16.20	34.71

Due to the thermal insulation of machine body, the impact of uneven heating of the upper plate was omitted. The design of the condenser also allowed to omit forces caused by its run. Loads were listed according to Polish Standard [15], which directly concerns foundations and supporting structures for machines. In case of the necessity of the Eurocodes application (e.g. on investor demand), requirements and guidelines included in Eurocodes: 0 [3] and

8 [4] could be used. However, these codes deal with the type of the structure described in the paper only partially. Furthermore, the choice of the group of standards (Polish Standards or Eurocodes) is rather the designer's decision.

Generator and turbine speeds were 25 and 100 Hz, respectively. According to the literature [8, 10], a logarithmic decrement of damping 0.4 and the fatigue coefficient of 2 were assumed. The logarithmic decrement of damping mainly depends on the material and the kind of structure. The value assumed in the considered case was taken from engineering practice. The interaction of the structure with the ground was omitted. This was due to considerable dimensions of the bottom plate, a high degree of reinforcement, favourable ground and water conditions and the compacting of the soil by the old turbine set operating for dozens of years. An additional factor was a high rotational speed of the machine, which partially determines the selection of the computational model. Finally, it was a frame rigidly fixed in the bottom plate. The interaction of the structure with the soil can be considered in a detailed way if it is necessary (e.g. [2]).

The key element of the discussions was to determine the eigenfrequency and eigenforms. It was necessary to calculate dynamic coefficients according to (1) and (2) for loads under normal operating conditions. In the remainder of the paper, the course of the dynamic analyses in terms of the eigensolution was presented in detail.

3. Numerical analyses

The eigensolution analyses were performed in three different ways. The first of these was a simplified method proposed in [10]. The second used the finite element method for spatial bar systems with regard to the stiffening of the nodes [18]. In the third variant, the finite element method was applied for the volumetric structure

3.1. Simplified method [10]

In the simplified method, separated transverse frames (in the case analysed – 3 pcs.) are considered. The influence of the stiffness of longitudinal beams is omitted. Due to the approximate nature of calculations, it does not affect the results. Eigenfrequency is calculated from relation:

$$f_e = \frac{1}{2\sqrt{a}} [\text{Hz}] \quad (3)$$

where:

a – a corresponding elastic displacement in the direction considered [m].

In case of vertical vibrations by a vertical displacement in the middle of the span of the spandrel beam is assumed. This displacement is caused by the deadweight of the spandrel beam g_b and the weight of the machine G_m occurring to the flat frame, applied as in the real facility (e.g. to a node or spandrel). In addition, in the corners of the frame, vertical concentrated forces $G_{1/3}$, resulting from the deadweight of the longitudinal beams and the devices placed on them, the weight of the upper part 1/3 of the height of columns and

cantilevers, platforms and devices based in this area on the structure of foundation frame, should be applied.

When considering horizontal vibrations, the a should be assumed as the horizontal displacement of the corner of the separated frame, due to a force corresponding to the vibrating mass is assumed. This mass consists of the following: spandrel beam, machine, loads from the upper part 1/3 of the height of columns (fixed as in the case of vertical vibrations). Vertical displacement a_v and horizontal displacement a_h should be determined according to the diagrams shown in Fig. 3. For this purpose, a conventional static analysis of the separated frame should be performed, or the approximate formulas for the displacement of flat frames should be used.

The results of the calculations using the simplified method for the analysed turbine set are shown in Table 3. To obtain global values for the entire system, the results for 3 flat frames can be averaged. Vertical eigenfrequency can be estimated as 36.7 Hz, and the horizontal one as 3.02 Hz.

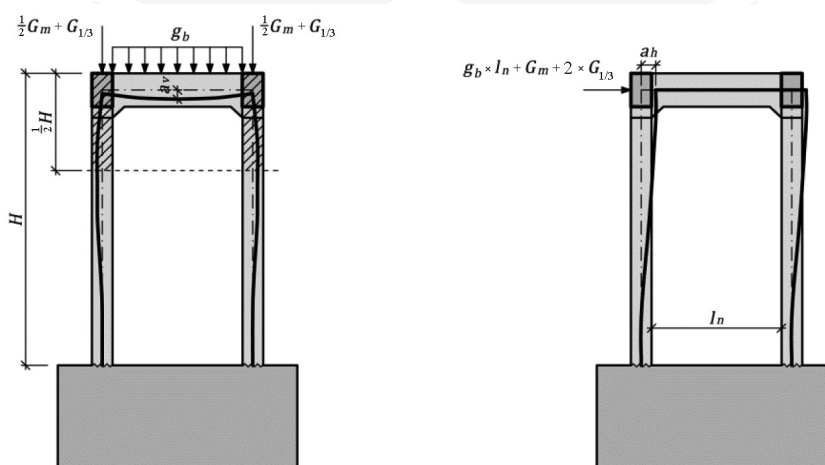

Fig. 3. Diagram for simplified calculations: a) for vertical vibrations, b) for horizontal vibrations

Table 3

The results of calculations using the simplified method

Parameter	External frame (under the turbine)	Middle frame	External frame (under the generator)
Vertical displacement	186.9 μm	186.8 μm	181.7 μm
Vertical eigenfrequency	36.6 Hz	36.6 Hz	37.1 Hz
Horizontal displacement	27.68 mm	27.64 mm	26.76 mm
Horizontal eigenfrequency	3.01 Hz	3.01 Hz	3.06 Hz

3.2 Finite element method – spatial bar structure

The second analysed model was a spatial frame considered as a bar structure. The principle of node stiffening [18] was taken into consideration in the calculations. Sections of stiffening s_i for each bar of the node were calculated from the relationship:

$$s_i = d_i - 0.1h_i - 0.15h_{i,\max} \quad (4)$$

where:

- d_i – width of support,
- h_i – height of the considering bar,
- $h_{i,\max}$ – maximum height of the bar reaching the node without taking into account the considering bar.

Data for the relationship (4) for the exemplary node of the structure should be assumed as in Fig. 4.

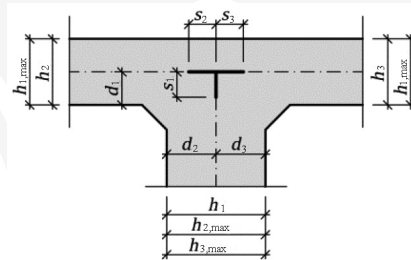

Fig. 4. The node of the structure with rigid sections

In the analysed model, the turbine set was represented by a weightless rigid structure. This was to eliminate the machine itself in calculating eigenfrequencies. To simplify the mass of the turbine set is centred around the shafts of the turbine and generator. However, it is possible to prepare a model of machine in a more advanced way, including the rotor and stator [1]. The machine with the structure was joined with elastic elements with stiffness as in Table 2. Bar stiffness was assumed in accordance with [11, 12]. The calculation model was shown in Fig. 5.

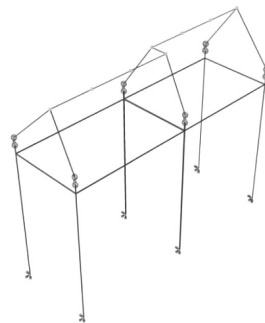



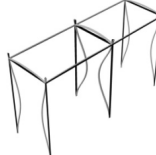

Fig. 5. Model of the bar structure

In Table 4, calculation results are summarised. These are the first 3 horizontal (H) eigenforms (translational – transverse, translational – longitudinal, torsional) and the first vertical (V) eigenform together with the corresponding frequencies (designation – m2.0). The drawings of the eigenforms do not show the machine, only the “zero” state and forms of reinforced concrete frame. In addition, for comparison purposes the results of calculations performed for the model, which did not take into account stiff nodes (designation – m2.1) and the model, in which vibration isolators were replaced by classic joints that block translation displacements are listed (designation – m2.2).

Table 4

Calculation results for the bar model

Number	1H	2H	3H	1V
Eigenform				
Value ^{m2.0}	2.355 Hz	3.267 Hz	4.226 Hz	37.43 Hz
Value ^{m2.1}	2.302 Hz	3.207 Hz	4.065 Hz	35.87 Hz
Value ^{m2.2}	3.565 Hz	5.536 Hz	5.173 Hz	34.86 Hz

On the basis of the results for the bar model, it was found that the omission of the principle of the node stiffening can be considered as acceptable. Differences in the results between models 2.0 and 2.1 are negligible and amount to approx. 2–4%. They increase with the increasing eigenfrequency.

The comparison of models 2.0 and 2.2 showed more significant quantitative differences in eigenfrequencies. Also, a qualitative difference should be taken into account. In model 2.2, the eigenfrequency corresponding to translational – longitudinal form is higher than the eigenfrequency corresponding to the torsional form. Furthermore, the difference between them is much smaller than in models 2.0 and 2.1. Pursuant to these observations, model 2.2 must be rejected. Simplification in the form of the elimination of vibration isolators should therefore be considered unacceptable.

3.3 Finite element method – spatial volumetric structure

The final model under consideration was the volumetric structure (Fig. 6). The machine and its connection to the reinforced concrete frame were modelled similarly as in the case of the bar structure.

The results for the first 4 eigenfrequencies are summarised in Table 5. Eigenforms in accordance with the bar model (Table 3) were obtained. Therefore, only the horizontal – torsional form was attached as an example (Fig. 7).



Fig. 6. Model of the volumetric structure

Table 5

Calculation results for the volumetric model

Number	1H	2H	3H	1V
Value	2.357 Hz	3.259 Hz	4.284 Hz	37.84 Hz



Fig. 7. Torsional form in the volumetric model

4 Discussion of the results, summary

Calculation results for the three models are shown in Table 6. The results for the simplified model (designation – m1), bar model (designation – m2) and volumetric model (designation – m3) are shown. The differences between the results for models 2 and 3 are provided.

Table 6

Summary of calculation results

Number	1H	2H	3H	1V
Value ^{m1)}	3.02 Hz			36.7 Hz
Value ^{m2)}	2.355 Hz	3.267 Hz	4.226 Hz	37.43 Hz
Value ^{m3)}	2.357 Hz	3.259 Hz	4.284 Hz	37.84 Hz
$\Delta m2-m3$	<0.10%	0.25%	1.35%	1.08%

For the simplified model, one horizontal eigenfrequency was obtained. It is difficult to state which horizontal eigenform it is associated with. It can be assumed that in the analysed issue, it corresponds to the mean value of the translational–transverse and torsional form of model 2 or 3. It does not refer to the form with a dominant longitudinal movement. In the simplified model, longitudinal deformability is not considered.

The differences between the results for models 2 and 3 are insignificant, and from the engineering point of view, negligible. In the extreme case, the difference does not exceed 1.5%. Minor differences speak in favour of the bar model. Numeric implementation of such a structure is much simpler than the volumetric structure. Moreover, not all calculation programs allow the modelling of volumetric facilities.

The results of the simplified method are recommended to be used to verify the accuracy of the obtained results for more complex models. This method should be considered particularly useful in the days of such a dynamic development of computing systems. It will facilitate a critical evaluation of the results of complex numerical analyses.

The values shown in Table 5 allowed for determination of the dynamic coefficients according to (1), (2) for loads from the machine. This enabled the calculation of the internal forces and amplitudes by way of conventional static analyses.

References

- [1] Bhatia K.G., *Foundations for Industrial Machines and Earthquake Effects*, ISET Journal of Earthquake Technology, Paper No. 495, Vol. 45, No. 1–2, March–June, 2008, 13–29.
- [2] Dhait V.B., Parbat D.K., Ambade B.R., *Geotechnical Aspects In Modelling Framed Type Foundation For 210 MW Turbo Generator Using Computer Software*, International Journal of Modern Trends in Engineering and Research, Vol. 02, Issue 02, February, 2015, 127–132.
- [3] EN 1990: Eurocode: Basis of structural design.
- [4] EN 1991-1-4: Eurocode 1: Actions on structures – Part 1–4: General actions – Wind actions.
- [5] EN 1991-3: Eurocode 1: Actions on structures – Part 3: Actions induced by cranes and machinery.

- [6] EN 1998-1: Design of structures for earthquake resistance – Part 1: General rules seismic actions and rules for buildings.
- [7] Jayarajan P., Kouzer K.M., *Dynamic Analysis of Turbo-generator Machine Foundations*, Journal of Civil Engineering and Environmental Technology, Vol. 1, No. 4, August, 2014, 30–35.
- [8] Kisiel I., *Dynamics of foundations for the machines (in Polish)*, PWN, Warszawa 1957.
- [9] Langer J., *Dynamics of structure (in Polish)*, Publishing House of Wrocław University of Technology, Wrocław 1980.
- [10] Lipiński J., *Foundations for the machines (in Polish)*, Arkady, Warszawa 1985.
- [11] Musiał M., *Static and dynamic stiffness of reinforced concrete beams*, Archives of Civil and Mechanical Engineering, Vol. 12(2), 2012, 186–191.
- [12] Musiał M., *Young's modulus test in two directions on the basis of eigenfrequencies in concrete beams*, Technical Transactions, 3–B/2015, 133–142.
- [13] Musiał M., Kamiński M., Grosel J., *Modernization of reinforced concrete frame foundation for turbine set (in Polish)*, Materiały Budowlane, 9/2015, 78–79.
- [14] PN-77/B-2011: Loads in static calculations – Wind loads (in Polish).
- [15] PN-80/B-03040: Foundations and supporting structures for machines – Calculations and design (in Polish).
- [16] PN-86/B-02005: Actions on building structures – Actions of hoisting devices (in Polish).
- [17] Smart M., Friswell M.I., Lees A.W., Prells U., *Estimating turbogenerator foundation parameters*, Proceedings of the Institution of Mechanical Engineers, Vol. 212, Part C, 1998, 653–665.
- [18] Starosolski W., *Reinforced concrete structures according to PN-B-03264:2002 and Eurocode 2 – Vol. III (in Polish)*, PWN, Warszawa 2009.
- [19] Żurański J., *Wind loads on buildings and structures (in Polish)*, Library of Inżynieria i Budownictwo, Warszawa 1969.