

TADEUSZ GLINKA*, ARTUR POLAK*, ADAM DECNER*, ANDRZEJ SIKORA**

EQUIVALENT CIRCUITS USED IN THE DIAGNOSTICS OF INSULATION IN POWER TRANSFORMERS

SCHEMATY ZASTĘPCZE WYKORZYSTYWANE W DIAGNOSTYCE IZOLACJI TRANSFORMATORÓW ENERGETYCZNYCH

Abstract

An equivalent circuit of the insulation system in power transformers comes in many forms. In tests for the dielectric loss tangent ($\text{tg}\delta$) of the main insulation, the equivalent circuit has been simplified to two-terminal RC series connected or parallel connected circuits. For direct current tests of groundwall insulation modelling, two two-terminals circuits are required – one for charging and shorting, the other for the voltage recovering after shorting. The model turn-to-turn insulation may also be presented by two-terminal circuits. The parameters of the two-terminal circuit can be determined by direct current. The tested winding is energized by DC voltage, the current is interrupted and the voltage waveform on the terminals of the winding is recorded. The parameters of turn-to-turn insulation (equivalent circuit parameters) are calculated from the voltage waveform and they can be used for diagnostic purposes.

Keywords: power transformer, main insulation, turn-to-turn insulation, equivalent circuit

Streszczenie

Schemat zastępczy układu izolacyjnego transformatorów energetycznych ma wiele postaci. W badaniach stratności $\text{tg}\delta$ izolacji głównej schemat zastępczy upraszcza się zwykle do dwójników RC , połączonych równolegle bądź szeregowo. W badaniach izolacji głównej napięciem stałym odwzorowywanie układu izolacyjnego wymaga już dwóch dwójników: jednego dla ładowania i zwarcia, a drugiego dla napięcia powrotnego po krótkotrwałym zwarcu. Izolację międzyzwojową można także odwzorowywać dwójnikiem. Parametry tego dwójnika można wyznaczać prądem stałym. Uzwojenie badane zasila się prądem stałym, a następnie wyłącza się prąd i rejestruje przebieg napięcia na uzwojeniu. Z przebiegu napięcia oblicza się parametry izolacji międzyzwojowej (parametry schematu zastępczego), które można wykorzystać do celów diagnostycznych.

Słowa kluczowe: transformator energetyczny, izolacja główna, izolacja międzyzwojowa, schemat zastępczy

DOI: 10.4467/2353737XCT.15.062.3862

* Prof. D.Sc. Ph.D. Eng. Tadeusz Glinka, Ph.D. Eng. Artur Polak, Ph.D. Eng. Adam Decner, Institute of Electrical Drives and Machines KOMEL, Katowice.

** Ph.D. Eng. Andrzej Sikora, Faculty of Electrical Engineering, Silesian University of Technology, Gliwice.

1. Introduction

Insulation systems comprised of cables, transformers, electrical machines and other electrical devices are multi-layered. Electrical phenomena appearing inside the insulation system are adopted to the equivalent circuits, as shown in the literature. There is no simple equivalent circuit for the insulation system. For example, Г. Вайда [5] gives several different versions of alternative schemes. One of the simplest examples of the insulation is the insulation of a single conductor cable in a metal screen. Even this simple insulation system is characterized by spatial distribution and for this reason, it is represented by the equivalent circuit with distributed parameters. It can be illustrated by a two-terminal circuit with an internal ladder structure which consists of capacitances and resistances connected as shown in Fig. 1.

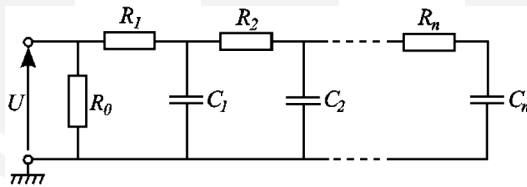

Fig. 1. Equivalent circuit of the insulation system, the example

The transformer insulation system is more complicated, it can be distinguished: turn-to-turn insulation, the insulation between the windings of the upper and lower voltage and the insulation to the core. In Figure 2, an equivalent circuit of the transformer is shown. However, there is no universal equivalent circuit which would be perfect for all phenomena

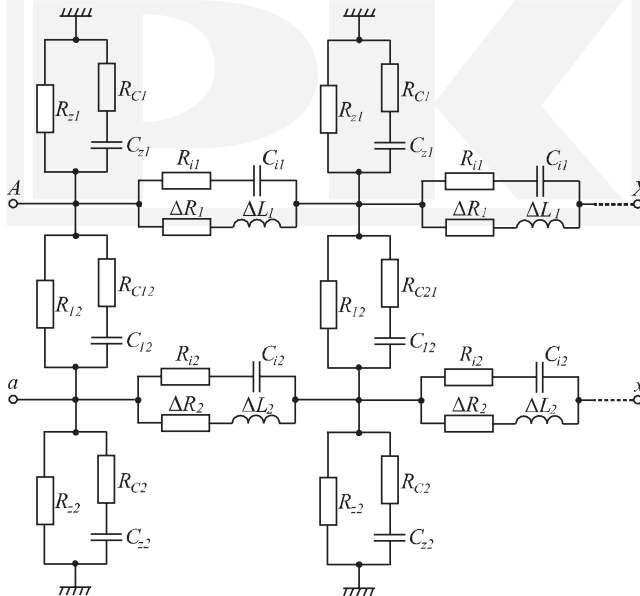

Fig. 2. An equivalent circuit of the transformer insulation system including groundwall and turn-to-turn isolation

appearing in the insulation system, especially during fast transients. The equivalent circuit shown in Fig. 2 is well constructed for an electrical phenomena appearing in the system during the normal operational state of the transformer. This scheme, according to the needs, can be simplified to a two-terminal RC circuit.

Equivalent circuit of the insulation system shown in Fig. 2 consists of two orthogonal circuits – groundwall and turn-to-turn insulation. These circuits can be used during the receipt tests as well as diagnostic tests.

2. Examination of the main transformer insulation

2.1. Testing the insulation with AC voltage

Tests of insulation with AC voltage are made each time the transformer is new or after repair or during the diagnostic. The program of receipt tests of the transformer, in accordance with Standard [3] and the Instruction of Exploitation [4] includes the measure of impedance of insulation system X_x , the measure of dielectric loss factor $\text{tg}\delta$ and the dielectric strength test. The impedance value of the insulation system X_x is used, inter alia, to determine the rated power of the transformer used in the dielectric strength test. During the diagnostic test of the transformer with alternating voltage, the dielectric loss factor $\text{tg}\delta$ is usually measured. In this case, the equivalent circuit is simplified to a two-terminal circuit with clustered parameters C_x , R_x , connected in parallel or in series, as shown in Figs. 3 and 4. These tests are usually carried out on one winding and the other windings and frame are grounded. In this case, the capacitance C_x is calculated from the equivalent circuit (Fig. 2). Similarly, the resistance is also calculated from the equivalent circuit (Fig. 2).

$$\begin{aligned} C_x &= F(R_{Z1}, R_{Z2}, R_{C1}, R_{C2}, R_{12}, R_{C12}, C_{Z1}, C_{Z2}, C_{12}) \\ R_x &= F(R_{Z1}, R_{Z2}, R_{C1}, R_{C2}, R_{12}, R_{C12}, C_{Z1}, C_{Z2}, C_{12}) \end{aligned} \quad (1)$$

The formulas for calculation of the capacitance C_x and the resistance R_x do not include the parameters of turn-to-turn insulation R_{iz} , C_{iz} , so the insulation system is orthogonal.

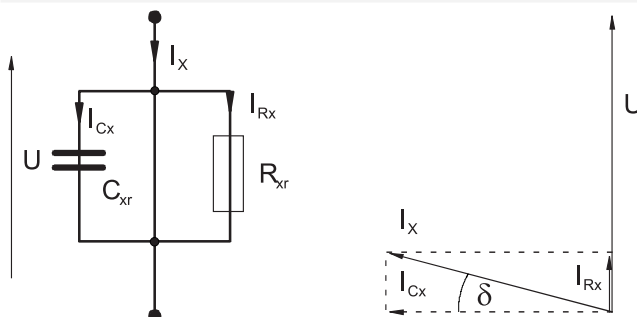

Fig. 3. The parallel equivalent circuit of the insulation system and the definition of angle δ

In parallel equivalent circuits, the dielectric loss factor $\text{tg}\delta$ is calculated as:

$$\operatorname{tg}\delta = \frac{I_{RX}}{I_{CX}} = \frac{1}{\omega R_{xr} C_{xr}} \tag{2}$$

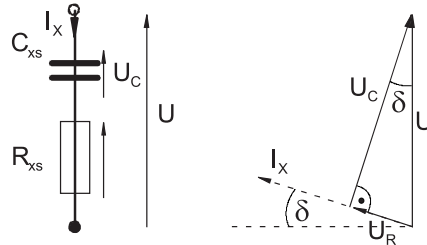

Fig. 4. Serial equivalent circuit of the insulation system and the definition of angle δ

In serial equivalent circuits, the dielectric loss factor $\operatorname{tg}\delta$ is calculated as:

$$\operatorname{tg}\delta = \frac{U_R}{U_C} = \omega C_{xs} R_{xs} \tag{3}$$

2.2. Testing the insulation with DC voltage

The equivalent circuit of the insulation system tested with DC voltage must contain at least three elements: two resistances and capacitance, as shown in Fig. 5.

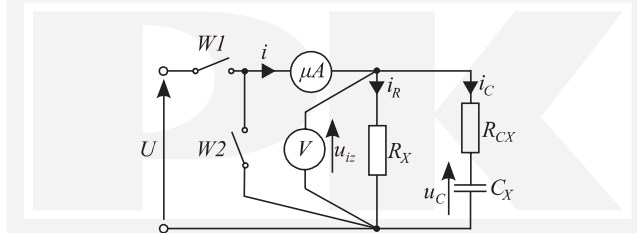

Fig. 5. Interpretation of the charging and discharging of the insulation

The test of insulation with DC voltage consists of switching the voltage U_0 at the time $t = 0$, on uncharged insulation systems and recording the current waveform $i(t)$ and the voltage waveform $u_{ix}(t)$ in the measurement circuit shown in Fig. 5. The transient condition lasts from 60 to 600 s. This time depends on the rated voltage of the winding insulation system and its volume. After determining the current level at time t_1 , the voltage U_0 is switched off (switch $W1$) and the insulation system is short (switch $W2$). The short time of the insulation system lasts until t_2 and is $\Delta t_z = t_2 - t_1$. The time difference Δt_z can range from a few to tens of seconds. It depends on the rated voltage of the winding, the volume of the insulation system and its technical condition. The voltage on the internal capacitance of the insulation system during the short time period is reduced to a value U_{C2} . After opening the insulation system at the time t_2 (switch $W2$), the voltage on the insulating system $u_{ix}(t)$ recovers to the maximum

value U_{\max} , which is achieved at the time t_3 . In the literature, this voltage is also known as the return voltage. Then, the return voltage is slowly reduced to zero. The insulation system discharges itself. The waveforms of the voltage on the insulation system $u_{iz}(t)$ and the current $i(t)$, which are measurable, and the voltage on the capacitance $u_C(t)$, which is not measurable, are presented in Fig. 6. The current i_c is also unmeasurable.

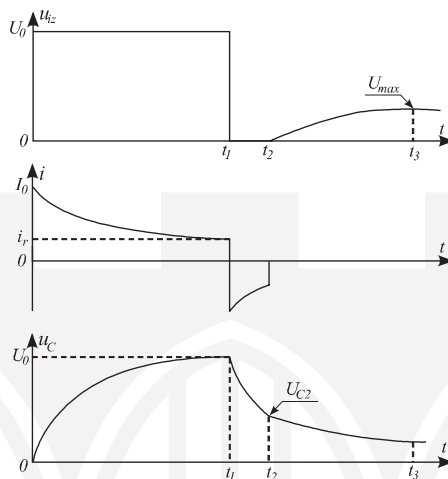

Fig. 6. Waveforms for voltage on insulation system $u_{iz}(t)$, the charging current $i(t)$ and the voltage on the capacitance of the insulation system $u_C(t)$

The voltage waveform $U_{iz}(t)$ and current waveform $i(t)$ in the time interval $0 \leq t < t_1$, are correctly simulated using the equivalent circuit shown in Fig. 5. Based on this circuit, equations describing the charging of the insulation system can be calculated as:

$$\begin{aligned}
 u_{iz}(t) &= U_0 \\
 i(t) &= I_R + (I_0 - I_R)e^{-t/T_1} \\
 u_C(t) &= U_0(1 - e^{-t/T_1}) \\
 T_1 &= R_{CX}C_X
 \end{aligned} \tag{4}$$

From the steady value of the current I_R , the resistance of the insulation system is determined, this is called $R_{60} = R_x$. From the current measurement after 15 and 60 seconds, from the time the voltage was switched on, i.e. $I_{15} = i_{(t=15)}$, $I_{60} = i_{(t=60)}$ the absorbency index R_{60}/R_{15} is calculated.

$$\begin{aligned}
 \frac{i_{(t=15)}}{i_{(t=60)}} &= \frac{I_{15}}{I_{60}} = \frac{R_{60}}{R_{15}} \\
 R_{15} &= \frac{U_0}{I_{15}} \\
 R_{60} &= \frac{U_0}{I_{60}}
 \end{aligned} \tag{5}$$

From the electrotechnics point of view, the resistance R_{15} is calculated from the circuit (Fig. 5), is a complex, but in practice the resistance R_{15} is calculated from the measured values – equation (5).

The voltage waveform $U_{iz}(t)$ and the current waveform $i(t)$ in the time interval $t_1 \leq t < t_2$, are also correctly simulated using the equivalent circuit shown in Fig. 5. Based on this scheme, the equations describing the discharging of the insulation system can be calculated as:

$$\begin{aligned} u_{iz}(t) &= 0 \\ i(t) &= -(I_0 - I_R)e^{-t/T_1} \\ u_C(t) &= -U_0 e^{-t/T_1} \\ T_1 &= R_{CX}C_X \end{aligned} \quad (6)$$

The capacitance C_x of the insulation system is not completely discharged. The capacitance C_x (Fig. 5) has some electric charge Q_C . At the time t_2 , the insulation system is open. After opening switch $W2$, the voltage on the insulation system $u_{iz}(t)$ recovers. The course of the recovery voltage is continuous, from zero to the value U_{max} . The value U_{max} for the insulating system occurs at time t_3 . The equivalent circuit of the insulation system shown in Fig. 5 does not present the course of the recovery voltage in time interval $t_2 \leq t < t_3$. In this case, the course of the recovery voltage can be described by another simple equivalent circuit. The scheme is shown in Fig. 7.

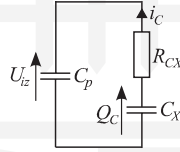

Fig. 7. Equivalent circuit of the insulation system to interpret the recovery voltage

In accordance with the equivalent circuit shown in Fig. 7, the course of the recovery voltage on the insulation system in the interval $t_2 \leq t < t_3$, can be approximated by the equations:

$$\begin{aligned} u_{iz}(t) &= U_{max}(1 - e^{-t/T_2}) \\ i_C(t) &= \frac{C_p U_{max}}{T_2} e^{-t/T_2} \\ T_2 &= R_{CX}(C_X + C_p) \end{aligned} \quad (7)$$

The time interval $t_3 \leq t < \infty$, is a time when the insulation system discharges itself, the voltage $u_{iz}(t)$ decreases from value U_{max} to zero. The course of voltage $u_{iz}(t)$, can be simulated by the equivalent circuit shown in Figs. 7 and also 5. Using the equivalent circuit from Fig. 5, the equations which describe the self-discharging of the insulation system can be calculated as:

$$\begin{aligned} u_{iz}(t) &= U_{max} e^{-t/T_3} \\ T_3 &= (R_X + R_{CX})C_X \end{aligned} \quad (8)$$

All determinations of equations (4) to (7) are shown in Figs. 5–7.

3. Determination of turn-to-turn insulation condition of transformer

The determination of turn-to-turn condition of transformers insulation is an unsolved problem. Most of the failures known to authors, have their beginnings in the turn-to-turn insulation fault, resulting in a shorting. Exposure to surges in the turn-to-turn isolation can come from the supply side and from the consumers of the electricity. There are many surge-generating sources. In the power transformers, which are directly connected to the generator, the sudden turning off of the receiver results in the increase of the generator's voltage.

The winding of the transformer has spread parameters – capacitance, inductance and resistance, for the voltage wave. The voltage wave induces damped electromagnetic oscillations and its distribution and the maximum value changes over time and quickly disappears. However, the most exposing on the damage are turns which are close to the leads. Even if a wave voltage is small, but often repeated, there is a high probability to reduce the dielectric strength of the turn-to-turn insulation of the first turns of the winding and these are the places, which are shorting the most.

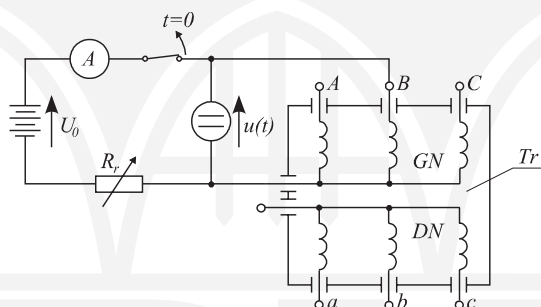

Fig. 8. A measurement diagram for testing the turn-to-turn insulation of the power transformer

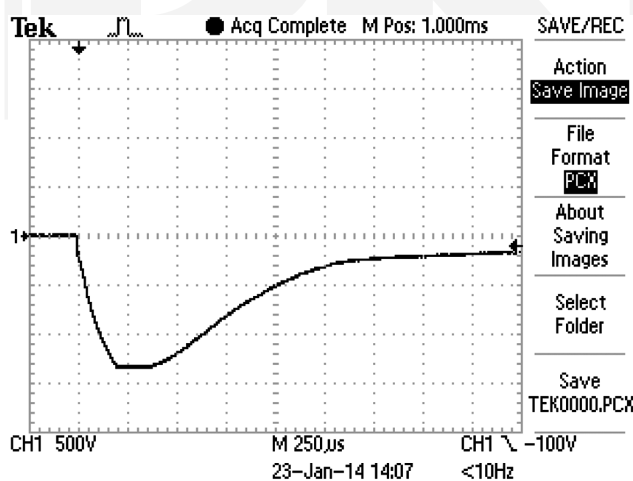

Fig. 9. The voltage waveform $U(t)$ on the terminals of phase B after switching off the current $I = 50$ mA

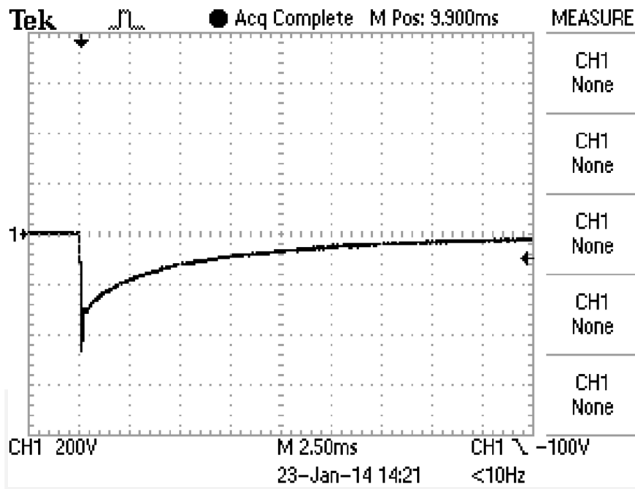

Fig. 10. The voltage waveform $U(t)$ on the terminals of phase B after switching off the current $I = 50$ mA, when an additional turn is short

The capacitance of turn-to-turn insulation and the diagnostic tests of these kinds of insulation can be performed with DC voltage. The measurement diagram is shown in Fig. 8. The phase B of winding GN was fed with a direct current, which had a value of $I = 50$ mA. After the current reached a steady value, the source was turned off, and the voltage waveform $U(t)$ on the terminals of phase B were recorded with an oscilloscope. The voltage $U(t)$ is shown in Figs. 9 and 10.

The maximum value (Fig. 9) $U_{max} = 1340$ V was obtained at the time $t = 0.26$ ms after switching the current off. The time constant of the first part of the wave is $T_1 = 0.177$ ms, the time constant of the second part of the wave is $T_2 = 1.22$ ms.

The maximum value (Fig. 10) $U_{max} = 464$ V was obtained at the time $t = 0.06$ ms after switching current off. The time constant of the first part of the wave is $T_1 = 0.043$ ms, the time constant of the second part of the wave is $T_2 = 4.05$ ms.

The voltage waveforms shown in Figs. 9 and 10 grows from zero to the value U_{max} , and then decreases to zero. These waveforms are determined by the parameters of winding resistance R and inductance L and turn-to-turn insulation parameters capacitance C_{iz} and resistance of insulation R_{iz} (Fig. 2). Voltage rises from zero to value U_{max} during the time interval $0 < t \leq \Delta t$. For this interval, the equivalent circuit shown in Fig. 11 can be assigned.

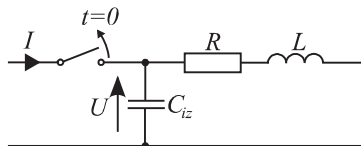

Fig. 11. Equivalent circuit corresponding to conduct the voltage across the winding in the time interval $0 < t \leq \Delta t$

The rise of the voltage waveform can be approximated by the exponential function:

$$U(t) = U_{\max} (1 - e^{-t/T_1}) \quad (9)$$

$$T_1 = \frac{1}{U_{\max}} \int_0^{\infty} [U_{\max} - U(t)] dt$$

The capacitance of turn-to-turn insulation in transformer insulation system can be determined with the energy contained in the inductance L and transferred to the capacitor C_{iz} :

$$0.5LI^2 = 0.5C_{iz}U_{\max}^2 \quad (10)$$

The capacitance C_{iz} is a little bit higher than the real one, because in equation (10), it was assumed that all energy of the inductance L is transferred to capacitance C_{iz} and does not include energy dissipation on resistance R at the time Δt .

For the time interval $\Delta t < t < \infty$, the equivalent circuit corresponding to reduce the voltage to zero, is shown in Fig. 12.

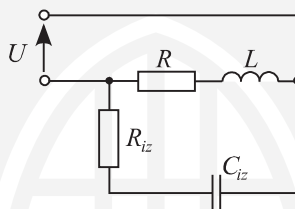

Fig. 12. Equivalent circuit corresponding to the voltage waveform in the time interval $\Delta t < t < \infty$

The decrease of the voltage value to zero, for the time $t > \Delta t$ can be approximated by an exponential function. The time constant T_2 of the exponential function is calculated from the area under the waveform of the voltage $U(t)$, then the resistance of insulation R_{iz} is calculated:

$$U(t) = U_{\max} e^{-t/T_2}$$

$$T_2 = \frac{1}{U_{\max}} \int_{\Delta t}^{\infty} U(t) dt \quad (11)$$

$$R_{iz} = \frac{T_2}{C_{iz}}$$

Table 1

Summary of turn-to-turn insulation parameters

Figure	L	I	U_{\max}	U_{\max} / I	T_1	T_2	C_{iz}	R_{iz}
	H	mA	V	kV/A	ms	ms	nF	kΩ
11	18.00	50	1340	26.80	0.177	1.22	25.0	49
12	0.11	50	464	9.28	0.043	4.05	1.3	—
13	14.00	50	1180	23.60	0.246	1.06	25.0	42

The parameters of turn-to-turn insulation system: capacitance C_{iz} and resistance R_{iz} , were calculated from the waveforms of voltage $U(t)$ (Figs. 9 and 10) and shown in Table 1. As is presented in Table 1, voltage U_{\max} or (U_{\max} / I) time constants T_1, T_2 , capacitance C_{iz} can be used for diagnostic purposes.

4. Conclusions

Power transformer insulation system include the groundwall and turn-to-turn insulation. The electrical parameters of the insulation system are distributed. Electric equivalent circuits of this type of insulation systems may be approximated with two-terminal circuits with an internal ladder structure (Fig. 2). Simplified two-terminal circuits are used in practice during the diagnostic tests of insulation system. Those simplified circuits are built with clustered RC parameters. The structure of this scheme is chosen to correctly simulate the real waveforms of the current and voltage during the diagnostic tests of the insulation system. Diagnostic tests of the groundwall insulation of the power transformers are well developed [1, 2]. This article shows only the dielectric loss factor $\text{tg}\delta$ and recovery voltage, as they have a direct relationship with the equivalent circuit of the insulation system. The article does not discuss the issue of partial discharges and oil testing.

A new proposition, in relation to those known from literature, is a diagnostic test of turn-to-turn insulation. It is proposed that for diagnostic purposes, the voltage waveform on the terminals of winding after switching off the current was used. During the switching off of the current, the voltage induced in each coil is identical. Such tests may be recommended in the receipt tests of the transformer, as an attempt to voltage surges. The short-circuit inside the insulation system affects the value of the inductance as well as the capacitance and resistance of the turn-to-turn insulation. Voltage waveforms $U(t)$ and the results summarized in Table 1 show that it is possible to perform such tests as receipt tests of the new or repaired transformer. These results [voltage U_{\max} or (U_{\max} / I) time constants T_1, T_2 , capacitance C_{iz}], can be used as reference data in the turn-to-turn insulation diagnostic tests performed in subsequent years of transformer operation.

References

- [1] Jezierski E., *Transformatory*, WNT, Warszawa 1975.
- [2] Kazimierski M., Olech W., *Diagnostyka techniczna i monitoring transformatorów*, Wydawnictwo Energopomiar-Elektryka Sp. z o.o., Gliwice 2013.
- [3] Polska norma PN-IEC 76-1/Ak: 1998. *Transformatory. Wymagania ogólne*.
- [4] *Ramowa Instrukcja Eksploatacji Transformatorów*, ZPBE Energopomiar-Elektryka, Gliwice 2012.
- [5] Вайда Г., *Исследования изоляции*, Энергия, Москва 1968.