

ROSTISLAV FAJKOŠ*, RADIM ZIMA**

EVALUATION OF EFFECT OF SURFACE QUALITY OF MACHINED RAIL WAY WHEELS ON FATIGUE STRENGTH

OCENA WPŁYWU JAKOŚCI POWIERZCHNI OBRABIANYCH KÓŁ KOLEJOWYCH NA WYTRZYMAŁOŚĆ ZMĘCZENIOWĄ

Abstract

Railway transport capacities all over the world have been growing, a phenomenon which is accompanied by the requirement to increase axle loads of freight rolling stock. Apart from new wheel designs for higher axle loads, the requirements of their safety and reliability have also been growing, since these wheels are often used in extreme climactic conditions. Cruising speeds of passenger trains been increasing, which likewise brings more stringent requirements concerning the quality and safety of the supplied railway wheels. This paper describes methods of evaluating fatigue strength of railway wheel webs and methods of evaluating the quality of machined railway wheel webs. Results of fatigue tests performed on wheels machined in a standard way are compared with wheels which have been treated by shot peening, a treatment frequently used to increase the fatigue strength of wheel webs of the railway wheelset.

Keywords: railway wheels, shot peening, fatigue strength, surface layer

Streszczenie

Możliwości transportu kolejowego rosną na całym świecie, co powoduje zwiększenie nacisku na osi towarowego taboru kolejowego. Projekty nowych kół oprócz uwzględnienia wyższych nacisków na oś, muszą również uwzględnić rosnące warunki dotyczące bezpieczeństwa i niezawodności, ponieważ takie koła często stosowane są w ekstremalnych warunkach klimatycznych. Także wzrost prędkości przelotowej pociągów niesie za sobą bardziej rygorystyczne wymagania co do bezpieczeństwa jakości dostarczanych kół kolejowych. W pracy opisane zostały metody oceny wytrzymałości zmęczeniowej kołnierzy kół kolejowych oraz metody oceny jakości obrabianych kołnierzy kół. Wyniki przeprowadzonych badań zmęczeniowych kół obrabianych w standardowy sposób porównano z kołami, które traktowane były przez śrutowanie – obróbkę często stosowaną w celu zwiększenia wytrzymałości zmęczeniowej kołnierzy kół kolejowych zestawów kołowych

Słowa kluczowe: koła kolejowe, śrutowanie, wytrzymałość zmęczeniowa, warstwa powierzchniowa

* Ph.D. Ing. Rostislav Fajkoš, BONATRANS GROUP a.s., Czech Republic.

** Ph.D. Ing. Radim Zima, VŠB-Technical University Ostrava, Czech Republic.

1. Material used to produce railway wheels

In Europe, the most frequently used materials in the production of railway wheels are grades ER7 and ER8, defined in standard EN 13262 [1]. These are steels with a resultant perlite-ferrite structure. The wheel rim is usually hardened in the following process: 860°C/5h/water and 520°C/5h/air. The wheel web and wheel hub are left in a normalised state without hardening. Peripheral quenching of the wheel rim by sprinkling followed by tempering induces internal compression stresses in the rim, but in the wheel web only rather moderate tensile stresses. Table 1 shows the chemical compositions of these steels, with maximum content of the various elements in percent by mass.

Table 1

Chemical compositions of steels in percent by mass, recommended for the production of railway wheels in Europe

Steel grade	C [%]	Si [%]	Mn [%]	P [%]	S [%]	Cr [%]	Cu [%]	Mo [%]	Ni [%]	V [%]	Cr+Mo+Ni [%]
ER7	0.52	0.40	0.80	0.020	0.020	0.30	0.30	0.08	0.30	0.06	0.50
ER8	0.56	0.40	0.80	0.020	0.020	0.30	0.30	0.08	0.30	0.06	0.50

Table 2 below shows basic mechanical properties which should be achieved after heat treatment applied by the wheel's manufacturer prior to mechanical machining into the final state for use. Apart from the yield point ReH, ultimate strength Rm and elongation at break A5, maintained in the wheel web must be a difference in ultimate strengths between the rim's hardened zone and the transitional zone between the rim and the wheel web, ΔRm .

Table 2

Mechanical properties of steels used in the production of railway wheels

Steel grade	Wheel rim			Wheel web		KU [J] @ + 20°C		KV [J] @ - 20°C	
	ReH [MPa]	Rm [MPa]	A5 [%]	ΔRm [MPa]	A5 [%]	Median value	Min. Value	Min. Value	Min. Value
ER7	≥ 520	820–940	≥ 14	≥ 110	≥ 16	17	12	10	7
ER8	≥ 540	860–980	≥ 13	≥ 120	≥ 16	17	12	10	5

Other frequently supplied grades are the grades defined in standard AAR M 107 [2]. These are mostly used to produce wheels supplied to American markets, where used are non-alloyed carbon steels of the chemical compositions showed in Table 3, again with a resultant ferrite-perlite structure, designated as Class B or Class C.

Unlike European standards, the AAR standard does not require basic mechanical properties to be measured, apart from HB hardness determined on the side surface of the outer face of the wheel rim, at a distance between 5 and 25 mm from the nominal diameter of the raw wheel.

Table 3

Chemical composition of steels used in railway wheels produced according to AAR standards

Steel grade	C [%]	Si [%]	Mn [%]	P max. [%]	S [%]	Cr max. [%]	Cu max. [%]	Mo max. [%]	Ni max. [%]	V max. [%]	Ti max. [%]	Al max. [%]
Class B	0.57 0.67	0.15 1.00	0.60 0.90	0.030	0.005 0.040	0.25	0.35	0.10	0.25	0.04	0.03	0.06
Class C	0.67 0.77	0.15 1.00	0.60 0.90	0.030	0.005 0.040	0.25	0.35	0.10	0.25	0.04	0.03	0.06

2. Fatigue strength tests of railway wheels

The principle of a fatigue test of railway wheels is checking whether the supplied wheels meet the parameters defined in standard EN 13 262, i.e. whether they can withstand 10 million cycles with the test level of radial stress amplitude set to 240 MPa at the critical point. Schematically, this type of test is carried out at BONATRANS GROUP a.s., preferably on the electro-hydraulic test equipment illustrated in Fig. 1.

According to this standard, the tested wheel should be loaded with such amplitude of axial force (F), cycle asymmetry parameter $R = -1$ and median value of axial force 0 N, which will induce an amplitude of radial stress ± 240 MPa in the tested railway wheel with a machined wheel web, in the critical point. After the fatigue test completion, the wheel web is checked, for instance by using the wet magnetic particle inspection method, for the presence of tangential cracks developed during the fatigue strength test. If both wheels pass the test, the test is regarded as completed. However, internally, for the needs of research and design, in most cases we continue with the test using increased levels, whereby the wheel undergoes 107 cycles at each of the increased levels. The objective of the continuation with the tests until a crack develops in the wheel web, is to determine a sort of a spare strength capacity before the fatigue strength is reached, and thus being able to compare different techniques deployed to strengthen railway wheel webs.

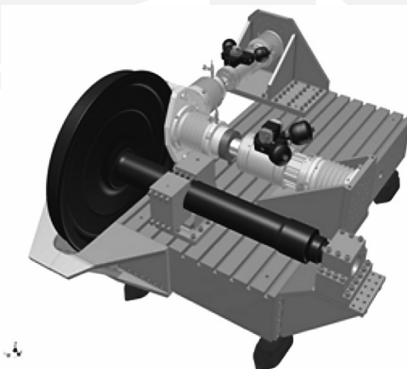

Fig. 1. A 3D model of the electro-hydraulic test equipment used for fatigue strength tests of railway wheels

Sometimes, as described in [3] for example, these tests are continued at each test level by applying only 2 million cycles to one wheel. This allows the level to be gradually increased in smaller steps, making it possible to determine the railway wheel's fatigue strength more accurately, although it must be verified on the other wheel, with the test starting at a lower level, usually reduced by two loading steps below the level at which a crack developed in the first wheel. By gradually loading the part a high number of cycles below the fatigue strength, dislocation strengthening of the material occurs, which increases the fatigue strength of the tested material.

In order to set the test correctly we must, because of the complex state of stresses, glue to the critical zone of the wheel web, identified by using a chain of strain gauges, also a 0°/45°/90° rosette strain gauge. This rosette measures stresses in a radial and tangential directions, which we need to know in order to be able to compute the actual radial test stress.

If we orient the (a) axis of the rosette strain gauge in the radial direction, the (c) axis in the tangential direction and the (b) axis under a 45° angle, the strain gauge apparatus displays, after multiplication by Young's modulus of elasticity E (206 GPa), directly stresses in each of these directions. And then, by applying the extended Hooke's Law, we determine the actual radial stress, using the following formula:

$$\sigma_{\varepsilon 2} = \frac{1}{1-\nu^2} (\sigma_a + \nu \cdot \sigma_c) \quad (1)$$

where:

- $\sigma_{\varepsilon 2}$ – the computed radial stress [MPa],
- ν – Poisson's ratio—for the particular steel wheels and axles $\nu = 0.3$,
- σ_a – stress in radial direction,
- σ_c – stress in tangential direction.

By applying linear regression to the radial stress obtained from formula (1) as a function of the loading force, we can then determine to what value the loading force should be set in the controlling computer, so that the railway wheel is subjected during the fatigue test to a radial stress amplitude equal to ± 240 MPa. If necessary, in order to obtain correct computed radial stresses, a minor adjustment in the setting due dynamic overloading is applied when carrying out a dynamic calibration at the beginning of the fatigues test.

3. Character of surface layers of railway wheels and its impact on fatigue life

Railway wheels are finally mechanically machined by turning their entire surface, either cooled with a cutting emulsion, or in a dry process without cooling. The machining is mostly done using tools with replaceable cemented carbide cutting blades of toughness class P20 and P25, sometimes with TiN and Al₂O₃ surface coating. The blades are mostly of a circular shape and have a 25 mm diameter, and have a suitable chip breaker. In the critical zone on the wheel's web, i.e. at the point of maximum bending moment when the wheel is stressed by imposed forces, the final wheel surface is turned in a two-chip or three-chip process, the so called roughing.

The EN 13262 standard defines for railway wheels the parameters of test stress amplitudes which the tested wheel must withstand for the duration of 10 million cycles.

For wheels supplied with their web machined, the test stress amplitude is ± 240 MPa, while for unmachined wheels supplied with a raw web, the test stress is reduced by 30% to 168 MPa. This difference in fatigue strength of the final product is caused only by the coefficient of surface roughness, η_p . Generally, a smooth or polished surface increases the fatigue strength, whereas surfaces with burrs or which have been only rough-milled, lead to premature initiation of fatigue micro-cracks and ultimately to a lower fatigue strength. This coefficient of surface roughness is mainly the function of arithmetic mean surface roughness, Ra, which is determined exclusively in relation to the machining technology used:

$$\eta_p = \frac{\sigma_{cs}}{\sigma_c} \quad (2)$$

where:

- σ_c – the fatigue strength of smooth samples with polished surface and roughness $Ra = \max. 0.4 \mu\text{m}$ [4],
- σ_{cs} – the actual value of the fatigue strength of the structural part.

We can make a first estimate of the coefficient of surface roughness η_p by again using the diagrams in Fig. 2, used as standard in literature [4–6].

With the steel strength increasing, the coefficient of surface roughness decreases, and therefore the fatigue strength is more sensitive to changes in the surface roughness. With highly polished surfaces, we can achieve as much as a 20% increase in the fatigue strength, although we pay for this increase by higher manufacturing costs of the mechanical part. The largest reduction in the fatigue strength due to surface effects is caused by the corrosive environment which has an impact on fatigue processes by chemical reactions, both in crack initiation and in their propagation [7, 8]. Sometimes, the surface layer parameters and their impact on fatigue properties are influenced by other factors, since besides the parameter of arithmetic mean surface roughness we may include into the character of surface layers and also the impact of the quality of machining.

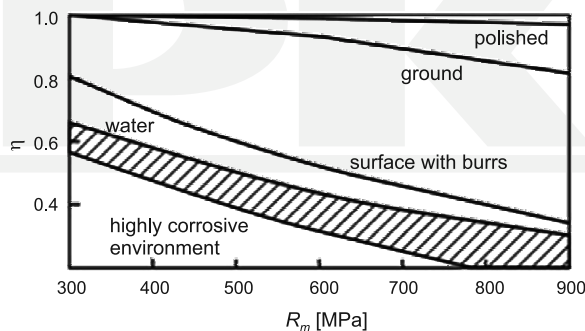

Fig. 2. Coefficient of surface roughness as a function of the strength of carbon steels [4]

Generally, it can be said that railway wheels made from grade ER7 have a sufficient spare strength capacity when testing their fatigue life. Provided the wheel is machined properly, it will withstand 107 cycles even at the amplitude level $\pm 280\text{--}300$ MPa. Wheels made from steel grades with a higher content of C (grades ER8, Class B and other), are basically even

better off because of the higher strength of their normalised structure which develop in wheel web with a higher content of C. However, this at least a 16% spare strength capacity is not enough if the quality of the surface machining is substandard. If, because of tool post vibrations, or because of using a blunt cutting tool, or because of similar technological shortcomings, fissures develop in the cut surface, the fatigue strength of such products decreases rapidly. An example of such a decrease is illustrated in Fig. 3.

It has been demonstrated already in the past [9] that short fatigue cracks up to 1 mm long propagate faster than long cracks. The threshold value of the K factor to stop them is lower than the threshold value of long cracks. If we are evaluating the impact of short cracks merely by their impact on the fatigue strength, we can then conclude that short fatigue cracks up to a certain critical size, usually in the order of tens of microns, do not have any impact on the fatigue strength, while with the presence of cracks exceeding this length, the fatigue strength decreases with the increasing crack length as well as depth. These functions are illustrated in so called Kitagawa diagrams which, however, are not easily obtainable, as they require very demanding experiments to be carried out. For steel 15313.5 of the following mechanical property values: $R_e = 420$ MPa, $R_m = 580$ MPa, $\sigma_c = 250$ MPa, $K_{ath} = 5$ MPa·m^{1/2}, we managed to find in literature the diagram presented in Fig. 3. This is by annealing normalised and tempered steel of the following chemical composition ranges: C: 0.08–0.15; Mn: 0.4–0.8; Si: 0.15–0.4; P and S max 0.035; Cr: 2–2.5; Mo: 0.9–1.1; a Kitagawa diagram for this steel is presented in Fig. 10.

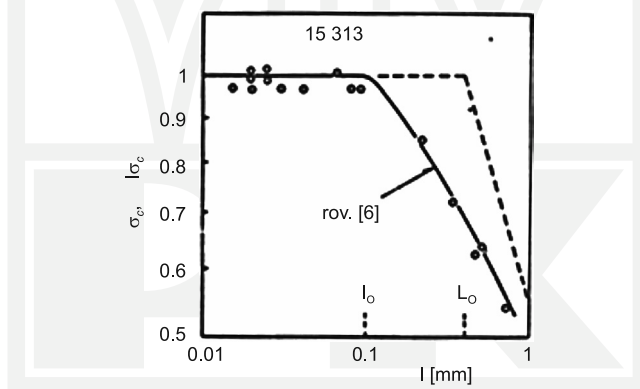

Fig. 3. Kitagawa diagram for steel 15 313.5

As can be seen from Fig. 3, a crack of a size greater than 0.1 mm will have an impact on the fatigue strength of this steel. If a crack is 0.3 mm long, the fatigue strength decreases by as much as 40%. We have observed a similar function with respect to railway wheels which had been machined on older types of vertical lathes, which left machining defects in the wheel web that we internally call fissures. Wheels with such fissures, presented in Fig. 4, did not meet the requirement of the standard on withstanding stress amplitude ± 240 MPa over 107 cycles, as they failed prematurely.

Based on these results and follow-up analyses which revealed no other reason for the wheel's premature failure such as pockets of foreign material inclusions or different

microstructure, etc., another experimental test programme was devised aimed at obtaining final information for evaluating the fatigue strength of wheels whose surface has been machined using different technologies.

To test the real fatigue strength of wheels machined using different technologies, flat bars as illustrated in Fig. 5 were designed. The designed shape of the test bodies allowed us to better capture the character of stresses in the given part of the wheel, and at the same time enabled us to collect such bars from the surface of a wheel with a straight or only gently sloping fixed web. The width of the test bar in the area of the fatigue failure was 24 mm, and the thickness of the sample was 12 mm.

Three variants of final surface treatment of the test samples collected from a wheel web were selected for the experiment. The wheels were machined on CNC two-slide vertical

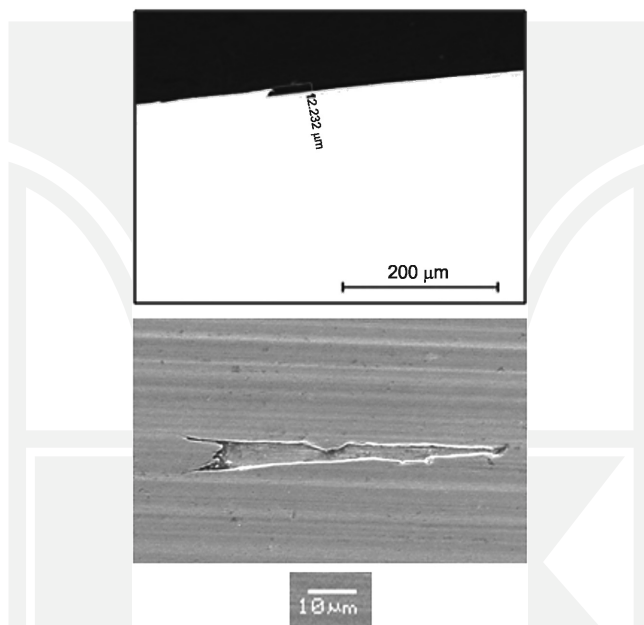

Fig. 4. View of a fissure in a wheel web groove, localised near the critical point, from which a newly developing fatigue crack starts (left), and a metallographic longitudinal section of the fissure (right)



Fig. 5. The shape of a test body for the bending fatigue strength test of different machining technologies

lathes. First, test samples were prepared in such a way that the wheel surface machined in a standard manner would be preserved. Next, samples were prepared from a place 2 mm further towards the wheel web's centre, so that both surfaces of the test sample could be ground. The surface of a third wheel was, before final machining, treated by shot peening, followed by a fine cut taken off on a lathe, and the test samples were again taken in such a way that one side traced the test body's surface.

It was expected that these samples would have an increased fatigue strength, and therefore also the reverse side of the sample and the sides were treated by shot peening to prevent the initiation of a fatigue crack in these areas. Standard material used for the production of railway truck wheels was chosen for preparing these samples, i.e. steel grade R7T and ER7.

Table 4

Surface treatment applied to the samples subjected to cyclic stressing by bending

Test bar identifier – melt, number of test bars	Surface machining technology	No. of takes – chips	Roughness after machining Ra [μm]	Cutting tool condition	Machining process with cooling	Thickness of final take	
						[mm]	[mm]
31 849.3 13	a–standard machining by turning b–grinding + turning	2	6.3–12.5 0.4	Blunt-used	NO	4	1.3
31 849.6 14	After turning strengthened by shot peening	3	3.2	New	YES	< 1	± 0.5

The fatigue tests were carried out on a Schenk machine which was able to induce a bending moment of 100 kNm. The stress amplitude was induced by an adjustable crank mechanism. The induced moment was measured with a force sensor. The tests were carried out in a mode of alternating flat bending at cycle asymmetry $R = -1$ and loading frequency 50 Hz. Fatigue strength was determined using a staircase method for 50% probability of the test bar failure, for number of cycles $N = 107$.

Results of the fatigue strength tests of the three surface machining variants are presented in Table 5. Visual inspection of the test bars after the fatigue strength test revealed that in majority of the bars, the fatigue failure was initiated on both sides of the surface, i.e. from the machined as well as the ground surface. However, there were cases when the failure was initiated either only on the machined or only on the ground side of the surface.

These results led us to believe that the fatigue strength of a wheel with its surface machined is not much lower than the fatigue strength of those wheels whose surface was ground. Therefore, setting more stringent requirements on machining operations by specifying smaller final takes or smaller cutting tool feeds will not in the end significantly increase the wheel's fatigue strength.

Table 5

**Resultant fatigue strengths of the test bodies obtained from flat bending for
the three machining variants**

Machining technology	Resultant fatigue strength [MPa]	Standard deviation [MPa]
Standard turning operation on a CNC dual-slide vertical lathe	268.33	9.47
Surface grinding	280.0	9.9
Shot peening of the surface before final mechanical turning	313.3	8.12

The positive effect of shot peening of the web surface manifested itself by an approximately 12% increase in the fatigue strength of the test samples. This effect can be explained not only by homogenisation of residual stresses and introduction of a compression stress component, but also by the final take during which a small tool feed was applied, with the final cut not exceeding 0.5 mm, ensuring that the strengthened sub-surface layer is not removed. Based on these results which confirmed the positive effect of surface shot peening, it was not at that stage clear which factor to what degree had an effect on the fatigue strength of those wheels which have been only machined, to the extent that some met the requirement of the standard with a sufficient spare strength capacity, while others failed prematurely.

It was only after we had analysed wheels which were machined on different types of vertical lathes that we realised the importance of this factor. A more or less identical machining technology was used on all these lathes. On some lathes, it was not possible to machine a wheel web to full satisfaction without the development of fissures. Vibrations of the lathe's slide with tool post was later identified as the main cause which, when machining a railway wheel web, leads to enormous differences in the fatigue strength of railway wheels which were machined in a standard way. When the slide rattled, fissures developed in the groove during the machining operation, which varied especially by their length. As is apparent from the Kitagawa diagrams, the longer the fissure, the lower the material's fatigue strength.

While the lathes on which, because of capacity issues, machined were wheels selected for fatigue strength tests which required two wheels of the given type, were of an older version and left fissures in the wheel web ranging in length from 150 μm to 600 μm , wheels for standard commercial contracts in batches counting hundreds of units, showed in later conducted analyses only fissures between 20 μm and 90 μm long.

An example of the differences in fatigue strength of railway wheels is presented in Table 6, in which in addition analysed on three wheels is also the effect of the cutting tool's sharpness. Therefore, an experiment was devised and conducted which studied the effect of using a new cutting tool blade, a blade which had already been used to machine four wheel surfaces or a completely blunt blade which under normal circumstances the machine operator would have to replace. Another wheel, although of a different shape, was used for comparison purposes and was machined on the above mentioned old vertical lathe.

Comparison of stress levels of wheels machined on two different machining centres

Vertical lathe type	No. of cycles at stress level 240 MPa [×106 cycles]	No. of cycles at stress level 300 MPa [×106 cycles]	No. of cycles at stress level 360 MPa [×106 cycles]	Maximum observed fissure length [μm]
Single-slide old lathe	2.8	–	–	480
Dual-slide lathe–new cutting tool	10	10	10	42
Dual-slide lathe–slightly used cutting tool	10	10	0.5	108
Dual-slide lathe–blunt cutting tool	10	10	4.3	136

As the results of the experiment clearly show, the type of lathe used to machine the wheels selected for fatigue strength tests matters a great deal, and to a lesser degree the cutting tool blade used is also important. If we want to achieve a high quality surface, it is necessary to use a new, as yet unused blade, although the resultant fatigue strength of a wheel machined with a completely blunt tool, which is 25% better than what is required by the standard, shows that from the point of view of the product safety as well as certainty of the test result's reliability, the outcome is quite adequate.

The experiments were then extended by mapping the effect of the type of lathe used for machining the wheels. Included were the lathes upon which about 95% of all wheels at BONATRANS GROUP a.s. are machined. The results were unexpectedly good, with an average fatigue strength of the products tested and machined on these lathes being around 300 MPa.

Based on this experience, all unsatisfactory single-slide vertical lathes were discarded from wheel machining operations. Now, the standard practice is that wheels for fatigue strength tests are taken from batches machined for a client. The results of tests of the last 50 wheels show that only one type of wheel failed to meet the requirements of the EN 13262 standard. In this wheel however, which did not meet the requirements of the standard, was found a 60 μm big silicate inclusion, situated on the wheel web's surface which, as the conducted analyses showed, was the cause of a fatigue failure after 3.8 million cycles at test stress level 240 MPa. The remaining 49 wheels met the requirements of the standard with flying colours, and those wheels used to continue with the test until a crack developed, mostly failed only at a stress level of 360 MPa.

To prevent the situation from repeating itself on a different type of a lathe, a document was drafted for the needs of the Quality Control Department personnel, titled 'Guidelines for checking surfaces of wheel webs designated for fatigue strength tests', which describe how the wheel web surface is to be checked, both by visual inspection of the wheel web, and with a portable video microscope which, due to its high depth of field, is even capable of detecting fissures in the wheel web's surface of a length below 150 μm.



Fig. 6. An optical video microscope used for detecting fissures in wheel webs

4. Techniques of increasing fatigue strength of railway wheels

For railway wheels, especially those destined for American markets, the requirement on increased fatigue strength of the wheel web is achieved by shot peening performed in accordance with standard AAR M107/M208, clause 7.0 [2]. The main advantages of wheels treated by shot peening are the considerably higher fatigue strength of the wheel web vis-à-vis the requirements of the EN 13262 standard, the introduction of compressive stresses into the wheel web and even distribution of residual stresses on the shot peened surface, and surface strengthening accompanied by demonstrable increase in the surface hardness.

The required effect is achieved by a stream of peening pellets blasted against a rotating solid railway wheel by two peening units. The velocity of the stream of peening pellets and their quantity can be continuously controlled by changing the speed (revolutions) of the peening unit's motors and the quantity of the supplied peening pellets. Solid railway wheels ready for shot peening must either have already been completely finally machined, or have their web finally machined and the wheel rim with tread and the hub faces roughly machined. When shot peening a wheel rim and a wheel hub which have been only rough-machined, these surfaces do not have to be covered, as final machining will be done only after the wheel web has been shot peened. Surfaces which are not to be shot peened and have already been finally machined, must be protected against the effects of shot peening by masking them. Only after they have been shot peened can the rough-machined parts be finally machined.

From the point of view of meeting standards and ensuring stable and reproducible results for all wheels after shot peening, it is necessary to regularly check all technological parameters, such as the size of the blasted medium (pellets), the blasting intensity and the extent to which the surface is covered by the peening medium.

Controlling the size of the blasted medium (pellets) is closely related to the impact energy of the blasted pellets, and hence also to the blasting intensity. Pellets of a minimum size SAE 550 must be used for shot peening, because the pellet sorter has a sieve of 1.4 mm meshing; it is best to use pellets of size SAE 660 and grade SAE J 827. The pellet sizes must be checked at least once per shift, when the pellet magazine is being topped up with new pellets.

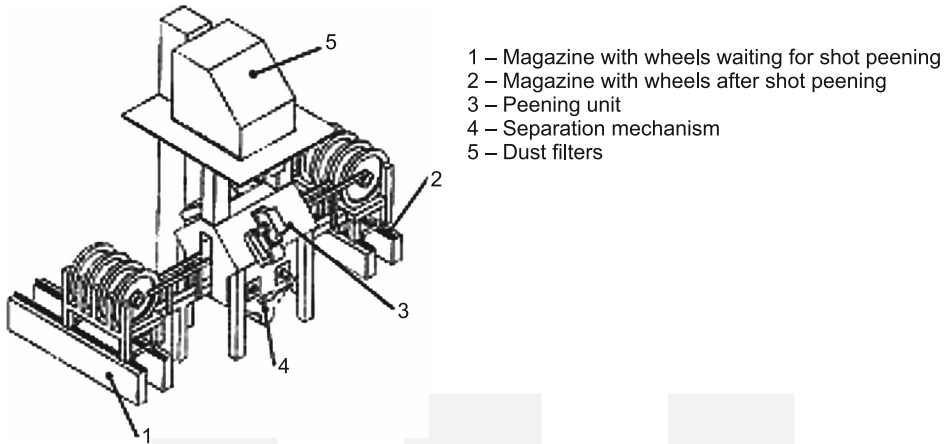

Fig. 7. A shot peening unit used to strengthen railway wheels

The blasting intensity must be sufficient to bend (sag) an ALMEN C test strip by at least 0.2 mm, and must cover 100% of the surface. At 100% coverage, the entire peened surface must be covered with mutually overlapping dents. Wheels are shot peened with an automatically selected cycle, and ALMEN C strips are measured in a special jig with a digital inclinometer. The sagging must be at least 0.2 mm but not more than 0.4 mm. A difference in the sagging of strips placed next to the wheel hub and next to the wheel rim should not be greater than 0.07 mm. The quality of coverage is checked on new, machined, as yet unshot peened wheels, at places where the strip holders are located.

The degree of surface coverage is assessed visually with a pocket microscope of $30\times$ magnification. The peening time is selected so that 100% of the surface is covered. The assessment can also be done using a special fluorescent dye or an alcohol marker. When using these methods, no traces of the marker or the fluorescent dye may remain on the surface.

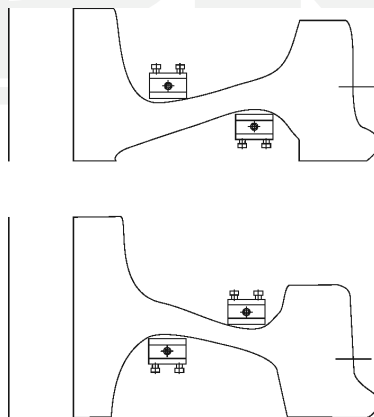

Fig. 8. Locations of ALMEN strips on the wheel web surface

In order for us to be able to qualify the effect of shot peening on the resultant fatigue strength of railway wheels on real scale, the following experiment was devised. The tests were carried out on wheel type 115.11 and 904.06. In total, four wheel variants were tested, namely a wheel with an unmachined web, a wheel with a machined web, a wheel with an unmachined but shot peened web, and a wheel with a machined and shot peened web.

The results of the tests for each of the above wheels with different machining technologies and shot peening are, for comparison purposes, presented in Fig. 9. All the tests were carried out on an Inova electro-hydraulic fatigue strength test machine at BONATRANS GROUP a.s.

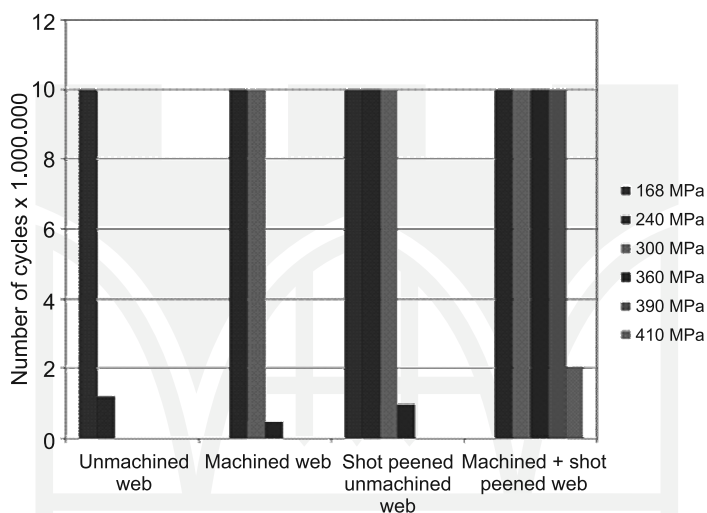

Fig. 9. Comparison of stress levels of railway wheels with different final finishing of the wheel web

As is apparent from Fig. 9, the wheel with unmachined web met the required fatigue strength of 168 MPa and failed only at radial stress level of 240 MPa. The wheel with a machined web failed only at the level of radial stress amplitude of 360 MPa.

In the wheel with the unmachined but shot peened web, the fatigue strength was increased by 78%, while for the one with the machined and shot peened web, the real increase amounted to only about 30%. The fatigue strength of the unmachined but shot peened wheel is comparable with the fatigue strength of the machined wheels.

The increase in the fatigue strength of the unmachined wheels can be explained by a decarbonised and oxidic surface layer, i.e. a poor quality surface which in addition, contains impressions whose origins can be traced to the process of forging the wheel, which can act as a stress concentrator. Shot peening, when applied to such a surface, strengthens this softer oxidised and decarbonised layer, and in addition, homogenises surface stresses and induces compression stresses which further increase the resultant fatigue strength.

5. Conclusion

The results obtained in the study of the fatigue strength of materials used in the production of railway wheelsets have led to the following conclusions:

1. When machining railway wheels, it is essential to set technology conditions in such a way that during machining, the cutting tool does not leave any minute fissures around 150 μm long, which would reduce the railway wheel's fatigue strength to such a degree that it would fail to meet the requirements of the EN 13262 standard on the fatigue life of railway wheel webs. The results obtained from the tests of railway wheels containing fissures have been confirmed by Kitagawa diagrams, which also contributed towards explaining the dramatic decrease in the fatigue strength of test samples containing cracks or fissures.
2. The fatigue strength of wheels manufactured by BONATRANS GROUP a.s. is around 300 MPa, which provides an adequate spare strength capacity when conducting fatigue strength tests at the stress amplitude level of 240 MPa required by the standard.
3. From the economy point of view, the best technique of how to increase the fatigue strength of wheel webs is to apply shot peening to the wheel's web, which is basically blasting the wheel web with steel pellets with a defined intensity determined by measuring the value of the sagging of an Almen strip, with the maximum possible coverage of the wheel web. Deploying this technique can increase the fatigue strength of machined wheels by as much as 30%, and in the case of unmachined wheels supplied with a rolled, unmachined web, by 78%.

This article has been elaborated in the framework of the project Opportunity for young researchers, reg. no. CZ.1.07/2.3.00/30.0016, supported by Operational Programme Education for Competitiveness and co-financed by the European Social Fund and the state budget of the Czech Republic.

References

- [1] ČSN EN 13262+A1, Railway applications–Wheelsets and bogies–Wheels–Product requirements, May 2009.
- [2] AAR M-107/M208, *AAR Manual of Standards and Recommended Practices*, Wheels and Axles, 2011.
- [3] Okagata Y, Kiriyaama K, Koat T., *Fatigue strength evaluation of the Japanese railway Wheel*, Fatigue Fact. Engng. Mater Struct 30, 356-371.
- [4] Strnadel B., *Material Science II, material degradation processes and design*, Mining Academy – Technical University of Ostrava, Ostrava 2008.
- [5] Moravec V., *Hardness and durability of dynamically loaded machine parts*, Mining Academy – Technical University of Ostrava, Ostrava 2007.
- [6] Klesnil M., Lukáš P., *Fatigue at metal materials*, Academia, Prague 1975, 222.
- [7] Beretta S., Carboni M., Lo Conte A., Regazzi D., Trasatti S., Rizzi M., *Crack Growth Studies in Railway Axles under Corrosion*.
- [8] Beretta S., Carboni M., Fiore G., Lo Conte A., *Corrosion–fatigue of AIN railway axle steel exposed to rainwater*, International Journal of Fatigue 32, 2010, 952–961.
- [9] Lukáš P., Kunz I., Weiss B., Stickler R., *Impact of short cracks and minor notches on fatigue strength*, Metal Materials 5, 26, Bratislava 1988.